

NOTES

MATERIAL: -DIECAST ALUMINUM ALLOY,
-Six 6-32 Phillips screws

VIEW OF BOX (LID REMOVED)

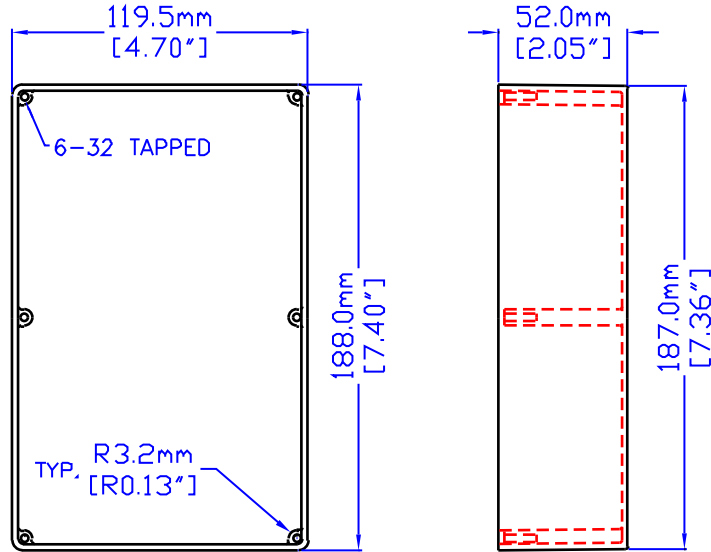

NOTE:
FOR DETAIL
DIMENSIONING
REFER TO DRAWING
1590D

VIEW INSIDE LID

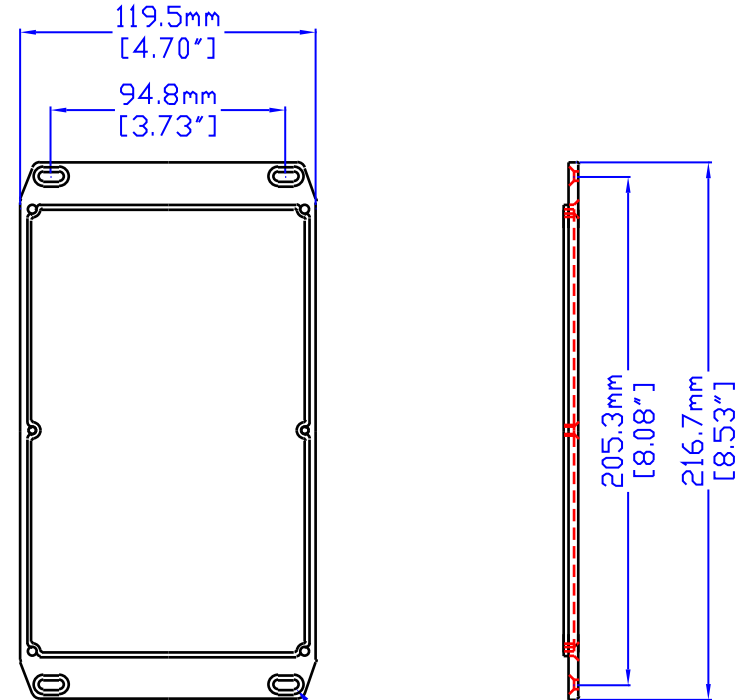

1590DFL

1590D WITH SPECIAL FLANGED LID,
AVAILABLE FROM STOCK.

WATERPROOFING KIT IS AVAILABLE
PART # 1590DG,
THE GASKET KIT WILL AFFORD PROTECTION
AGAINST LIQUID TO NEMA 4 AND IP65 LEVELS.

THIS ENCLOSURE IS ALSO AVAILABLE IN BLACK
AND GRAY TEXTURE FINISH.



HAMMOND MANUFACTURING

1590DFL

CANADA - PH (519) 886 7170 - FAX (519) 886 8311
U.S.A. - PH (716) 631 5700 - FAX (716) 631 1156