

PRODUCT NUMBER	CONTACT PLATING NOTE
10073379-001LF	NOTE 2

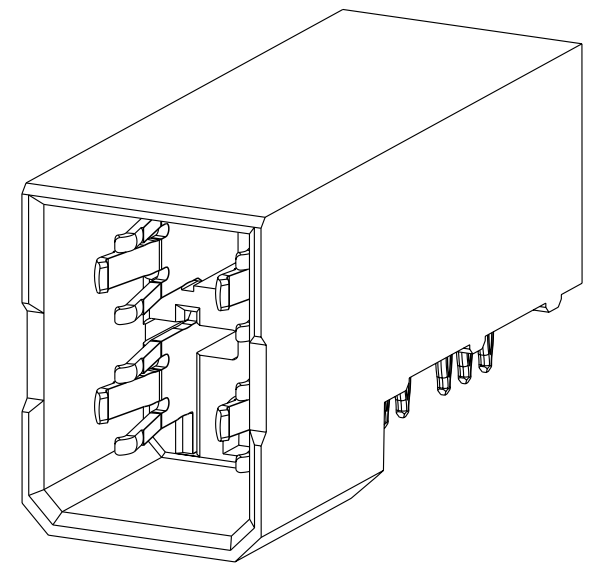

SCALE 3:1

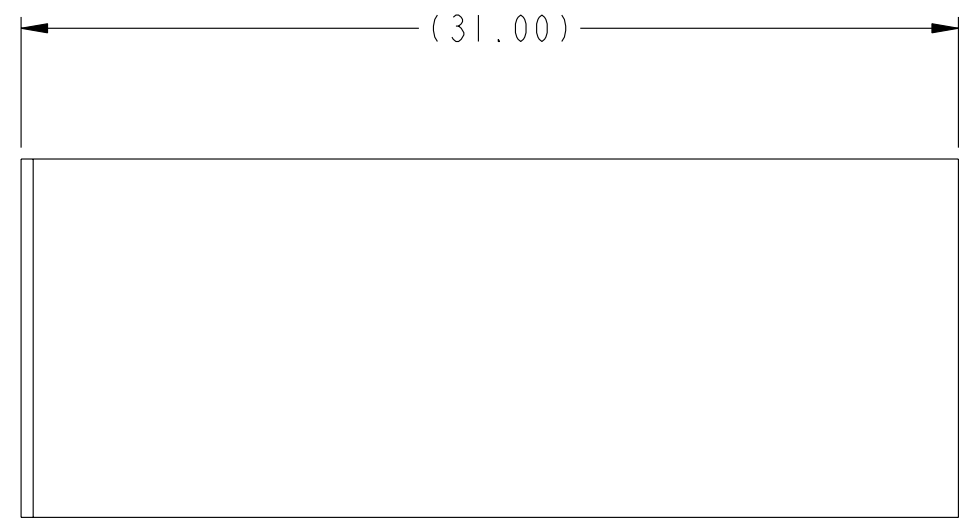
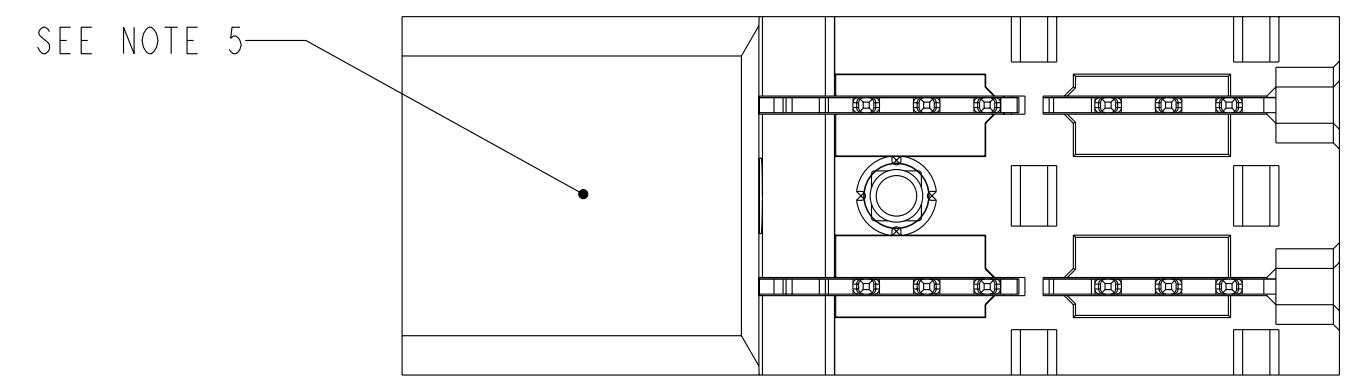
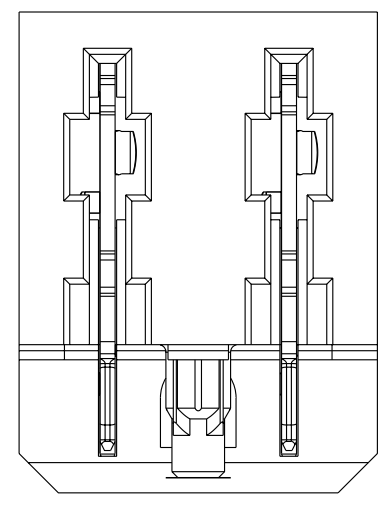
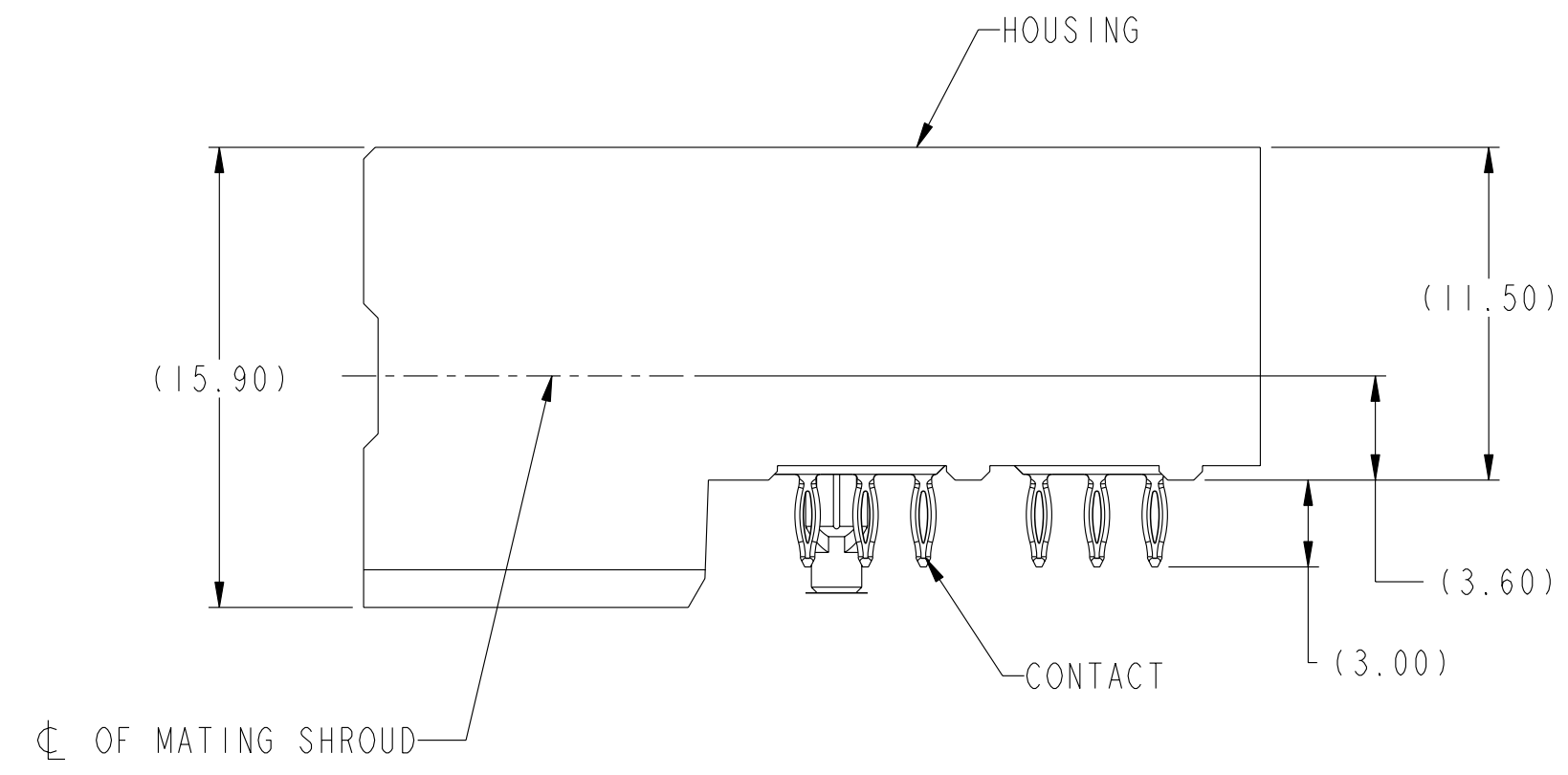
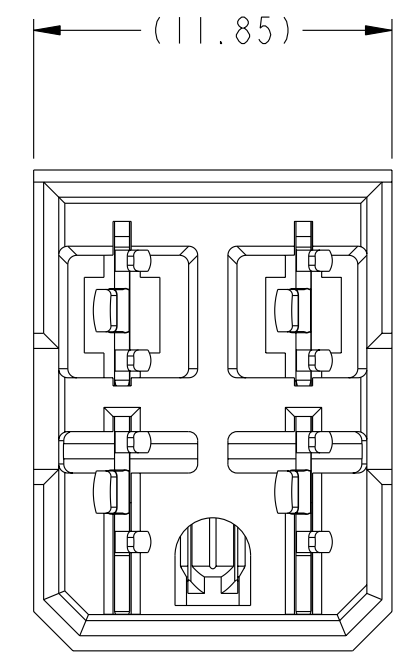

CONFIDENTIAL

www.fciconnect.com		surface ASME Y14.5	tolerance std ASME Y14.5	projection MM
		TOLERANCES UNLESS OTHERWISE SPECIFIED		
Dr	C. H. TAN	2006-10-18	ANGULAR	0.X ±
Eng	C. H. TAN	2006-10-18	LINEAR	0.XX ±
Chr	C. H. TAN	2007-09-17	0° ±°	0.XXX ±
Appr	JOEY NG	2007-09-17	Product family	2mm High Power
			size	A2
			Scale	4:1
			ECN	--
			Spec ref	GS-12-220
R/A HEADER ASSEMBLY, 2X2		catg no	10073379	
POWER, 11.5mm HEIGHT		customer	sheet 1 of 2	

rev	ecn no	dr	date
A	S07-0161	CH	2007-04-02
B	S07-0321	CH	2007-09-17
-	-	-	-
-	-	-	-
-	-	-	-
-	-	-	-

Copyright FCI.
FCI

TOP LAYER DESCRIPTION	TABLE I PLATED THROUGH-HOLE REQUIREMENTS							
	DRILLED HOLE DIAMETER	COPPER THICKNESS	TIN-LEAD THICKNESS	NICKEL THICKNESS	GOLD THICKNESS	TIN THICKNESS	SILVER THICKNESS	FINISHED HOLE DIAMETER
TIN-LEAD	0.81-0.86 (0.85 DRILL)	0.025 - 0.050	0.005 - 0.015	--	--	--	--	0.65 - 0.80
IMMERSION TIN	0.81-0.86 (0.85 DRILL)	0.025 - 0.050	--	--	--	0.9 - 1.5um	--	0.70 - 0.80
IMMERSION SILVER	0.81-0.86 (0.85 DRILL)	0.025 - 0.050	--	--	--	--	0.15 - 0.65um	0.70 - 0.80
COPPER (SEE NOTE 11)	0.81-0.86 (0.85 DRILL)	0.025 - 0.050	--	--	--	--	--	0.70 - 0.80
GOLD	0.81-0.86 (0.85 DRILL)	0.025 - 0.050	--	0.003 - 0.007	FLASH UP TO 0.0002	--	--	0.69 - 0.80

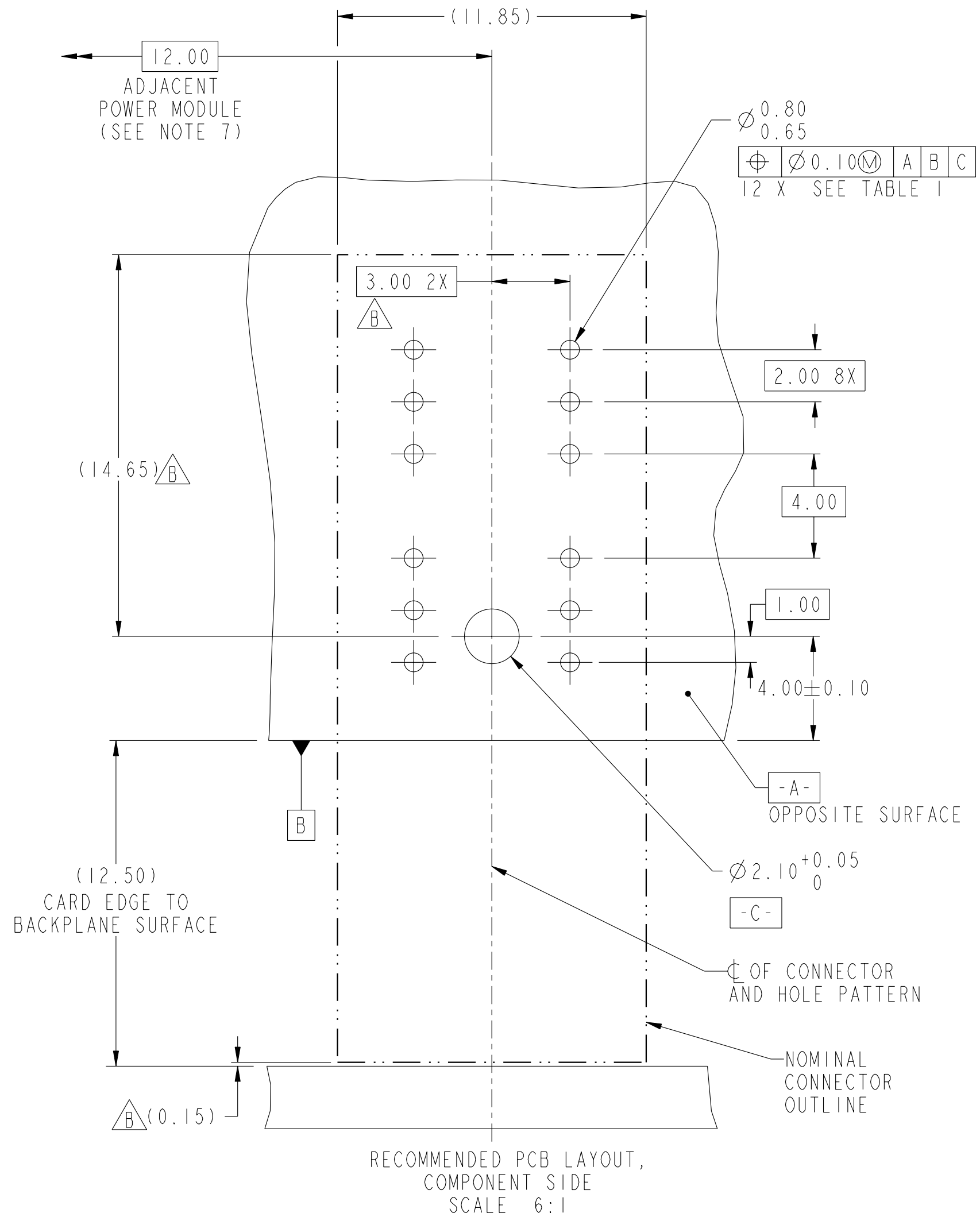

- NOTES:
- CONNECTOR MATERIALS:
HOUSING: HIGH TEMPERATURE THERMOPLASTIC, BLACK
UL 94V-0 COMPLIANT
CONTACT: HIGH PERFORMANCE COPPER ALLOY
 - CONTACT PLATING:
PRESS-FIT TAIL: 0.5um MIN MATT TIN OVER NICKEL.

SEPARABLE INTERFACE: PERFORMANCE-BASED PLATING, QUALIFIED TO MEET THE REQUIREMENT OF FCI PRODUCT SPECIFICATION GS-12-220, INCLUDING TELCORDIA GR-1217-CORE (NOVEMBER 1995) CENTRAL OFFICE
 - PRODUCT SPECIFICATION: GS-12-220
 - APPLICATION SPECIFICATION: GS-20-023
 - PRODUCT MARKING (PRODUCT NUMBER & LOT CODE) ON HOUSING.
 - MINIMUM NOMINAL PCB THICKNESS: 1.6mm
 - REFER TO CUSTOMER DRAWING 10035911 REGARDING INFORMATION REGARDING PCB LAYOUT OF POWER AND GUIDE MODULES RELATIVE TO SIGNAL MODULES.
 - PRODUCT MEETS EUROPEAN UNION DIRECTIVES AND OTHER COUNTRY REGULATIONS AS DESCRIBED IN FCI SPECIFICATION GS-22-008.
 - PACKAGING MEETS FCI SPECIFICATION GS-14-920.
 - HOUSING COMPONENT WILL WITHSTAND EXPOSURE TO 260°C PEAK TEMPERATURE FOR 60 SECONDS IN A CONVECTION, INFRA-RED, OR VAPOR PHASE REFLOW OVEN.
 - COPPER PLATING THICKNESS IN CENTER OF VIA-HOLE CAN BE NO MORE THAN 0.003 LESS THAN OTHER AREAS.
 - A Δ SYMBOL WILL BE NEXT TO ANY DIMENSION, VIEW, OR NOTE WHICH HAS BEEN MODIFIED WITH THE CURRENT DRAWING REVISION

FCI	TITLE	R/A HEADER ASSEMBLY, 2X2	dwg no	10073379	Rev.	B
	catalog no	POWER, 11.5mm HEIGHT				
CUSTOMER			sheet 2 of 2			