

REVISONS		DATE	DWN	APVD
P	LTB			
B		16NOV07	JR	TM

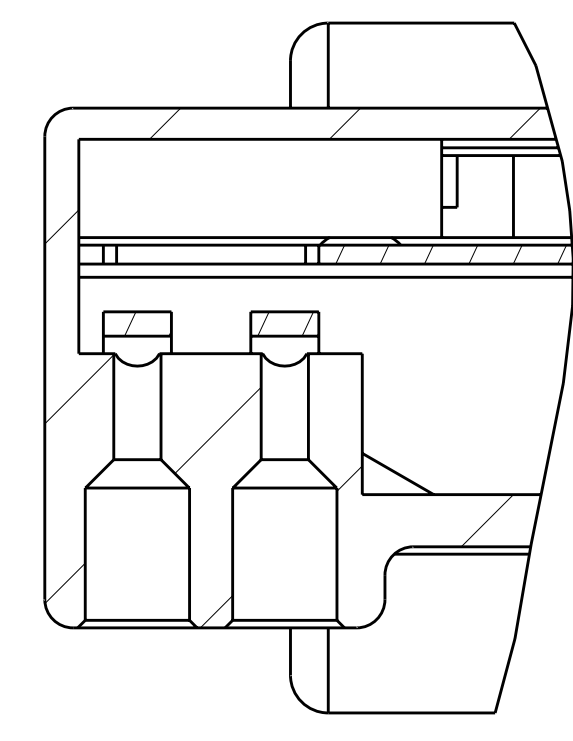

SECTION A-A

POKE-IN CAVITIES
 ACCEPTS 18 AWG PRE-STRIPPED
 SOLID WIRE
 STRIP LENGTHS: 9.53±0.8mm
 [3/8"±1/32"]

IDC AREA
 1811027-1 ACCEPTS 12 AWG SOLID OR STRANDED (19 STRANDS MAX), THHN WIRE
 1811027-2 ACCEPTS 18 AWG SOLID TFN/TEWN WIRE
 CONTINUOUS (FEEDTHRU) WIRE

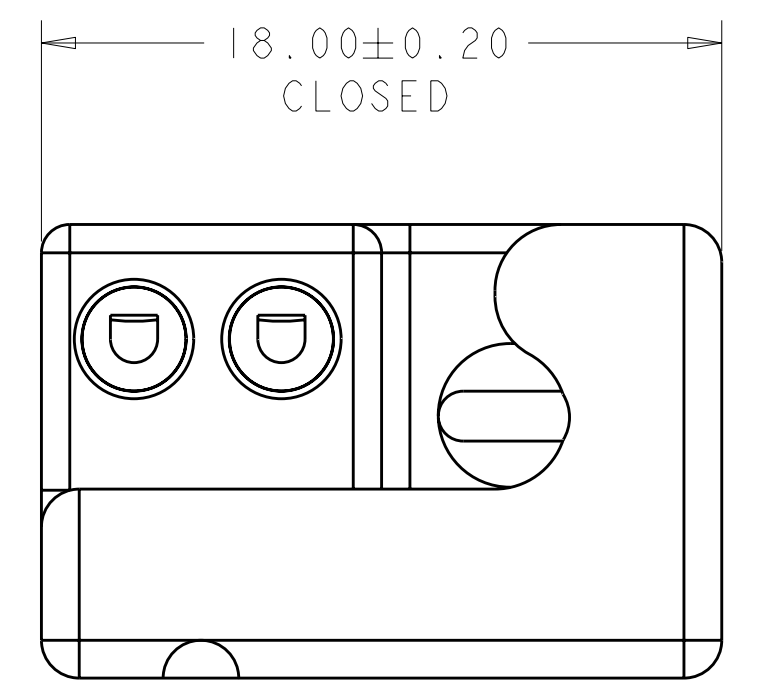
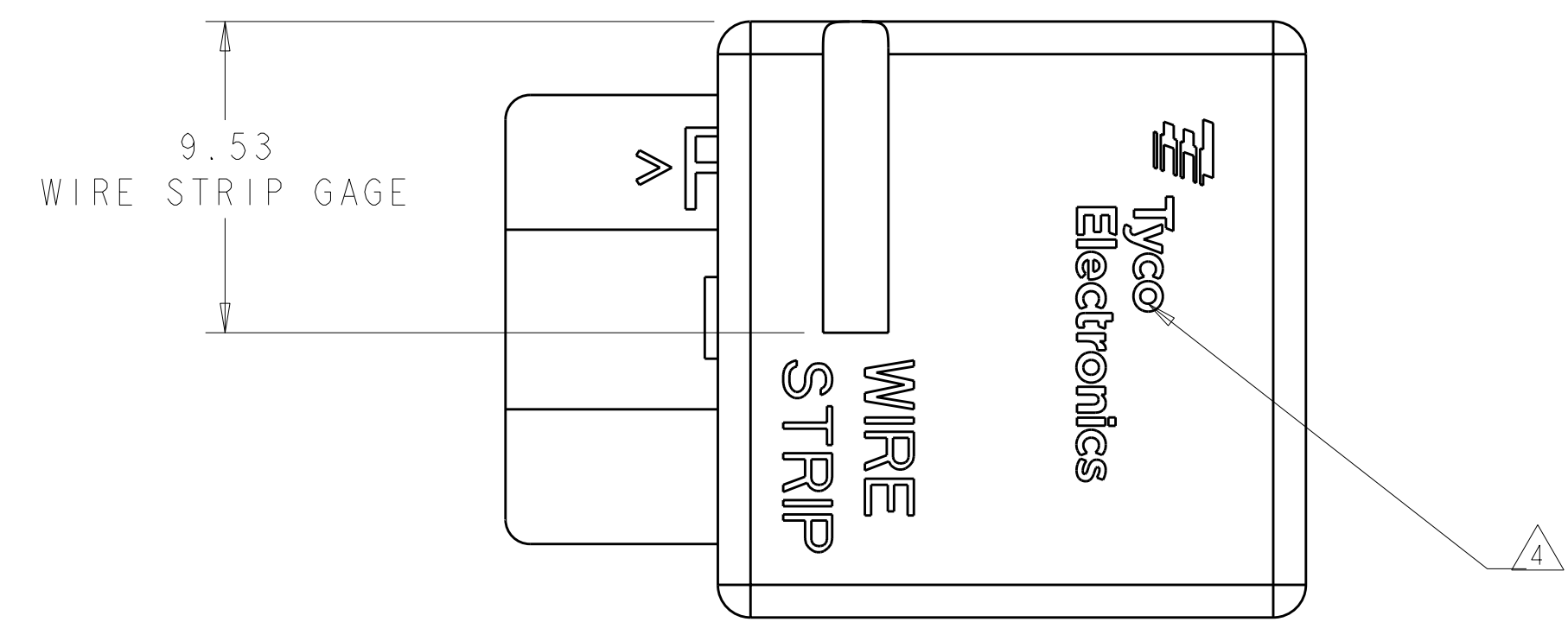
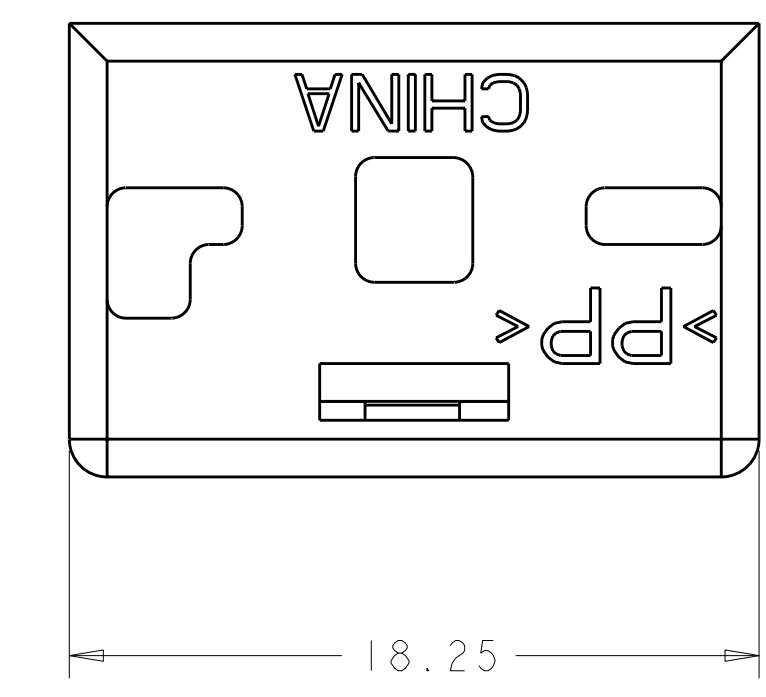
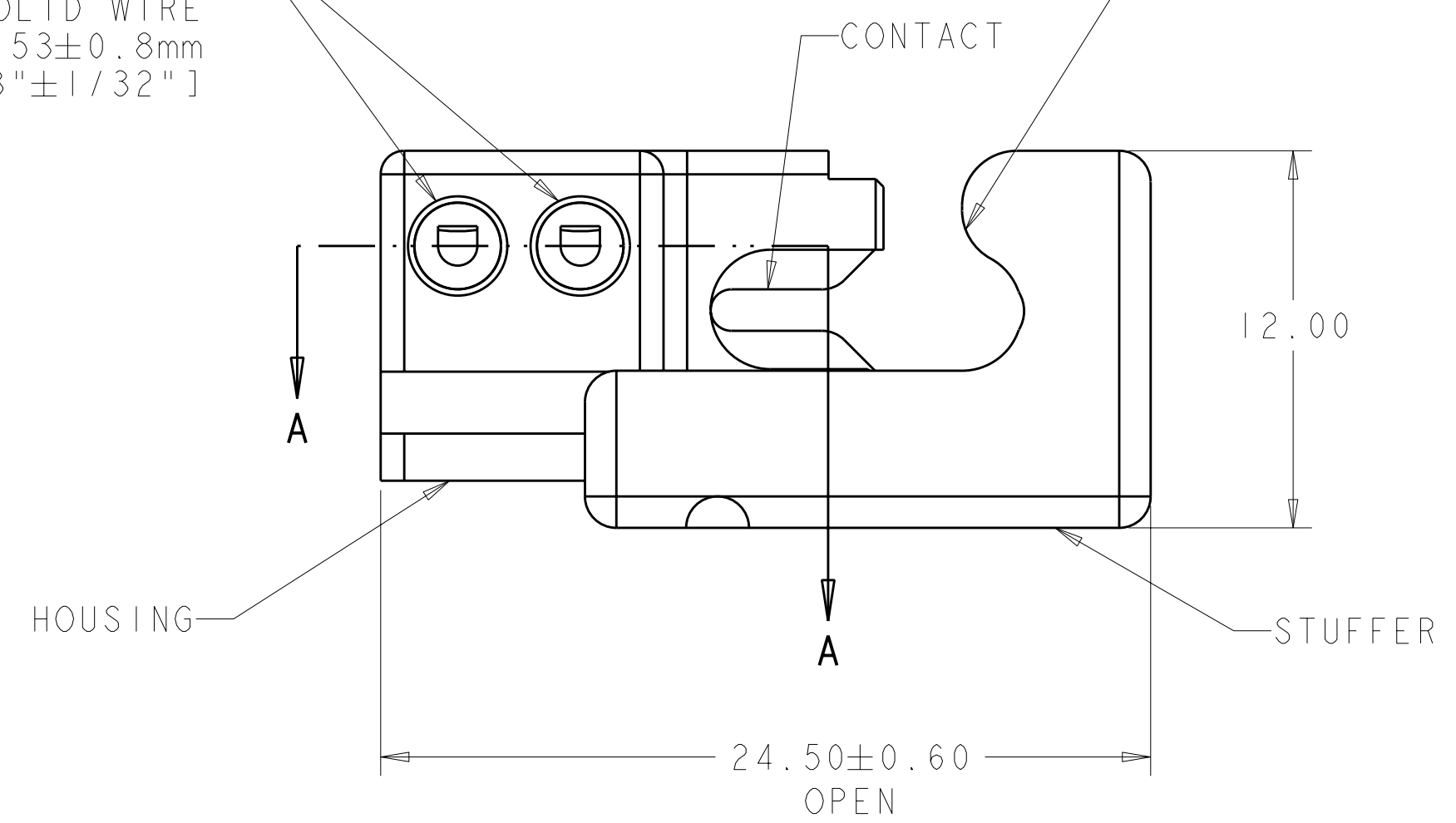
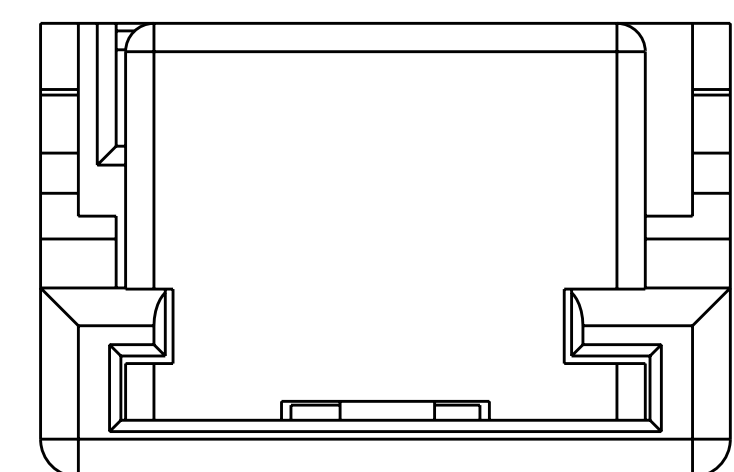

TERMINATED DETAIL

- △ MATERIAL:
 HOUSING: THERMOPLASTIC, COLOR: SEE TABLE
 STUFFER: THERMOPLASTIC, COLOR : SEE TABLE
 CONTACT: COPPER ALLOY, 0.50 THICK
- △ FINISH:
 CONTACT: TIN PLATE
- 3. PRODUCT SPECIFICATION: 108-2219
 APPLICATION SPECIFICATION: 114-13151
- △ THE LOGO MAY BE JUST "TYCO" UNTIL COMPONENTS
 ARE CONVERTED.

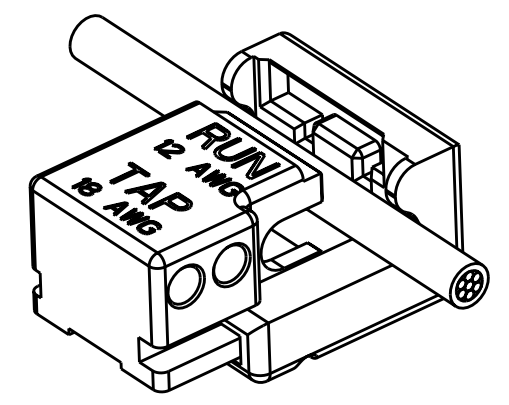

SCALE 2:1

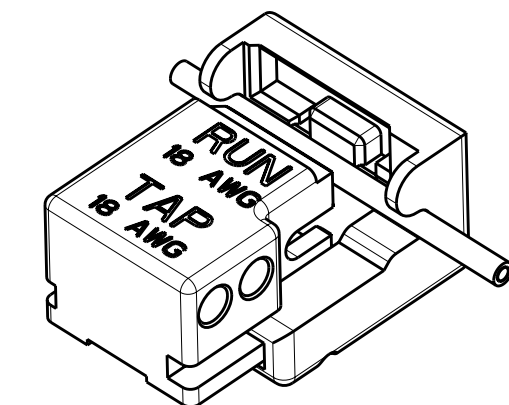

SCALE 2:1

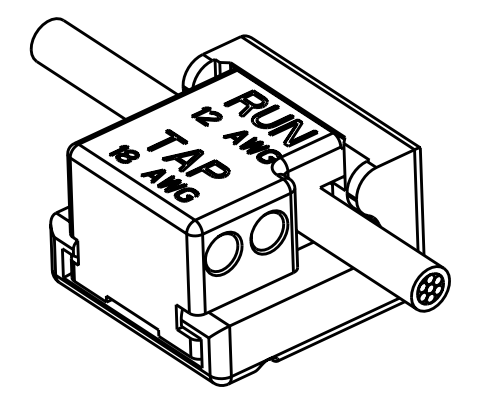

SCALE 2:1

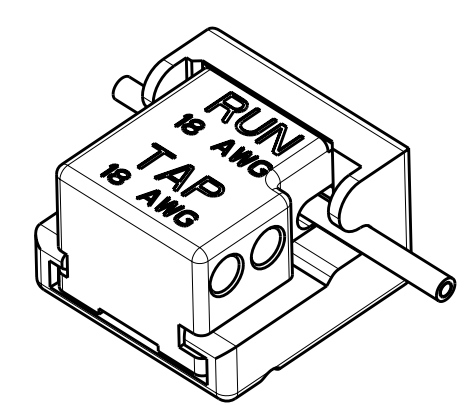

SCALE 2:1

1811027-1

1811027-2

BLUE	18 AWG	1811027-2
BROWN	12 AWG	1811027-1
CONNECTOR COLOR	FEED THRU WIRE SIZE	PART NUMBER

DIMENSIONS: mm 		TOLERANCES UNLESS OTHERWISE SPECIFIED: 9 PLC ± 1 PLC ±0.13 5 PLC ±0.013 4 PLC ± ANGLES ±#1		DWN D. FABIAN 28-Oct-04 CHK J. ALLISON 16-Nov-07 APVD J. ALLISON 16-Nov-07 NAME PRODUCT SPEC 108-2219 APPLICATION SPEC 114-13151 WEIGHT CUSTOMER DRAWING		Tyco Electronics Harrisburg, PA 17105-3608 ASSEMBLY, WIRE SPLICE IDC / POKE-IN SIZE CAGE CODE DRAWING NO A1100779C=1811027 SCALE 5:1 SHEET 1 OF 1 REV B	
-----------------------	--	--	--	---	--	---	--