

Customer Information Sheet

DRAWING No.: M50-311XX42

SHEET 2 OF 2

IF IN DOUBT - ASK

©

NOT TO SCALE

THIRD ANGLE PROJECTION

ALL DIMENSIONS IN mm

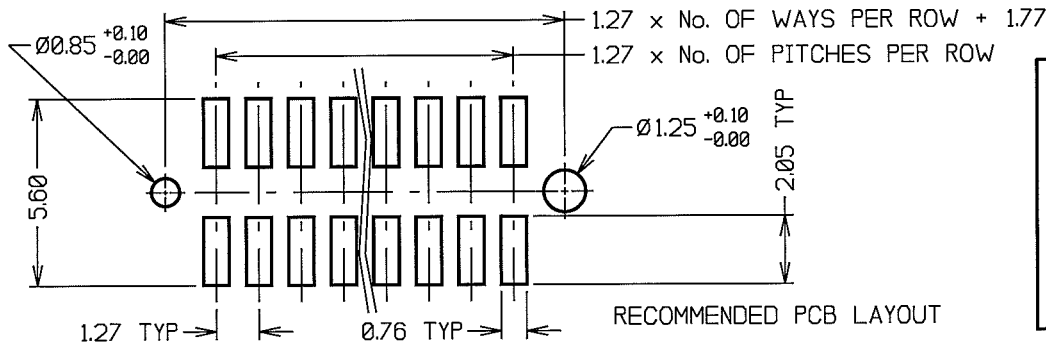
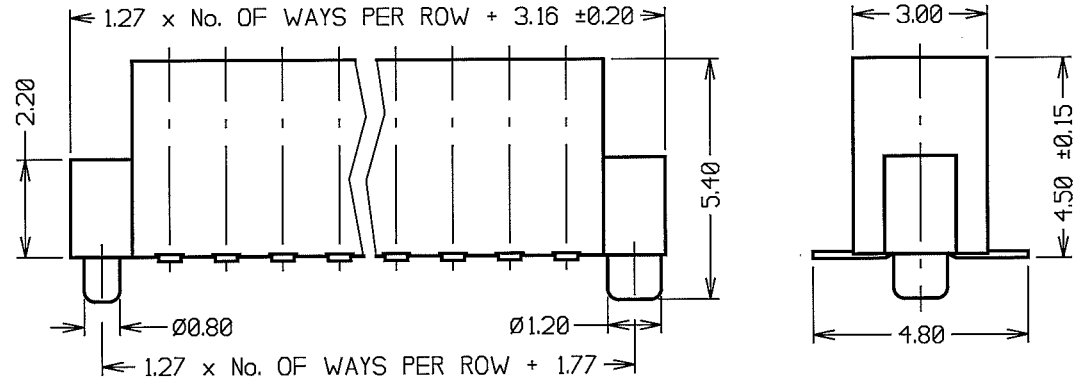
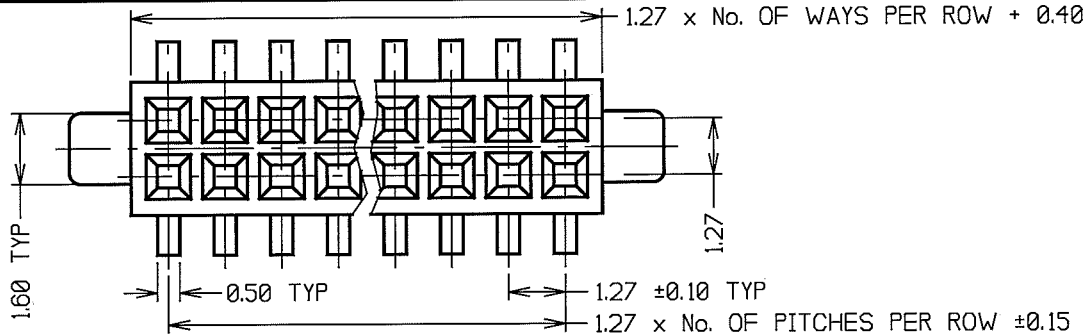

RECOMMENDED PCB LAYOUT

SPECIFICATIONS:

MATERIAL:
 MOULDING - HIGH TEMP THERMOPLASTIC UL94V-0
 CONTACTS - HIGH STRENGTH COPPER ALLOY
FINISH:
 CONTACT = 0.02-0.08µ GOLD ON CONTACT AREA,
 2.5-3.8µ 100% TIN ON TAILS

ELECTRICAL:
 CURRENT RATING = (ALL CONTACTS ARE
 ELECTRICALLY LOADED) - 1 AMP
 CONTACT RESISTANCE = 30 MILLIOHMS MAX
 INSULATION RESISTANCE = 1000 MEGOHMS MIN
 DIELECTRIC WITHSTANDING = 250V AC MIN

MECHANICAL:
 CONTACT RETENTION = 3.0N NOMINAL
 INSERTION FORCE = 0.56N NOMINAL
 WITHDRAWAL FORCE = 0.15N MIN
 SOLDERABILITY = 260°C FOR 3 SECONDS
 DURABILITY = 600 CYCLES

ENVIRONMENTAL:
 TEMPERATURE RANGE = -40°C TO +105°C

PACKING:
 TUBE

FOR COMPLETE SPECIFICATION, SEE COMPONENT
 SPECIFICATION C029XX (LATEST ISSUE).

NOTES:

- ALL TOLERANCES ARE ±0.25 UNLESS OTHERWISE STATED.

ORDER CODE:

M50-311XX42

No. OF WAYS PER ROW
 05 TO 12, 15, 20, 25
 30, 35, 40, 45 & 50

FINISH:
 42 = SELECTIVE GOLD/100% TIN

RA	6	13.10.08	10175
NAME	ISS.	DATE	C/NOTE
APPROVED: <i>[Signature]</i>			
CHECKED: <i>[Signature]</i>			
DRAWN:		J. KEIR	
CUSTOMER REF.:			
ASSEMBLY DRG:			

HARWIN

HARWIN USA
 TEL: 603 893 5376
 FAX: 603 893 5396
 mis@harwin.com

HARWIN Europe (UK)
 TEL: 023 9231 4545
 FAX: 023 9231 4590
 mis@harwin.co.uk

HARWIN Asia
 TEL: +65 6 779 4909
 FAX: +65 6 779 3868
 mis@harwin.com.sg

THIS DRAWING AND ANY
 INFORMATION OR DESCRIPTIVE
 MATTER SET OUT HEREON ARE
 CONFIDENTIAL AND COPYRIGHT
 PROPERTY OF THE HARWIN
 GROUP AND MUST NOT BE
 DISCLOSED, LOANED, COPIED
 OR USED FOR MANUFACTURING,
 TENDERING OR FOR ANY
 OTHER PURPOSE WITHOUT
 THEIR WRITTEN PERMISSION.

TOLERANCES
 X. - ±1mm
 X.X - ±0.25mm
 X.XX - ±0.10mm
 X.XXX - ±0.01mm
 ANGLES = ±5°
 UNLESS STATED

MATERIAL:
 SEE ABOVE
FINISH:
 SEE ABOVE
S/AREA: mm²

TITLE:
 1.27mm PITCH DIL SMT VERT.
 SOCKET ASSEMBLY WITH POSTS
DRAWING NUMBER:
M50-311XX42