

Specifications

Material

Insulator: LCP, UL 94V-0, Black
 Contact: Copper Alloy
 Shell: Stainless Steel
 Latch: Stainless Steel
 EMI Spring: Stainless Steel

Plating

Contact

Contact Area: 3u" Au over Nickel
 Solder Tails: Matte Tin over Nickel
 Shell: Nickel
 Latch & EMI Spring: Cleaning

Electrical

Current Rating: 5.00A collectively for Vbus pins
 6.25A collectively for GND pins
 1.25A for B5 pin
 0.25A per pin for all other pins
 Voltage Rating: 20V DC
 Contact Resistance: 40mΩ max initial.
 50mΩ max after test
 Dielectric Withstanding Voltage: 100V AC
 Insulation Resistance 100MΩ min

Mechanical & Environmental

Operating Temperature: -30°C to +85°C
 Mating Force: 5 to 20 N.
 Unmated Force: 6 to 20 N after test
 Durability: 10,000 cycles

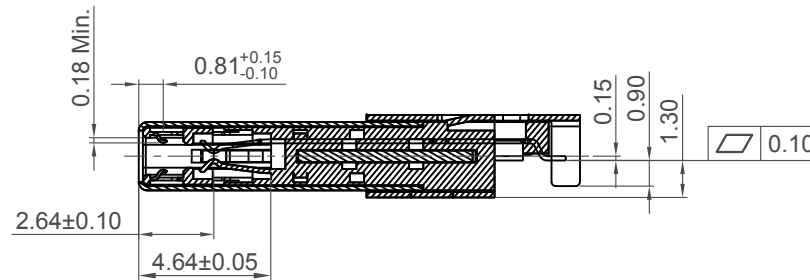
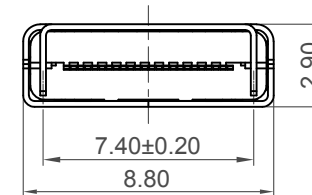
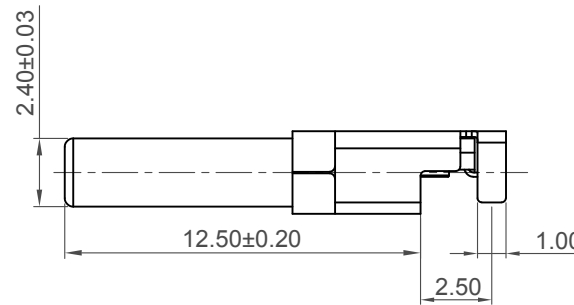
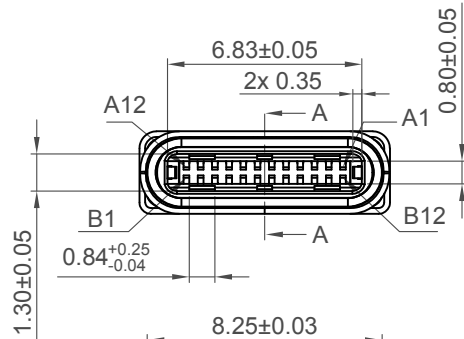

Section A-A

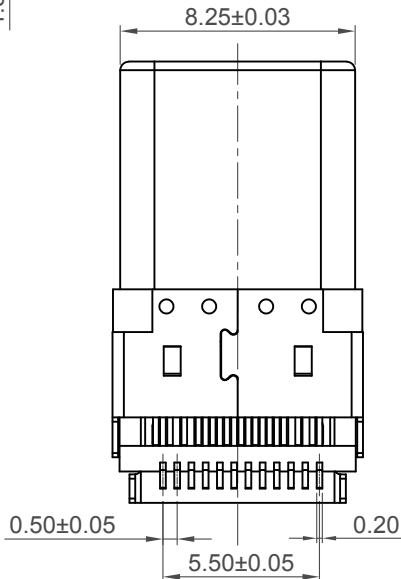

Ordering Grid

USB4155 = **03** = **C** Request Samples and Quotation

Contact Plating **Packing Options**
 03 = 3u" Gold C = Tape & Reel with Cap (1000 per reel)

Part Number		Product Description	
USB4155		USB3.1 Type C Plug, Horizontal, SMT	
Drawing Date		12th April 2021	
By	CC	Tolerances (Except as Noted)	Units:
Detail	Drawing Release	Length	Metric (mm)
Revision	A	X.X ± 0.30	
Date	12/04/21	X.XX ± 0.25	
		X.XXX ± 0.10	

This drawing is confidential and copyright of Global Connector Technology, Ltd (GCT). This drawing must not be copied or disclosed without written consent. E & OE

GCT
www.gct.co

Not to Scale Drawn By CC Sheet No. 1/4

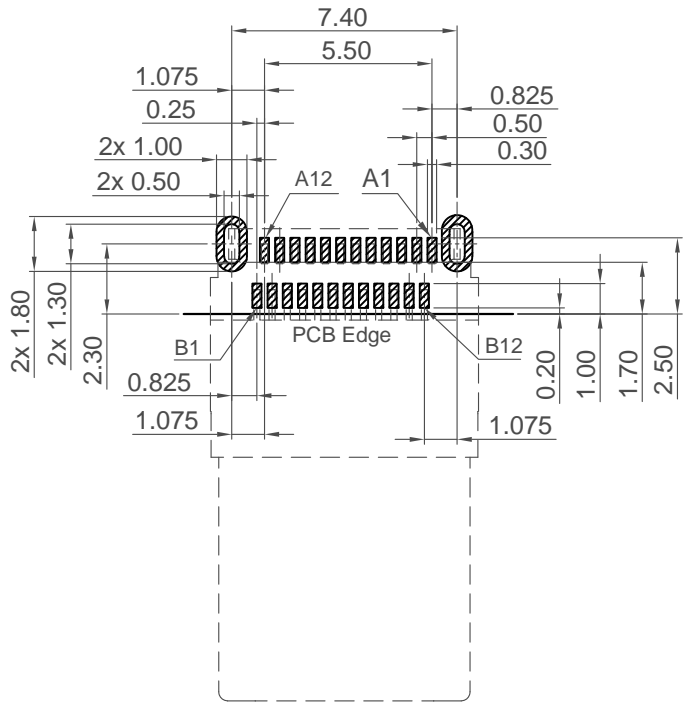

Recommended PCB Layout

Thickness 0.8 to 1.0 mm

Tolerance: $\pm 0.05\text{mm}$

▨ Solder Area □ Component Outline

Pin	Signal	Description
A1	GND	Ground return
A2	SSTXp1	Positive half of first SuperSpeed TX differential pair
A3	SSTXn1	Negative half of first SuperSpeed TX differential pair
A4	Vbus	Bus Power
A5	CC1	Configuration Channel
A6	Dp1	Positive half of the USB 2.0 differential pair - Position 1
A7	Dn1	Negative half of the USB 2.0 differential pair - Position 1
A8	SBU1	Sideband Use (SBU)
A9	Vbus	Bus Power
A10	SSRXn2	Negative half of second SuperSpeed RX differential pair
A11	SSRXp2	Positive half of second SuperSpeed RX differential pair
A12	GND	Ground return
SHELL		GND

Pin	Signal	Description
B12	GND	Ground return
B11	SSRXp1	Positive half of first SuperSpeed RX differential pair
B10	SSRXn1	Negative half of first SuperSpeed RX differential pair
B9	Vbus	Bus Power
B8	SBU2	Sideband Use (SBU)
B7	Dn2	Positive half of the USB 2.0 differential pair - Position 2
B6	Dp2	Negative half of the USB 2.0 differential pair - Position 2
B5	CC2	Configuration Channel
B4	Vbus	Bus Power
B3	SSTXn2	Negative half of second SuperSpeed TX differential pair
B2	SSTXp2	Positive half of second SuperSpeed TX differential pair
B1	GND	Ground return
SHELL		GND

USB4115 (Receptacle)

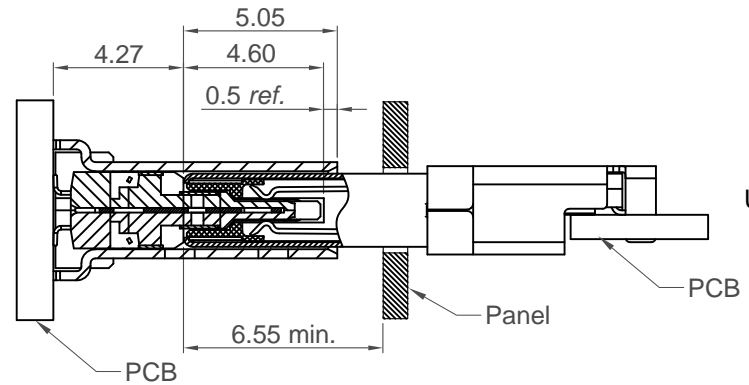

Plug and Receptacle Mating View

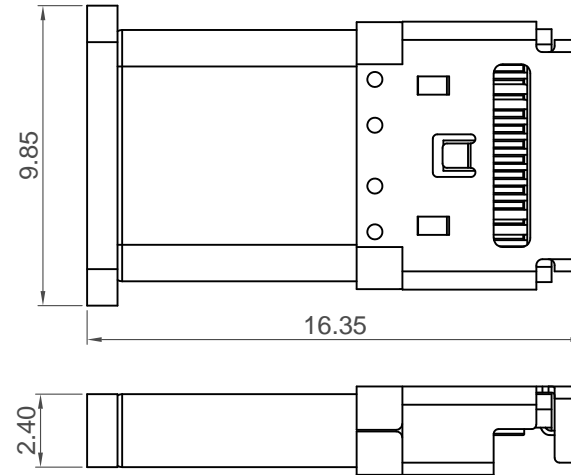
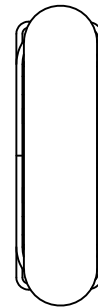

Cap Information

Part Number		Product Description	
USB4155		USB3.1 Type C Plug, Horizontal, SMT	
Drawing Date		12th April 2021	
By	CC	Tolerances (Except as Noted)	Units:
Detail	Drawing Release	Length	Metric (mm)
Revision	A	X.X ± 0.30	
Date	12/04/21	X.XX ± 0.25	
		X.XXX ± 0.10	

This drawing is confidential and copyright of Global Connector Technology, Ltd (GCT). This drawing must not be copied or disclosed without written consent. E & OE



Not to Scale	Drawn By CC	Sheet No. 2/4
--------------	-------------	---------------

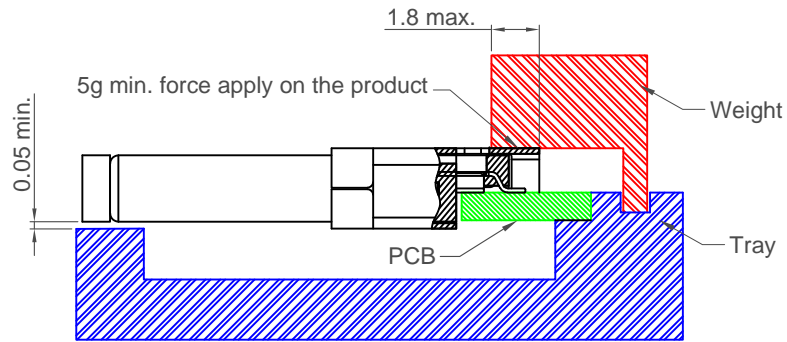

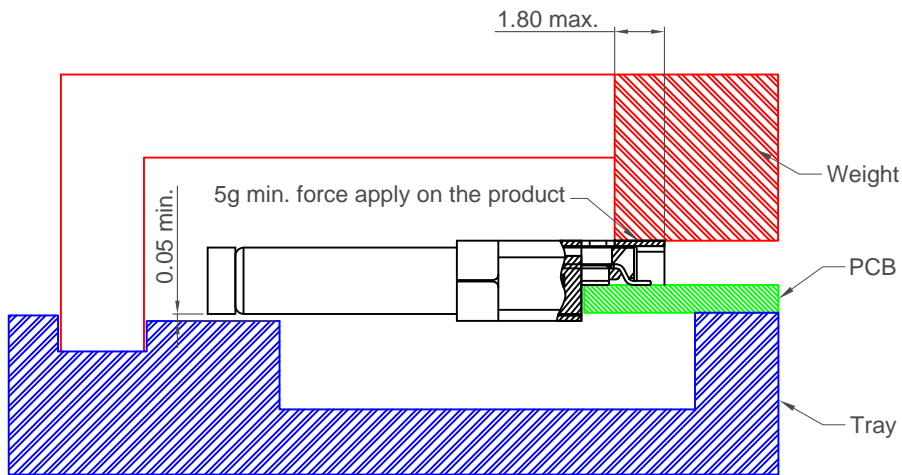
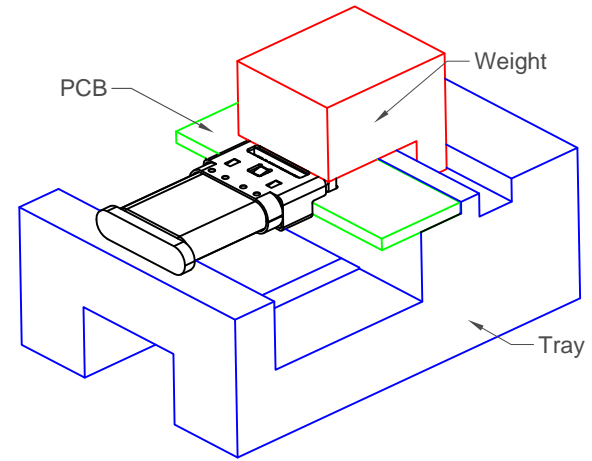

Proposal 1: Recommended Jig(Tray, Weight) be used in IR Reflow Process

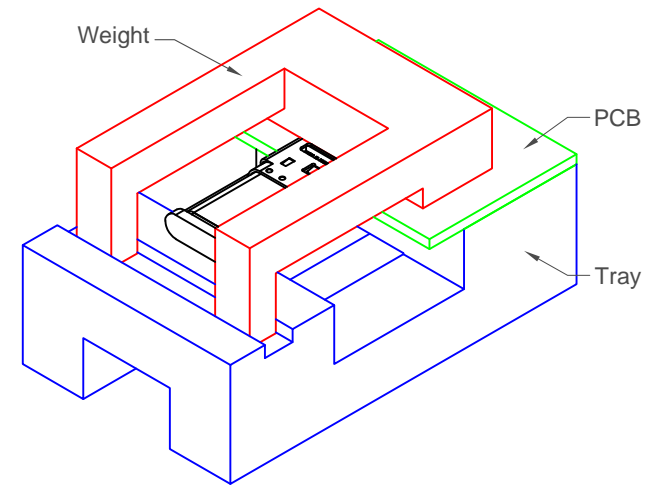

Proposal 2: Recommended Jig(Tray, Weight) be used in IR Reflow Process



Part Number		Product Description		GCT www.gct.co
USB4155		USB3.1 Type C Plug, Horizontal, SMT		
Drawing Date		12th April 2021		
By	CC	Tolerances (Except as Noted)	Units:	  <small>This drawing is confidential and copyright of Global Connector Technology, Ltd (GCT). This drawing must not be copied or disclosed without written consent. E & OE</small>
Detail	Drawing Release	Length	Metric (mm)	
Revision	A	X.X ± 0.30	 <small>3rd Angle Projection</small>	
Date	12/04/21	X.XX ± 0.25		
		X.XXX ± 0.10		
Not to Scale	Drawn By	CC	Sheet No.	3/4

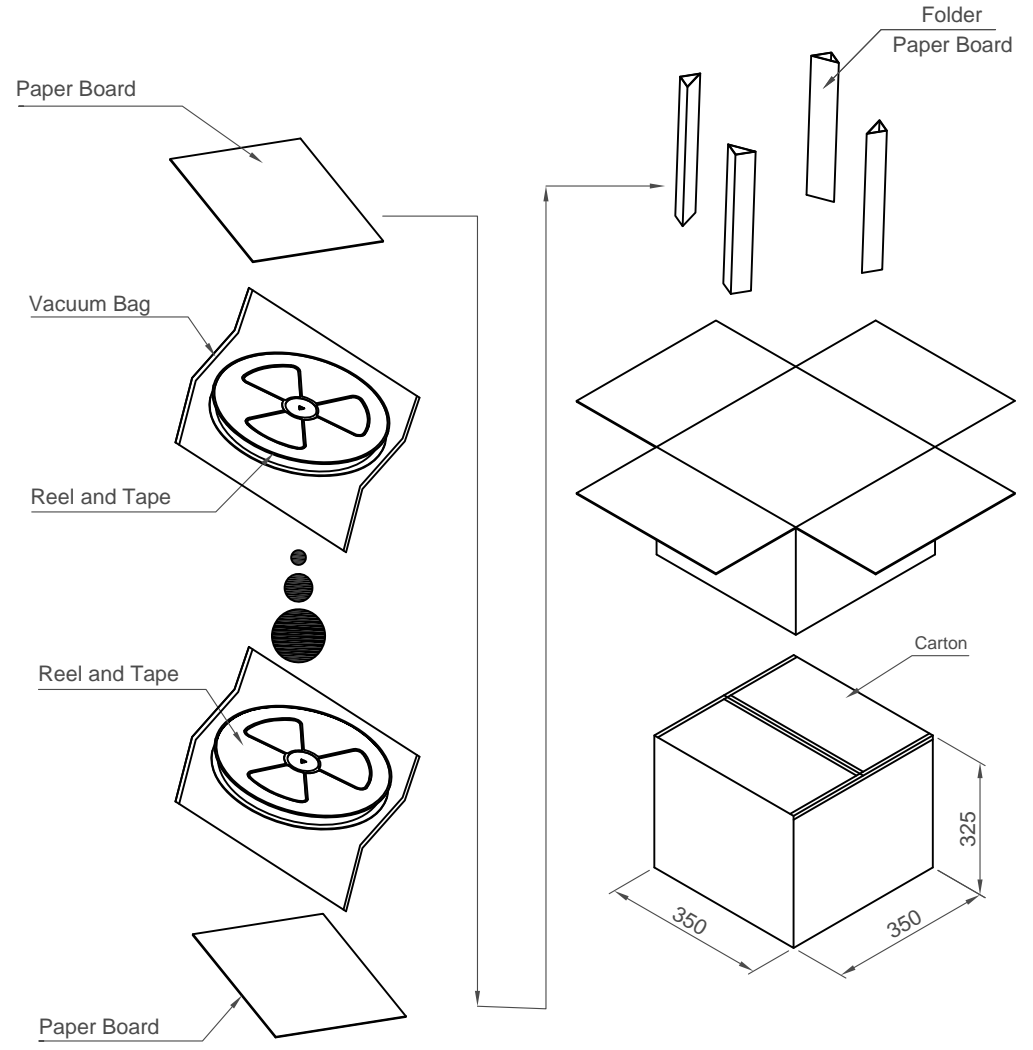
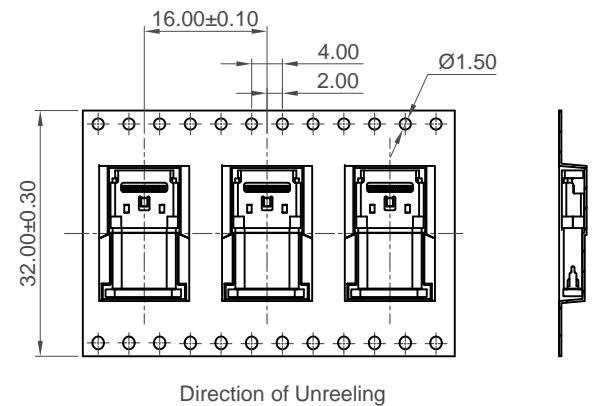
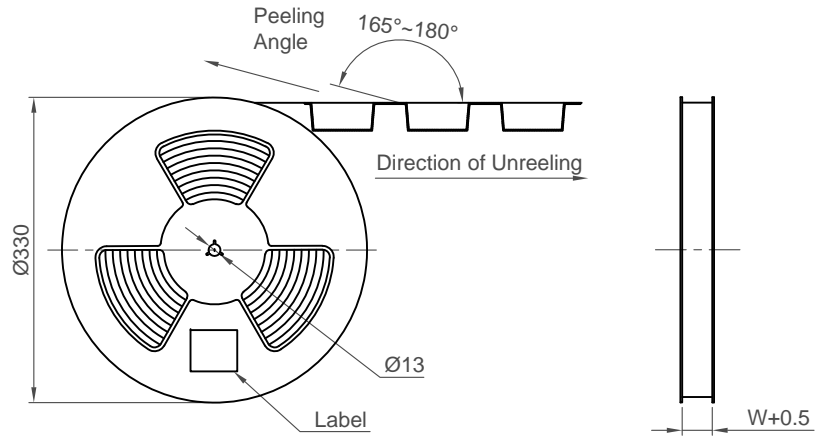
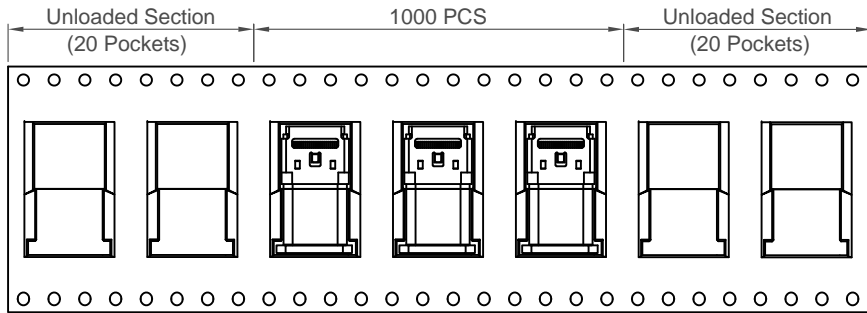

Pcs / Reel	Reels / Carton	Total Quantity
1000	6	6,000 pcs

Part Number		Product Description	
USB4155		USB3.1 Type C Plug, Horizontal, SMT	
Drawing Date		12th April 2021	
By	CC	Tolerances (Except as Noted)	Units:
Detail	Drawing Release	Length	Metric (mm)
Revision	A	X.X ± 0.30	
Date	12/04/21	X.XX ± 0.25	
		X.XXX ± 0.10	

© This drawing is confidential and copyright of Global Connector Technology, Ltd (GCT). This drawing must not be copied or disclosed without written consent. E & OE

Not to Scale Drawn By CC Sheet No. 4/4