

Customer Information Sheet

DRAWING No.: S1961-46R

IF IN DOUBT - ASK

©

NOT TO SCALE

THIRD ANGLE PROJECTION

ALL DIMENSIONS IN mm

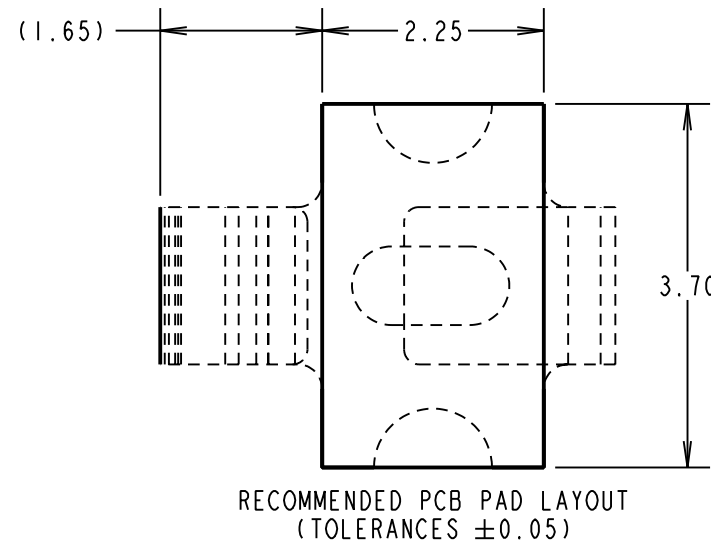

- NOTES:
 1. QUANTITY OF COMPONENTS PER REEL = 1200.
 2. THIS PRODUCT IS TAPED AND REELED IN ACCORDANCE WITH EIA-481 (ELECTRONICS INDUSTRIES ASSOCIATION).

SECTION X-X

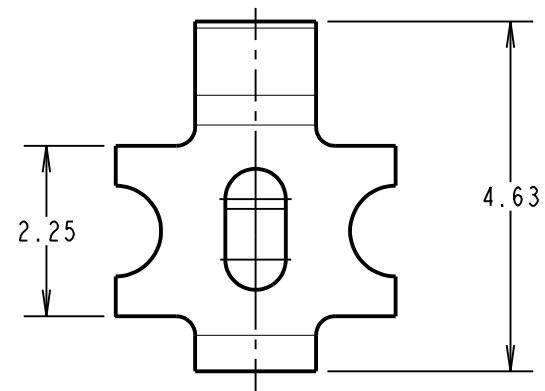
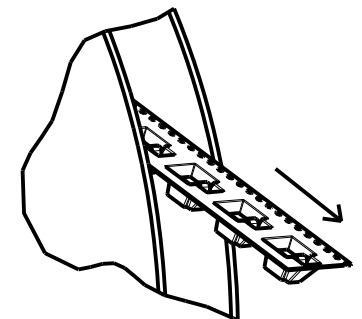
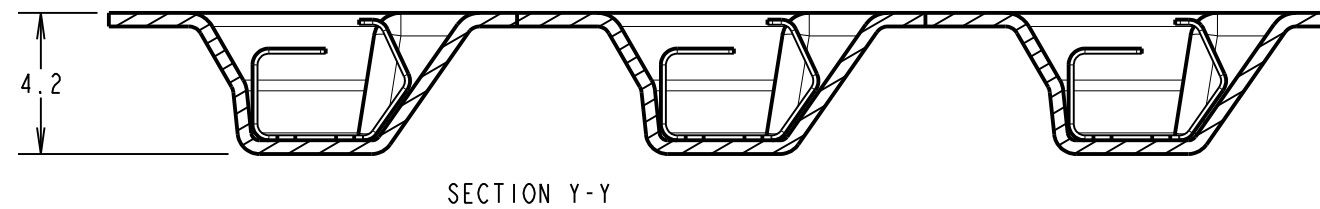
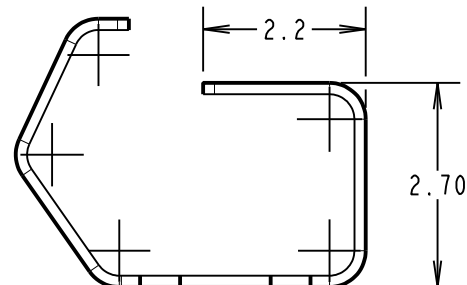
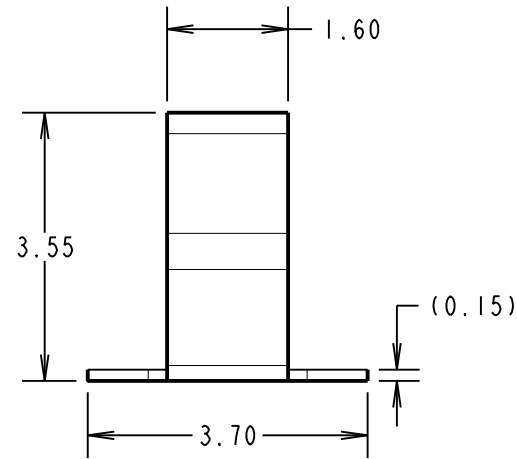
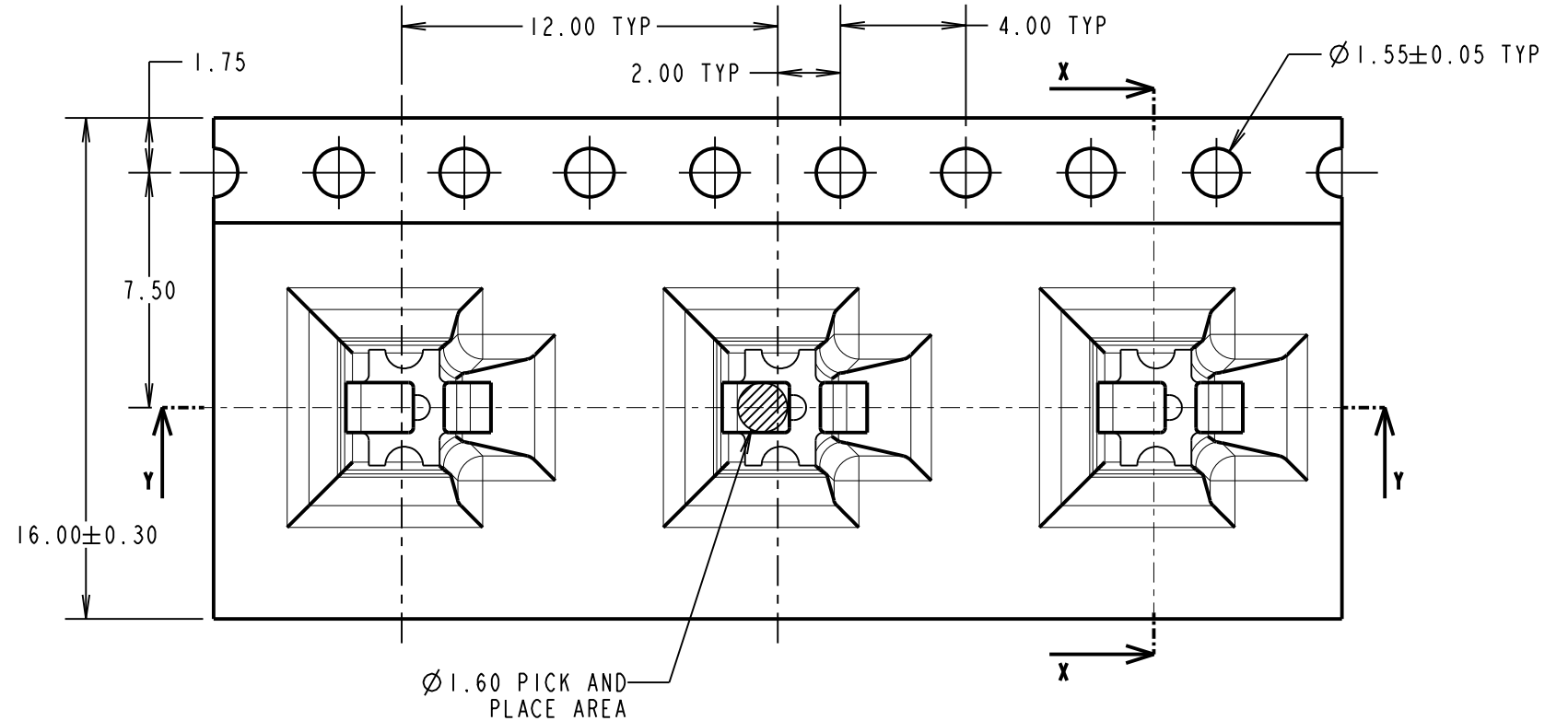
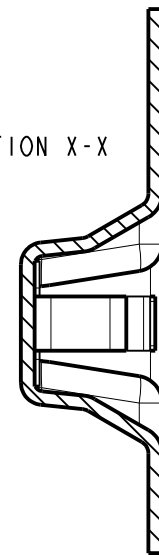

COMPONENT DETAILS

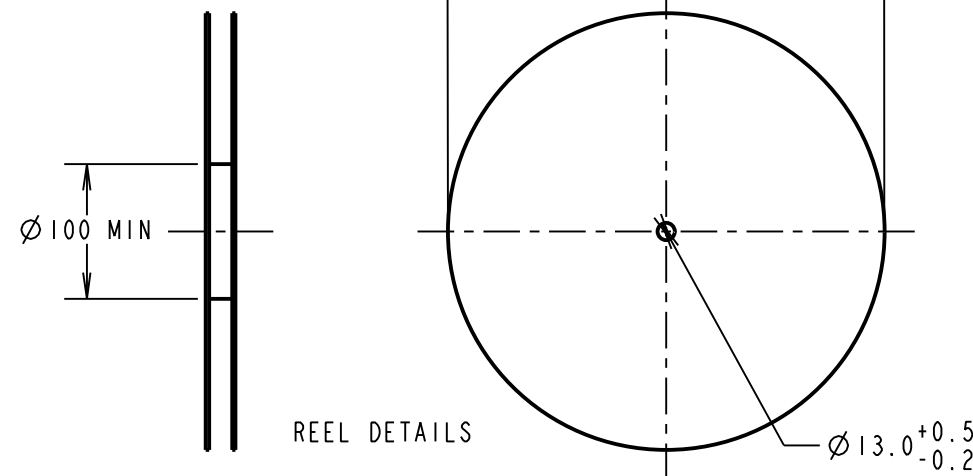
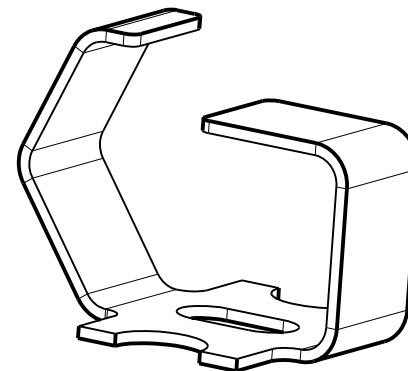

RTP	1	20.04.21	30447
NAME	ISS.	DATE	CN/CO
APPROVED: S.BENNETT			
CHECKED: R.ALEXANDER			
DRAWN: R.PORTLOCK			
CUSTOMER REF.:			
ASSEMBLY DRG:			

HARWIN

www.harwin.com
technical@harwin.com

THIS DRAWING AND ANY INFORMATION OR DESCRIPTIVE MATTER SET OUT HEREON ARE CONFIDENTIAL AND COPYRIGHT PROPERTY OF THE HARWIN GROUP AND MUST NOT BE DISCLOSED, LOANED, COPIED OR USED FOR MANUFACTURING, TENDERING OR FOR ANY OTHER PURPOSE WITHOUT THEIR WRITTEN PERMISSION.

TOLERANCES

X. = ± 1 mm
 X.X = ± 0.50 mm
 X.XX = ± 0.20 mm
 X.XXX = ± 0.01 mm
 ANGLES = $\pm 5^\circ$
 UNLESS STATED

MATERIAL:

SEE SHEET 3

FINISH:

SEE SHEET 3

S/AREA:

mm²

TITLE:

MULTI-DIRECTIONAL SPRING CONTACT
IN TAPE AND REEL

DRAWING NUMBER:

S1961-46R

SHT
2 OF 3

Customer Information Sheet

DRAWING No.: S1961-46R

IF IN DOUBT - ASK

©

NOT TO SCALE

THIRD ANGLE PROJECTION

ALL DIMENSIONS IN mm

**S1961-46R
DEFLECTION FROM ABOVE**

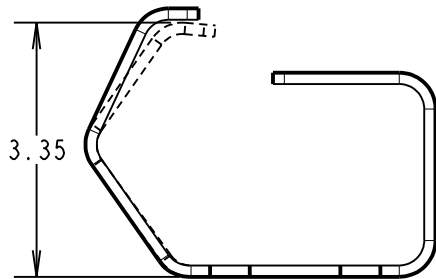

RECOMMENDED WORKING HEIGHT
OF 3.35mm = 0.20mm DEFLECTION,
MINIMUM FORCE OF 1.2N

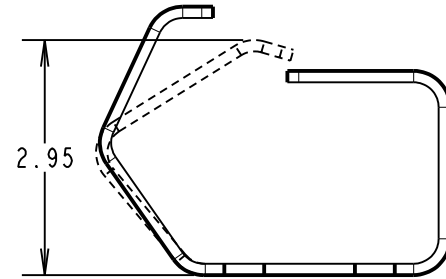

MINIMUM RECOMMENDED HEIGHT
OF 2.95mm = 0.60mm DEFLECTION

**S1961-46R
DEFLECTION FROM FRONT**

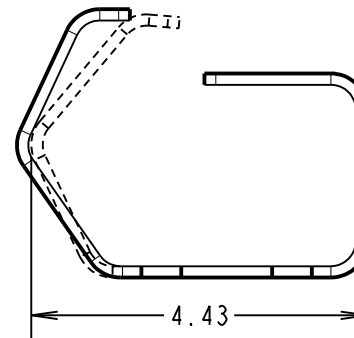

RECOMMENDED WORKING LENGTH
OF 4.43mm = 0.20mm DEFLECTION
MINIMUM FORCE OF 1.2N

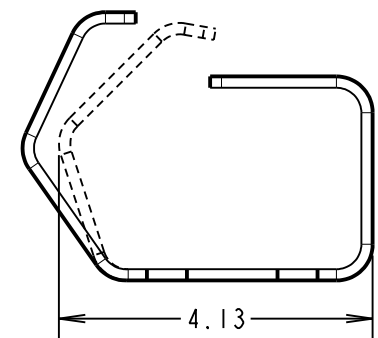

MINIMUM RECOMMENDED LENGTH
OF 4.13mm = 0.50mm DEFLECTION

COMPONENT SPECIFICATION:
 MATERIAL = CUPRO NICKEL
 FINISH = 3µm 100% TIN OVER 2µm NICKEL
 ELECTRICAL:
 CURRENT RATING = 14A
 CONTACT RESISTANCE = 2mΩ MAX.
 MECHANICAL:
 DURABILITY = 5,000 CYCLES
 OPERATING TEMPERATURE: -55°C to +125°C

RTP	1	20.04.21	30447
NAME	ISS.	DATE	CN/CO
APPROVED: S.BENNETT			
CHECKED: R.ALEXANDER			
DRAWN: R.PORTLOCK			
CUSTOMER REF.:			
ASSEMBLY DRG:			

HARWIN

www.harwin.com
technical@harwin.com

THIS DRAWING AND ANY
INFORMATION OR DESCRIPTIVE
MATTER SET OUT HEREON ARE
CONFIDENTIAL AND COPYRIGHT
PROPERTY OF THE HARWIN
GROUP AND MUST NOT BE
DISCLOSED, LOANED, COPIED
OR USED FOR MANUFACTURING,
TENDERING OR FOR ANY
OTHER PURPOSE WITHOUT
THEIR WRITTEN PERMISSION.

TOLERANCES
 X. = ±1mm
 X.X = ±0.50mm
 X.XX = ±0.20mm
 X.XXX = ±0.01mm
 ANGLES = ±5°
 UNLESS STATED

MATERIAL:

SEE ABOVE

FINISH: SEE ABOVE

S/AREA: mm²

TITLE:

MULTI-DIRECTIONAL SPRING CONTACT
IN TAPE AND REEL

DRAWING NUMBER:

S1961-46R

SHT
3
OF
3