

# Customer Information Sheet

DRAWING No.: M80-500000MI-04-331-00-000

SHEET 2 OF 2

IF IN DOUBT - ASK

©

NOT TO SCALE

THIRD ANGLE PROJECTION

ALL DIMENSIONS IN mm

## SPECIFICATIONS:

### MATERIAL:

MOULDING: GLASS FILLED PPS, UL94V-0, BLACK  
POWER CONTACT: BRASS  
JACKSCREW: STAINLESS STEEL

### FINISH:

POWER CONTACT: GOLD

### ELECTRICAL:

WORKING VOLTAGE = 120V AC/DC  
VOLTAGE PROOF = 360V AC/DC  
INSULATION RESISTANCE = 100MΩ MIN

### POWER CONTACT:

CONTACT RESISTANCE 6 mΩ MAX  
CURRENT RATING = 20A MAX

### MECHANICAL:

DURABILITY = 500 OPERATIONS

### POWER CONTACT:

INSERTION FORCE = 5N MAX  
WITHDRAWAL FORCE = 0.5N MIN

### ENVIRONMENTAL:

TEMPERATURE RANGE = -55°C TO +125°C

### PACKING:

TRAY

FOR COMPLETE SPECIFICATION SEE COMPONENT SPECIFICATION C005XX (LATEST ISSUE)

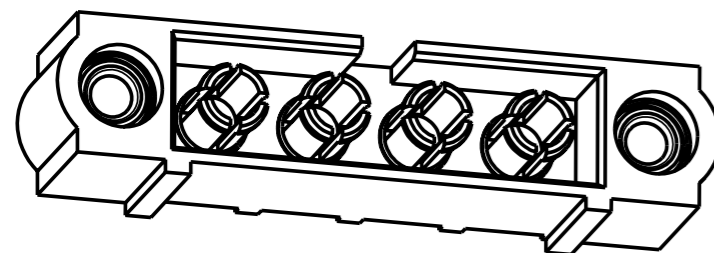
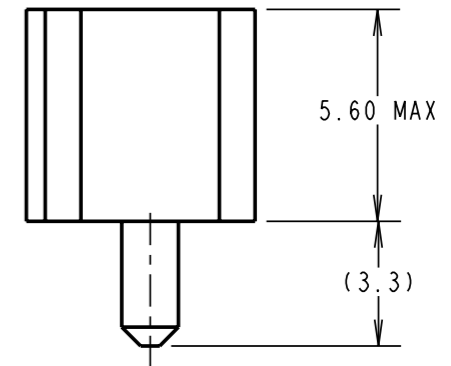
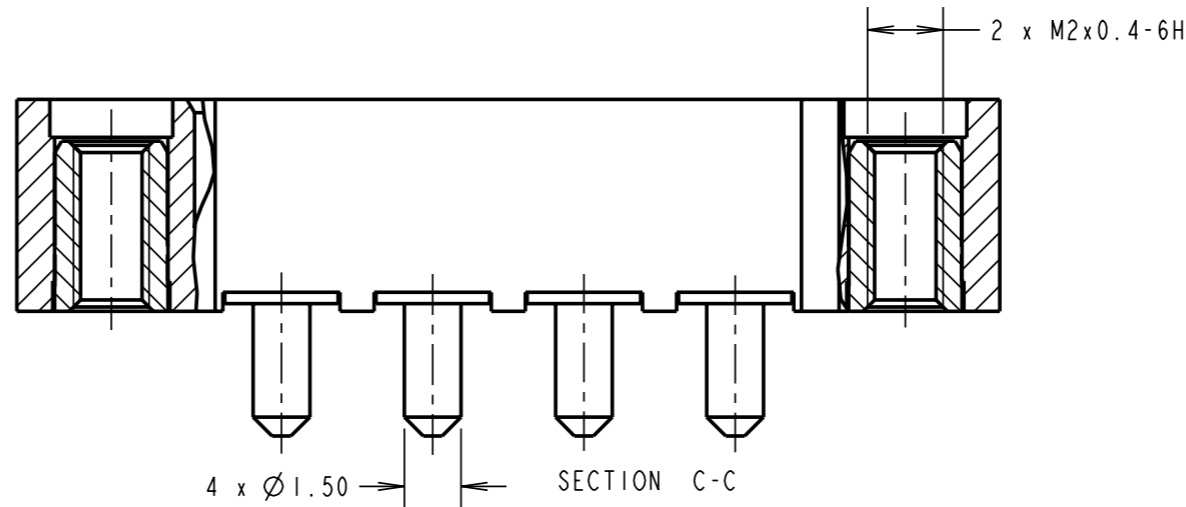
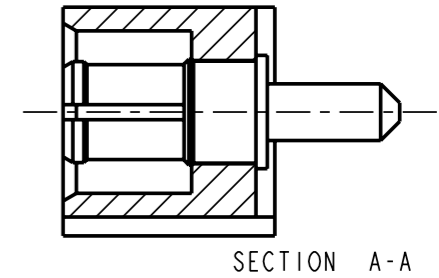
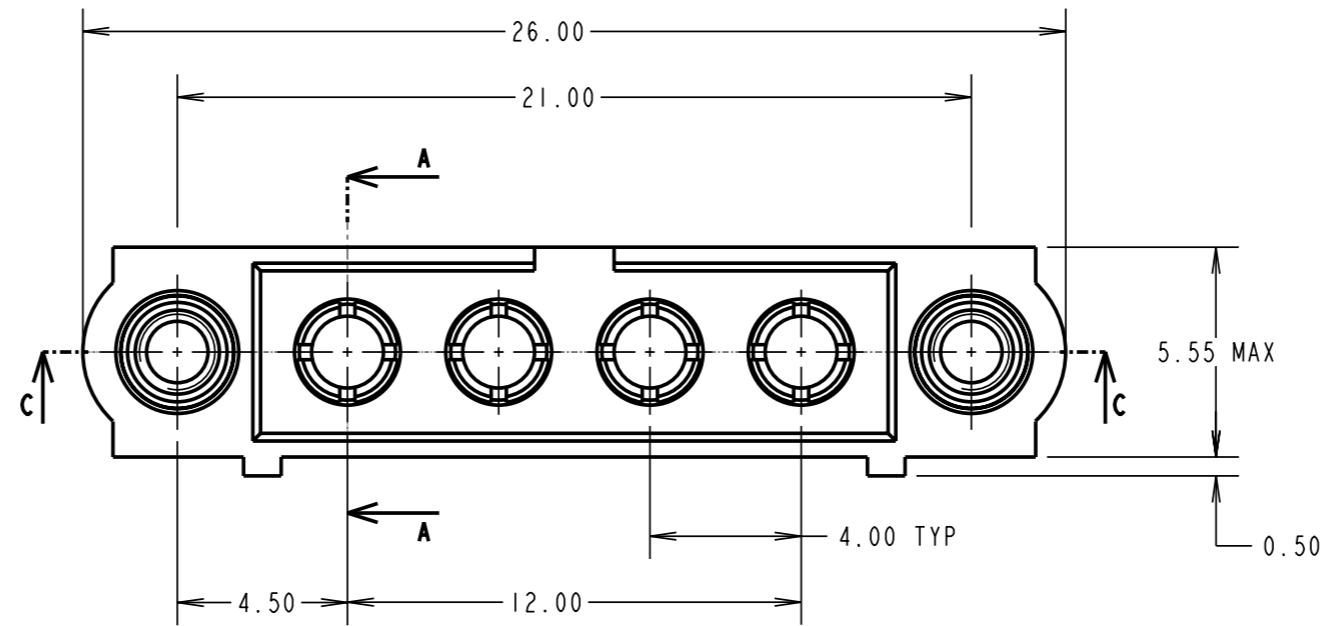

SCALE 3.5

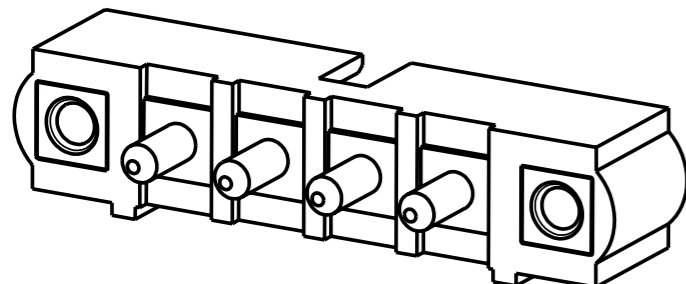

### RECOMMENDED PCB LAYOUT

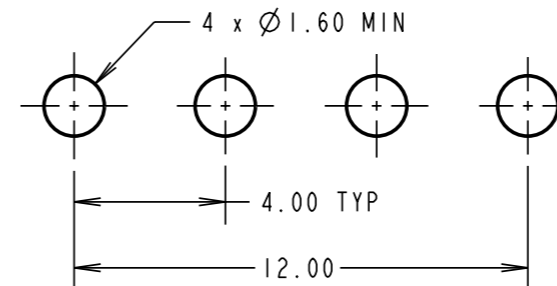

MGP	A	13.06.06	----
NAME	ISS.	DATE	C/NOTE
APPROVED:		PDC	
CHECKED:		JMB	
DRAWN:		M. G. PLESTED	
CUSTOMER REF.:			
ASSEMBLY DRG:			

<b>HARWIN</b>			THIS DRAWING AND ANY INFORMATION OR DESCRIPTIVE MATTER SET OUT HEREON ARE CONFIDENTIAL AND COPYRIGHT PROPERTY OF THE HARWIN GROUP AND MUST NOT BE DISCLOSED, LOANED, COPIED OR USED FOR MANUFACTURING, TENDERING OR FOR ANY OTHER PURPOSE WITHOUT THEIR WRITTEN PERMISSION.	TOLERANCES X. = ±1mm X.X = ±0.25mm X.XX = ±0.10mm X.XXX = ±0.01mm ANGLES = ±5° UNLESS STATED	MATERIAL: SEE ABOVE FINISH: SEE ABOVE S/AREA: mm <sup>2</sup>	TITLE: JACKSCREW DATAMATE MIXED TECHNOLOGY HORIZONTAL PC TAIL MALE ASSEMBLY	
HARWIN INC U.S.A. TEL: (812) 542 2540 FAX: (812) 542 2541	HARWIN PLC U.K. TEL: 023 9231 4545 FAX: 023 9231 4590	HARWIN PTE SINGAPORE TEL: 65 6779 4909 FAX: 65 6779 3868				DRAWING NUMBER: <b>M80-500000MI-04-331-00-000</b>	SHT 2 OF 2