

Verpackt im Gurt in Anlehnung an DIN IEC 60286-3
 tape on reel packaging according to DIN IEC 60286-3
 Verpackungseinheit: 280 Stück
 packaging unit: 280 pcs

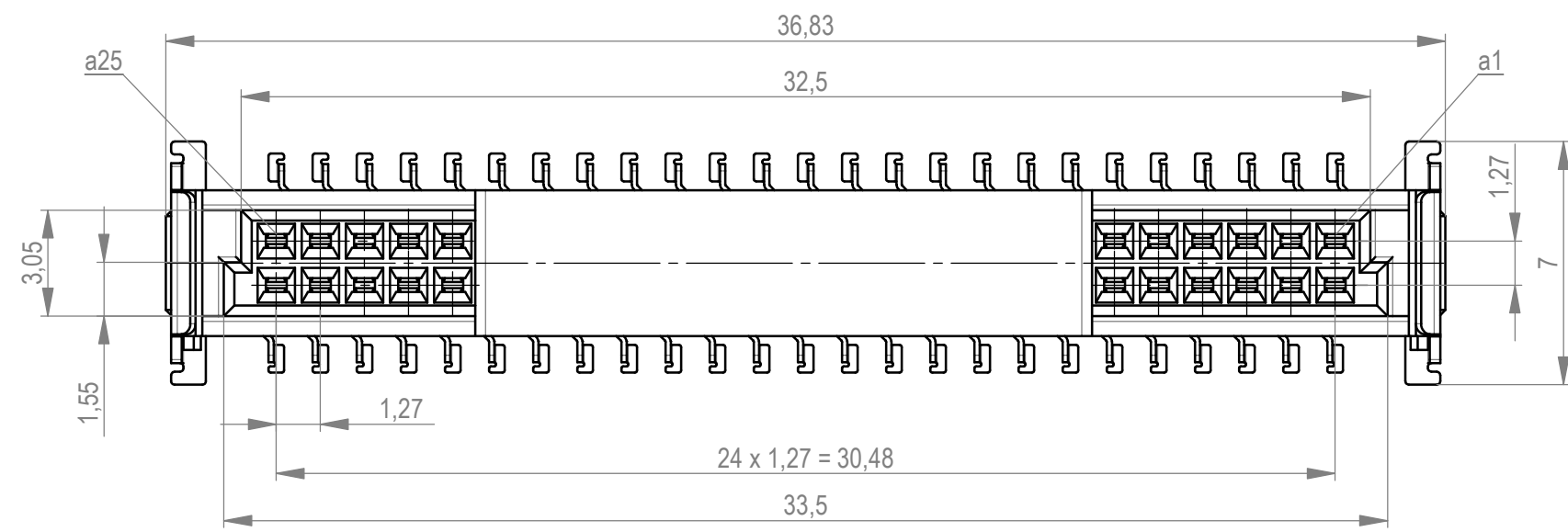

Abspulrichtung - reel off direction

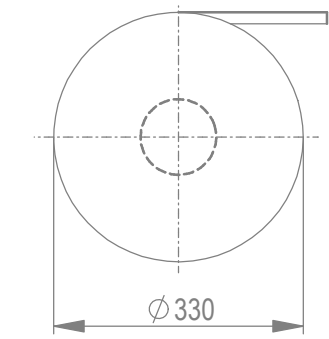
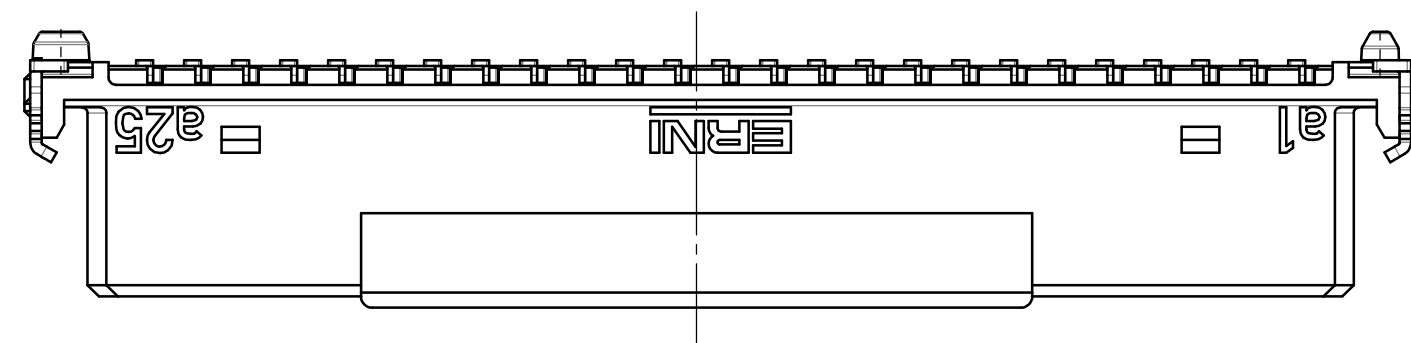
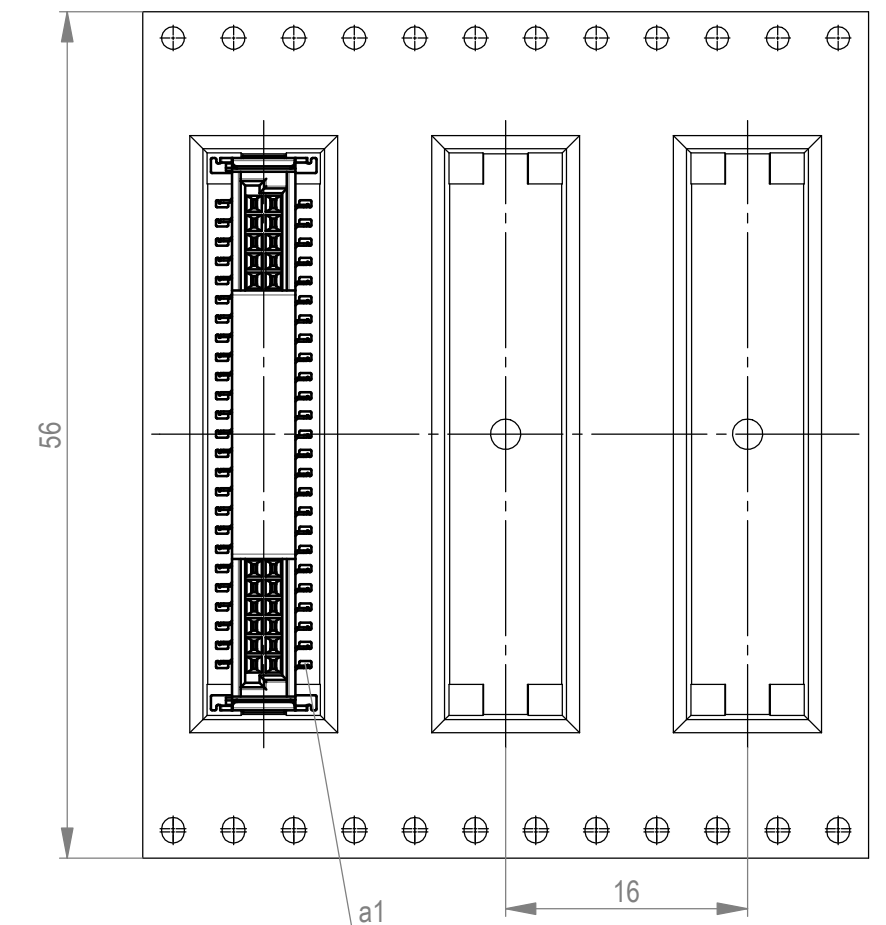

Leiterplatten-Layout Vorschlag für SMT
 PCB-Layout Proposal for SMT



- Anforderungsstufe 1
performance level 1
- Kontaktbereich vergoldet
mating area gold plating
- Anschlussbereich verzinkt 4-6 µm
terminal area 4-6 µm tin plating
- Koplanarität der Anschlüsse ≤ 0,1 mm
coplanarity area of termination ≤ 0,1 mm

BA 7-13 - 8mm Bauhöhe
 type7-13 - Low Profile

Dimension no.	Tolerances	Scale 5:1 Material
	ISO 8015	All Dimensions in mm
Customer drawing: All rights reserved. Only for information. To ensure that this is the latest version of this drawing, please contact one of the ERNI companies before using.	Subject to modification without prior notice. Drawing will not be updated.	SMC Female Straight B Type7-13 SMT 50p. Low Prof. 154807
g 08.06.2021		ERNI International AG Zürichstrasse 72 8306 Brüttisellen - Zürich Switzerland
Index Date		Class SMCB

Die deutsche Version dieser Zeichnung dient nur zur Erleichterung der Handhabung. Bei Abweichungen vom englischen Original gilt das englische Original. In case of any deviation the English version shall prevail.