

Verpackt im Gurt nach DIN IEC 60286-3
 Tape on Reel Packaging according to DIN IEC 60286-3
 Verpackungseinheit: 250 Stück
 Packaging unit: 250 pcs

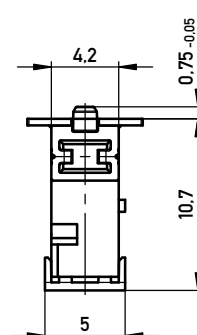

Abspulrichtung - Reel off Direction

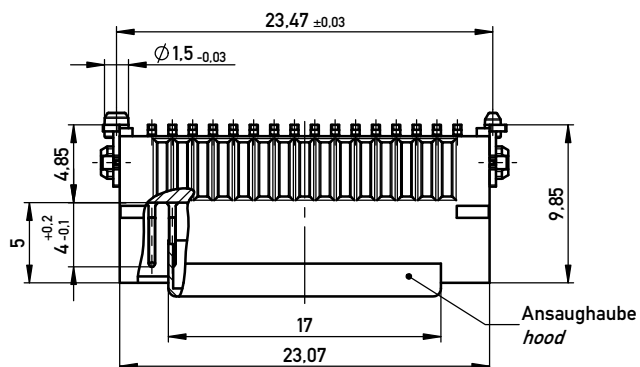
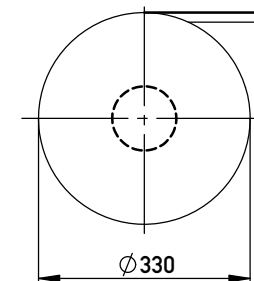
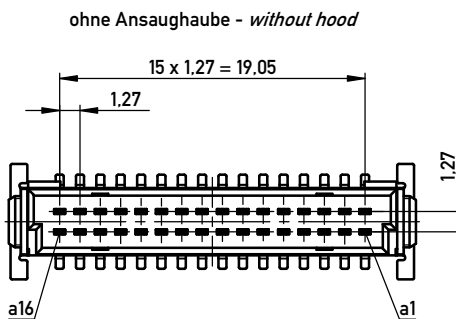
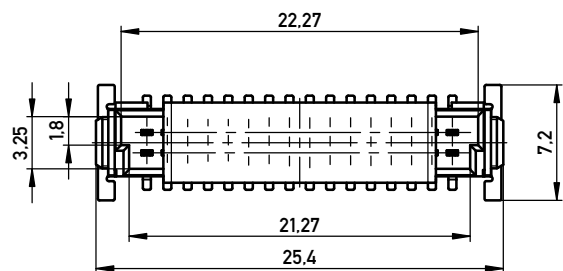
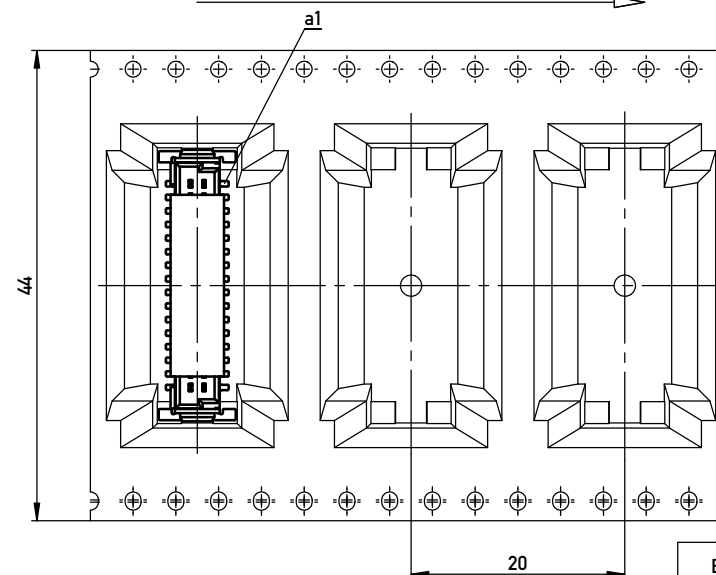

Leiterplatten-Layout Vorschlag für SMT
 PCB-Layout Proposal for SMT

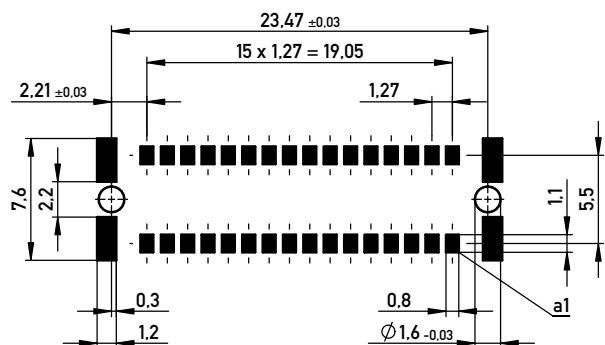

Anforderungsstufe 1
 Performance Level 1

Kontaktbereich vergoldet
 Mating Area gold plating

Anschlussbereich verzinkt 4-6 µm
 Terminal Area 4-6 µm tin plating

Koplanarität der Anschlüsse ≤ 0,1 mm
 Coplanarity Area of Termination ≤ 0,1 mm

BA 8-23 - hohe Bauhöhe
 type 8-23 - High Profile

Copyright by ERNI GmbH
 Proprietary notice pursuant to ISO 9006 to be observed.

Information:		Tolerances	 All Dimensions in mm	Scale	3:1
All rights reserved. Only for Information. To ensure that this is the latest version of this drawing, please contact one of the ERNI companies before using.		Subject to modification without prior notice. Drawing will not be updated.		Designation	
		www.ERNI.com		Messertl. SMC-Q 32-SMD-BA8-23 Male SMC-Q 32-SMD-type8-23	
e	26.06.2015			254416	
Index	Date			I A3	
				Class	SMCQ