

Leiterplatten-Layout Vorschlag / PCB-layout proposal

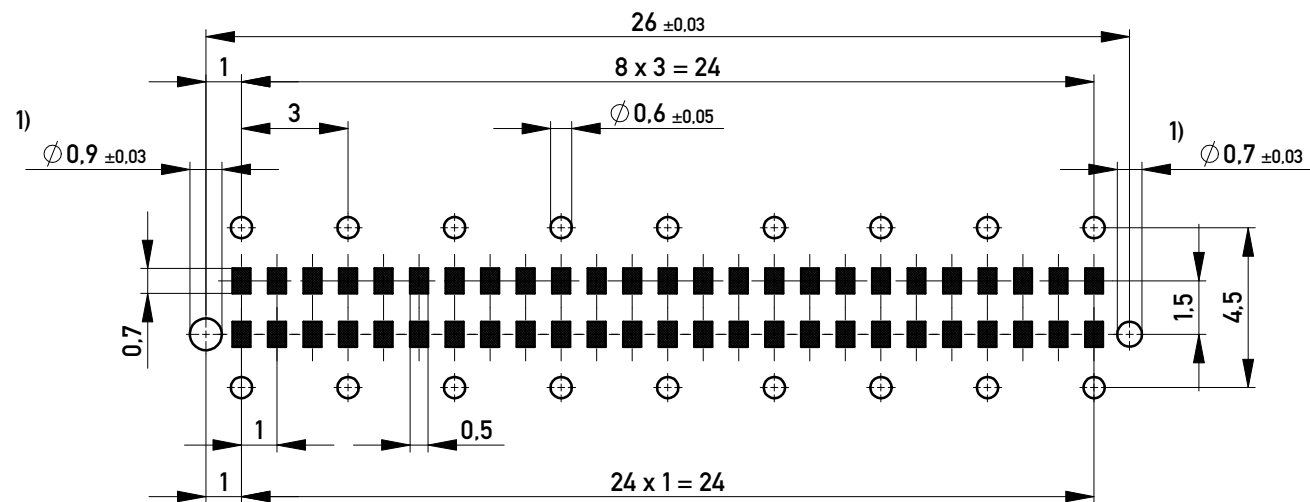

1) Durchmesser des Bohrers / drill tool

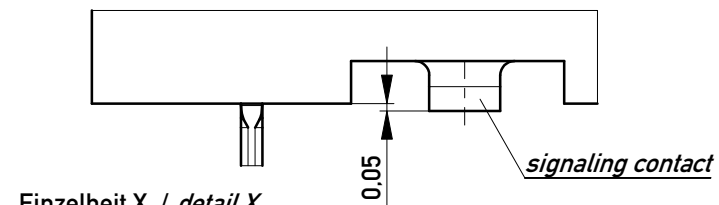
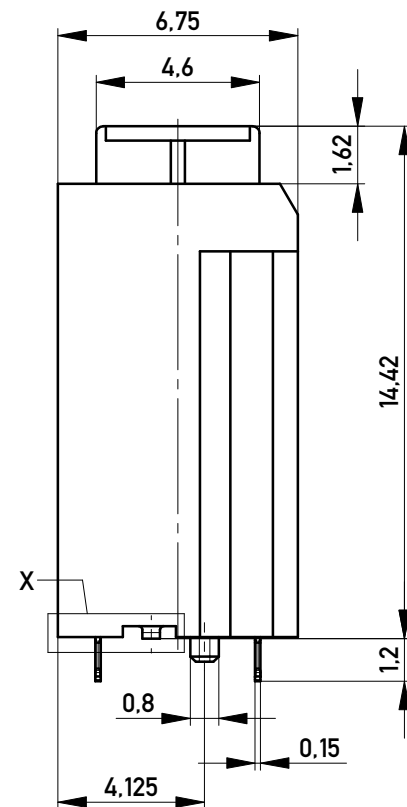

Einzelheit X / detail X
M 20:1 / scale 20:1

Verpackt im Gurt in Anlehnung an DIN IEC 60286-3
tape on reel packaging according to DIN IEC 60286-3
Verpackungseinheit: 170 Stück
packaging unit: 170 pcs

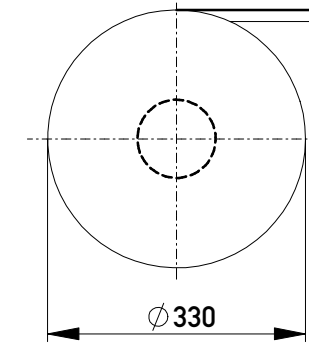

Abspulrichtung - Reel off Direction

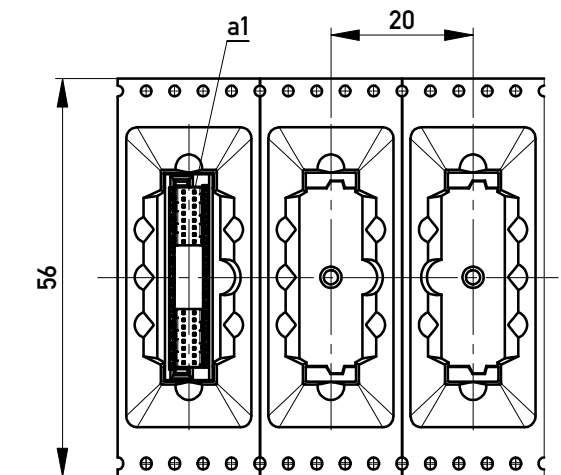

Anforderungsstufe 1
Performance Level 1

Kontaktbereich vergoldet
Mating Area gold plating

Anschlussbereich verzinkt 4-6 µm
Terminal Area 4-6 µm tin plating

Koplanarität der Anschlüsse ≤ 0.1 mm
Coplanarity Area of Termination ≤ 0.1 mm

Information:	Tolerances	 All Dimensions in mm	Scale	5:1
	All rights reserved. Only for Information. To ensure that this is the latest version of this drawing, please contact one of the ERNI companies before using.		Designation M09 MSPEED Blind Mate 50 THR	
g	01.09.2017	 www.ERNI.com	354186	
Index	Date			
				I A3

Copyright by ERNI GmbH
Proprietary notice pursuant to ISO 16016 to be observed.