

Verpackt in Gurtverpackung - *Tape on Reel Packaging*
 Verpackungseinheit: 300 Stück - *Packaging unit: 300 pcs*

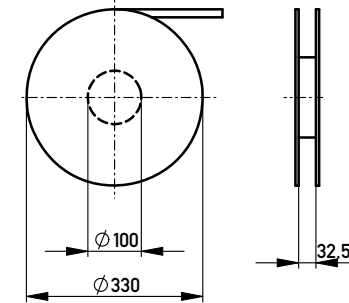

Abspulrichtung - *Reel off Direction* →

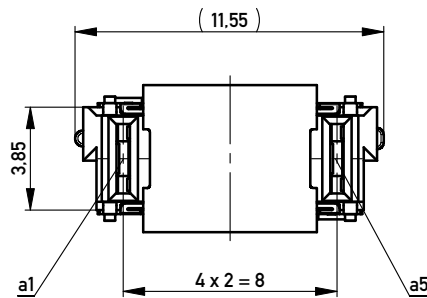

Anforderungsstufe 1
Performance Level 1

Kontaktbereich vergoldet
Mating Area gold plating

Anschlussbereich verzinkt 4-6µm
Terminal Area 4-6µm tin plating

Koplanarität der Anschlüsse ≤ 0,1mm
Coplanarity Area of Termination ≤ 0,1mm

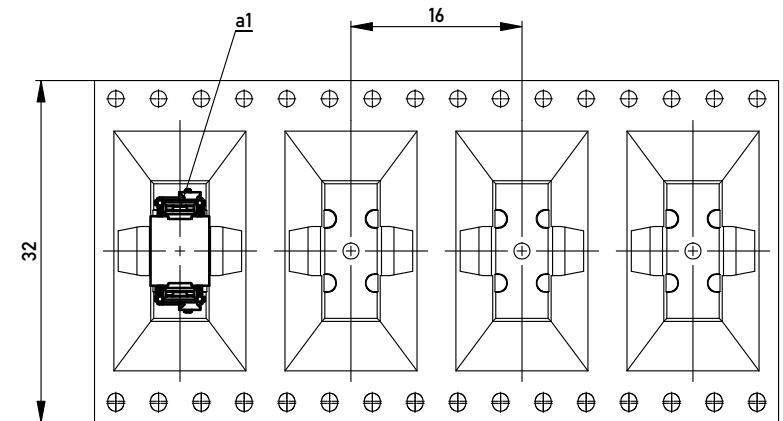

Leiterplatten-Layout Vorschlag / *PCB-layout proposal*

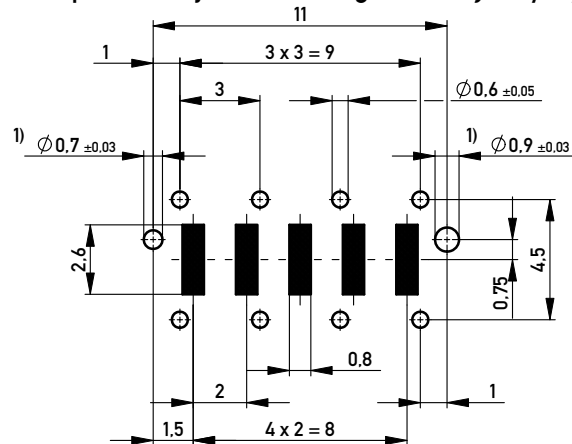

1) Durchmesser des Bohrers / *Drill tool*

Information:		Tolerances	Scale 5:1
All rights reserved. Only for Information. To ensure that this is the latest version of this drawing, please contact one of the ERNI companies before using.		All Dimensions in mm	Designation Federleiste THR, Powerm. 10mm <i>Female Con. THR, Powerm. 10mm</i>
f	06.10.2010	Class MSPEED	
Index	Date		

Copyright by ERNI GmbH. Proprietary notice pursuant to ISO 16106 to be observed.