

Leiterplatten-Layout Vorschlag / PCB-layout proposal

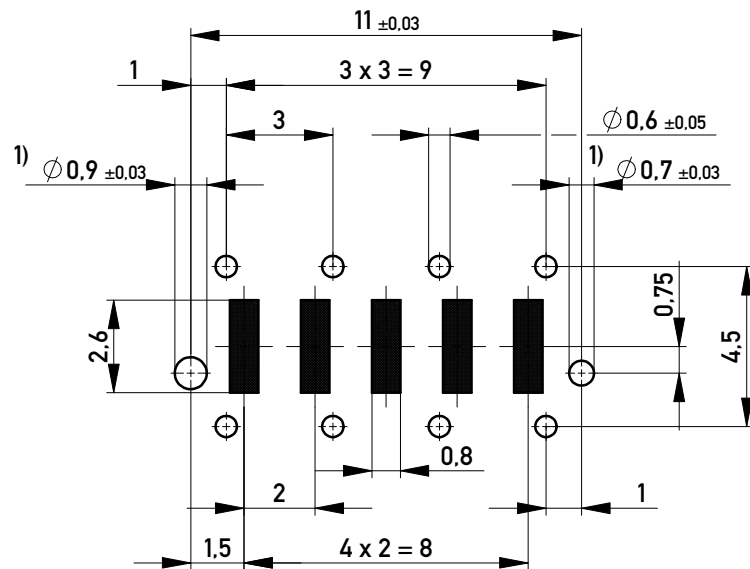

1) Durchmesser des Bohrers / Drill tool

Verpackt im Gurt nach DIN IEC 60286-3  
 Tape on Reel Packaging according to DIN IEC 60286-3  
 Verpackungseinheit: 220 Stück  
 Packaging unit: 220 pcs

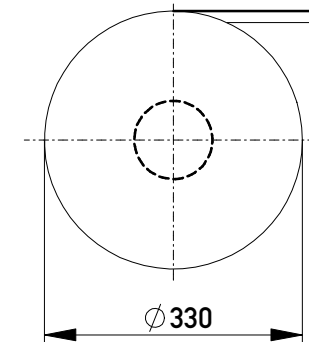

Abspulrichtung - Reel off Direction

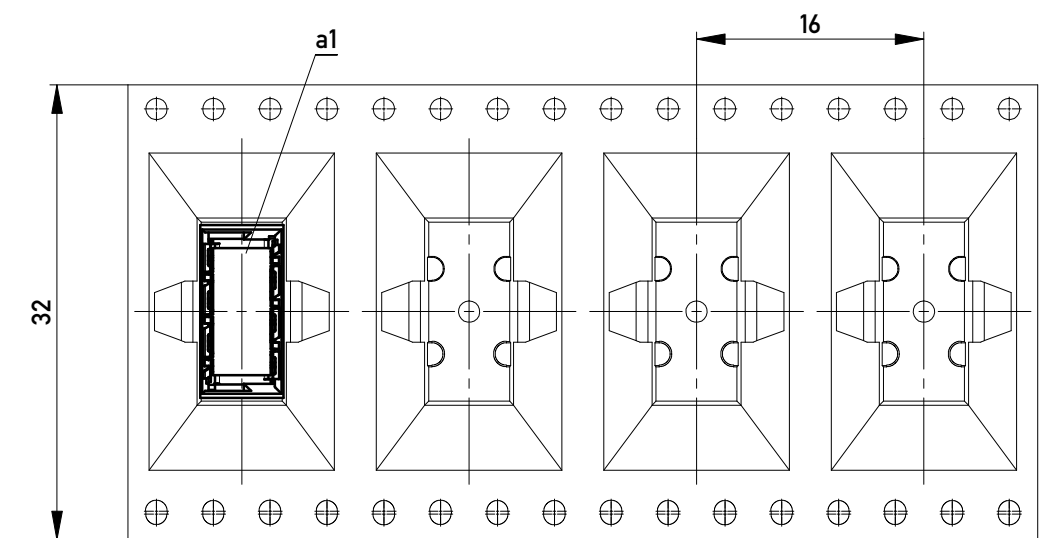



Anforderungsstufe 1  
 Performance Level 1

Kontaktbereich vergoldet  
 Mating Area gold plating

Anschlussbereich verzinkt 4-6 µm  
 Terminal Area 4-6 µm tin plating

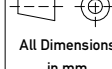
Koplanarität der Anschlüsse ≤ 0.1 mm  
 Coplanarity Area of Termination ≤ 0.1 mm

Information:  All rights reserved. Only for Information. To ensure that this is the latest version of this drawing, please contact one of the ERNI companies before using.	Tolerances   All Dimensions in mm	Scale	5:1
		Designation <b>Messerleiste THR, Powerm. 10mm</b> <b>Male Con. THR, Powerm. 10mm</b>	
k Index	06.02.2014 Date	 www.ERNI.com	<b>214919</b> I A3
		Class	MSPEED

Copyright by ERNI GmbH  
 Proprietary notice pursuant to ISO 16016 to be observed.