

ZONE	REV	ECN NUMBER	DESCRIPTION	BY	DATE	APPROVED
	E	BWAG-18101704	UPDATED NOTE 1. ADDED NOTE 11 & 12. REVISED BASE THICKNESS TOLERANCE 0.10 WAS 0.13. ADDED SURFACE GROUND PLANE.	HCL-UD	10/29/2018	B.WANG
SHT1, C3	F	HHUG-20010801	ADDED PLATING OPTION "P" TO P/N TREE	HCL-SG	01/23/2020	H.HUANG
SHT9	G	HHUG-20090906	ADDED SE MODULE PCB DETAILS.	HCL-SH	10/06/2020	H.HUANG

NOTE: ONLY THREE MOST RECENT RELEASED REVISIONS DISPLAYED.

XCede HD2 BACKPLANE MODULE MALE STANDARD LOAD

9 7 2 - 4 X 1 J - X 0 X

4 PAIR

4-POSITION

LETTER	PLATING
D	NI SULFAMATE, STANDARD GOLD, LEADFREE
E	NI SULFAMATE, HIGH GOLD, LEADFREE
H	NANO NI, STANDARD GOLD, LEADFREE
J	NANO NI, HIGH GOLD, LEADFREE
P	Pd-NI, STANDARD GOLD, LEADFREE

NUMBER	SIGNAL & GROUND WIPE LENGTH, COMPLIANT PIN SIZE
G	2 mm WIPE SIGNAL, 3 mm WIPE GND, Ø.0157" DRILL
J	2 mm WIPE SIGNAL, 2 mm WIPE GND, Ø.0157" DRILL

NUMBER	WALL THICKNESS / SHIELD OPTION
1	THICK WALL, W/ EXTRA GROUND

	LETTER										
LEFT POLARIZING GUIDANCE (SEE SHEET 6)	J	A	B	C	D	E	F	G	H		
	(NO KEY) 										
RIGHT POLARIZING GUIDANCE (SEE SHEET 7)	Y	P	Q	R	S	T	U	V	W		
	(NO KEY) 										
OPEN (SEE SHEET 2)	O (ZERO)										
LEFT WALL (SEE SHEET 3)	L										
RIGHT WALL (SEE SHEET 4)	M										
TWO WALL (SEE SHEET 5)	1										

- NOTES:
- REFER TO TB-2343 FOR XCede HD2 PRODUCT SPECIFICATIONS.
  - NOTCH DESIGNATES "ROW A" SIDE OF SHROUD. NOTCH FEATURE ON OPPOSITE SIDE FROM PART MARKING.
  - SEE TB-2325 FOR PART MARKING REQUIREMENTS.
  - PLATING THICKNESS OF SIGNAL CONTACT AND GROUND CONTACT IS DETERMINED BY PLATING CODE.
  - REPAIR PROCEDURE FOR MODULE. SEE TB-2245.
  - SEE TB-2237 (XCede HD2 ROUTING GUIDELINES) FOR BOARD SPECIFIC DETAILS ON ROUTING, PLATING THICKNESS, SECONDARY DIAMETERS, PAD, ANTIPAD LOCATIONS, BACK DRILLING AND SHADOW VIAS.
  - SEE DOC C-190-0009-000 FOR TOOLING KEEPOUT ZONES.
  - BACKPLANE DATUM REFERENCE.
  - OPTIONAL HOLE/MOUNTING SCREW LOCATION FOR GROUNDED PIN OR ADDITIONAL GUIDE PIN SUPPORT. SEE DRAWING C-914-4010-000 FOR OPTIONAL HOLE DETAILS. ONLY APPLIES FOR MACHINED GUIDE PIN APPLICATIONS.
  - SHADOW VIAS (GND VIA'S) DO NOT RECEIVE COMPLIANT PINS. THEY ARE ADDED FOR IMPROVED SIGNAL INTEGRITY PERFORMANCE AND CAN CHANGE IN SIZE AND LOCATION BASED UPON THE SPECIFIC DESIGN DETAILS.
  - SURFACE GROUND PLANE EQUAL TO COMPONENT OUTLINE REQUIRED. SURFACE GROUND PLANE TO BE FREE FROM SOLDEMASK
  - ALL PLASTIC MATERIAL IS UL 94V-0 FLAMMABLE

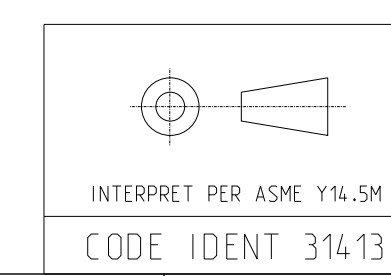
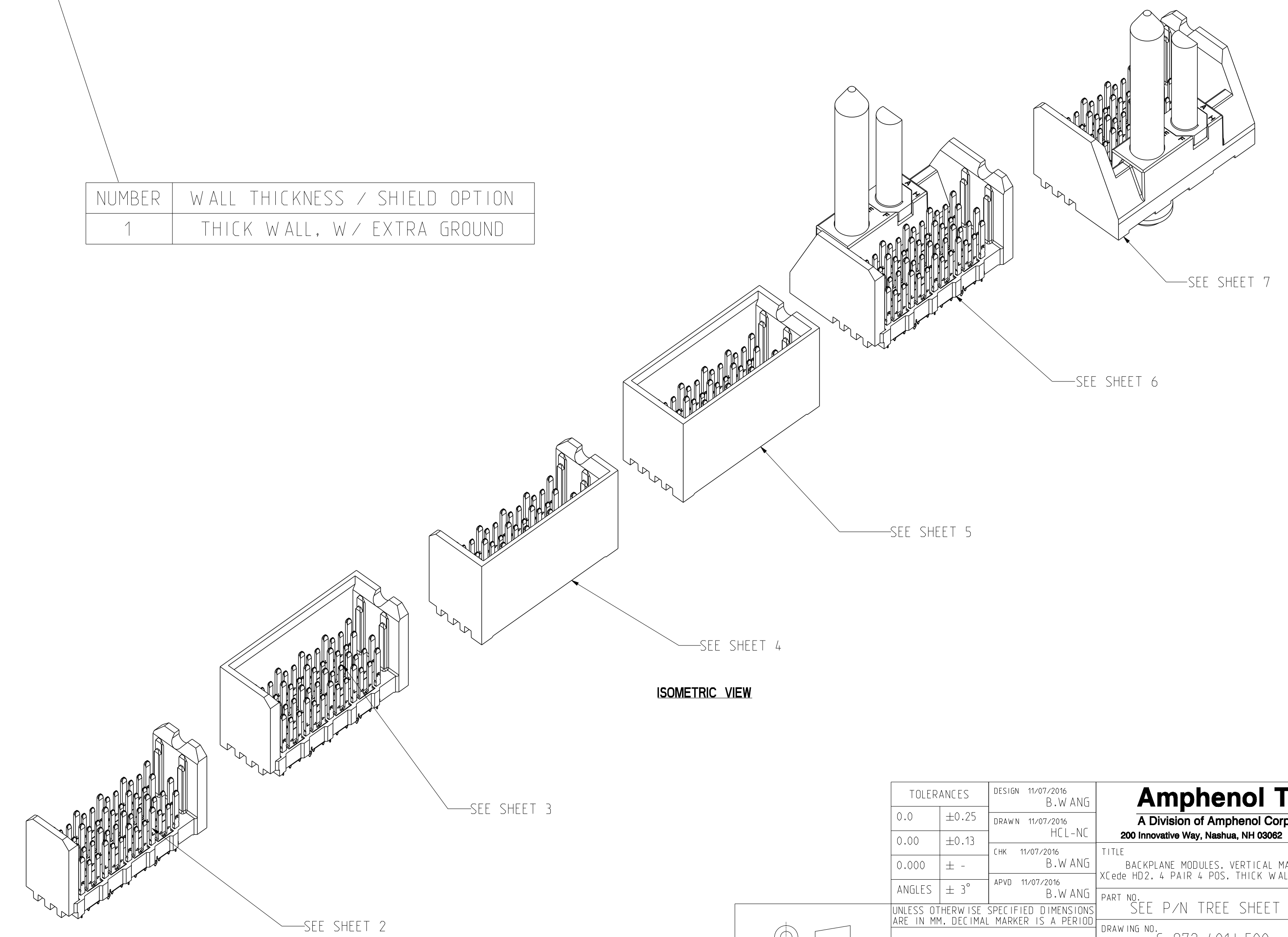

TOLERANCES	DESIGN	DATE	BY	APPROVED
0.0 ±0.25	B.WANG	11/07/2016	HCL-NC	
0.00 ±0.13	HCL-NC	11/07/2016		
0.000 ± -	B.WANG	11/07/2016		
ANGLES ± 3°	B.WANG	11/07/2016		

<b>Amphenol TCS</b> A Division of Amphenol Corporation 200 Innovative Way, Nashua, NH 03062 603.879.3000	
TITLE: BACKPLANE MODULES - VERTICAL MALE HEADER	
XCede HD2, 4 PAIR 4 POS, THICK WALL W/EXTRA GND	
PART NO. SEE P/N TREE SHEET 1	REV N/A
DRAWING NO. C-972-401J-500	REV G
UNLESS OTHERWISE SPECIFIED DIMENSIONS ARE IN MM. DECIMAL MARKER IS A PERIOD	
ASSEM C972-401J-500_XG-HD2 0.2	
DRAWING C972-401J-500_XG-HD2 0.11	
SIZE D	SCALE 1/1 SHEET 1 OF 9

CUSTOMER USE DRAWING

ZONE	REV	ECN NUMBER	DESCRIPTION	BY	DATE	APPROVED
			SEE SHEET 1			

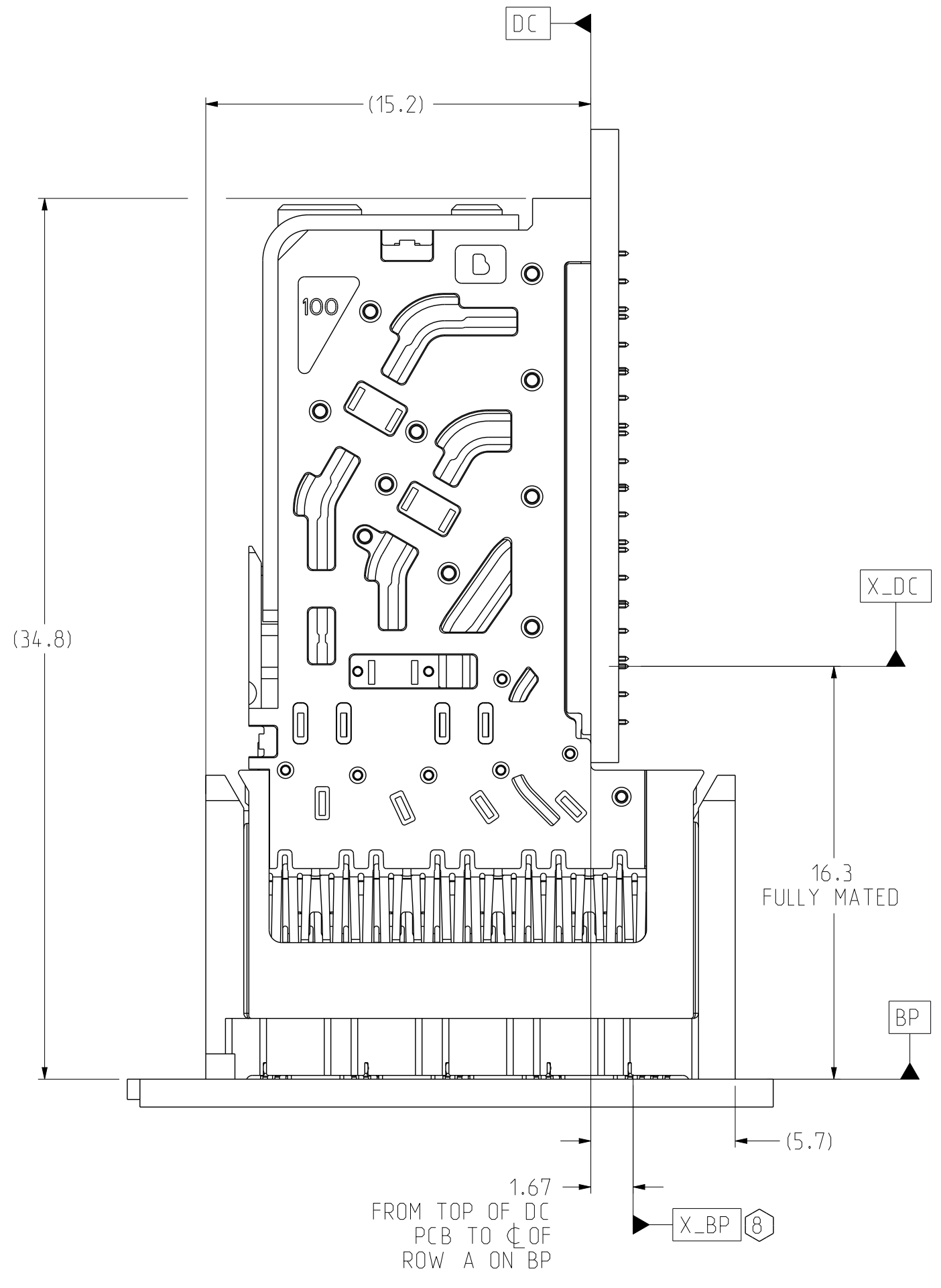
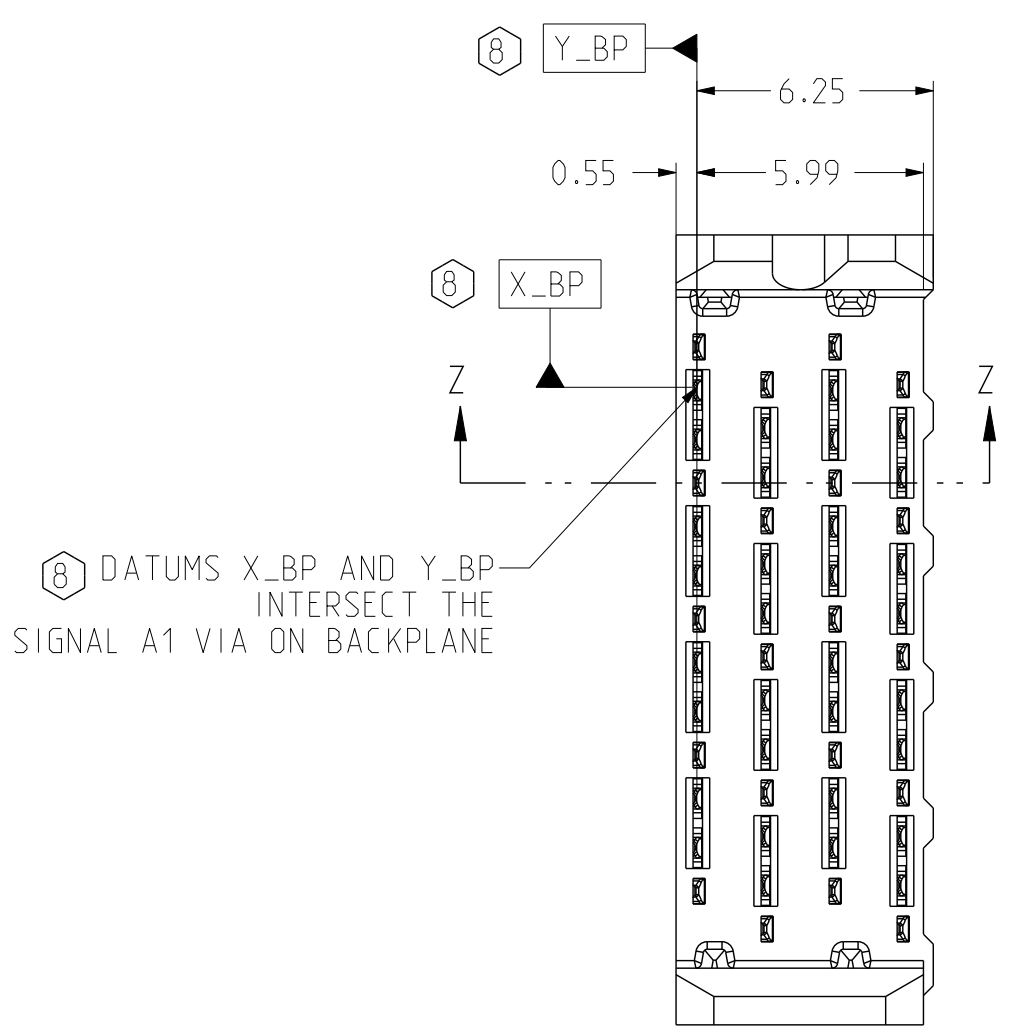

CONNECTOR REFERENCE  
SCALE 5/1

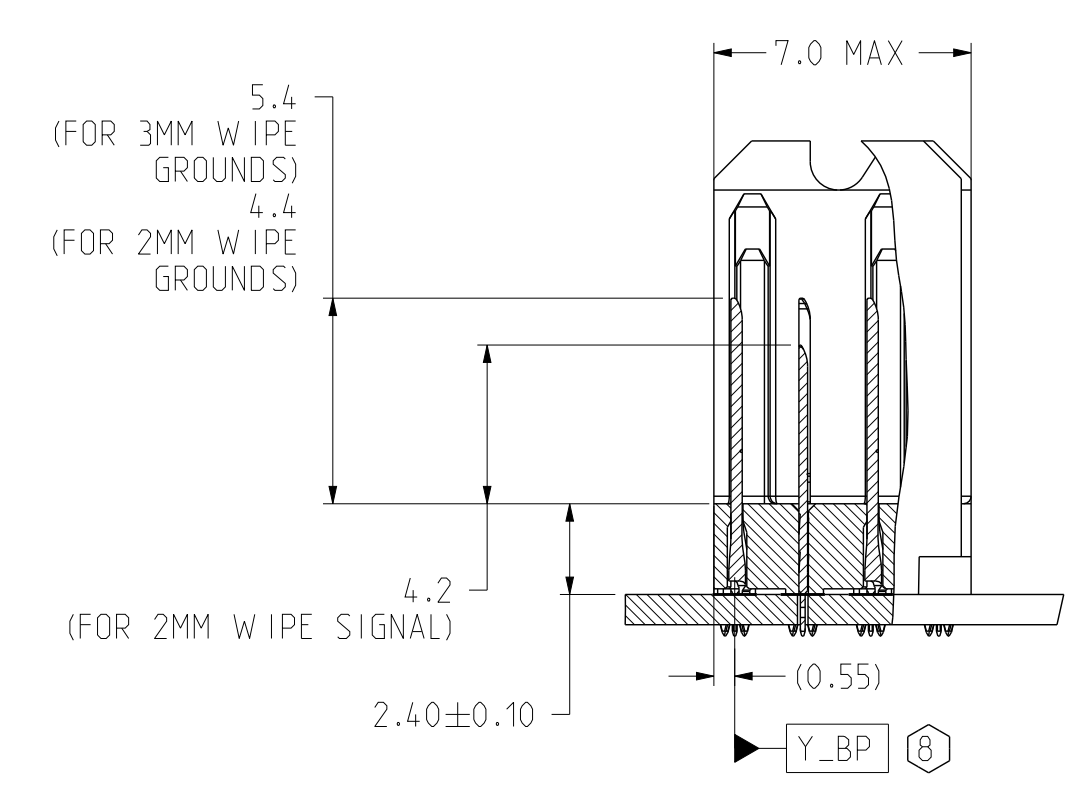

SECTION Z-Z

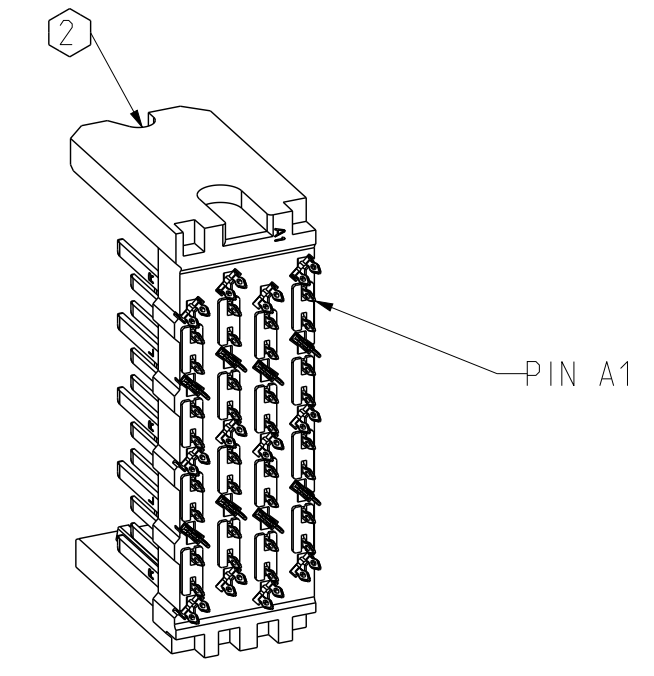
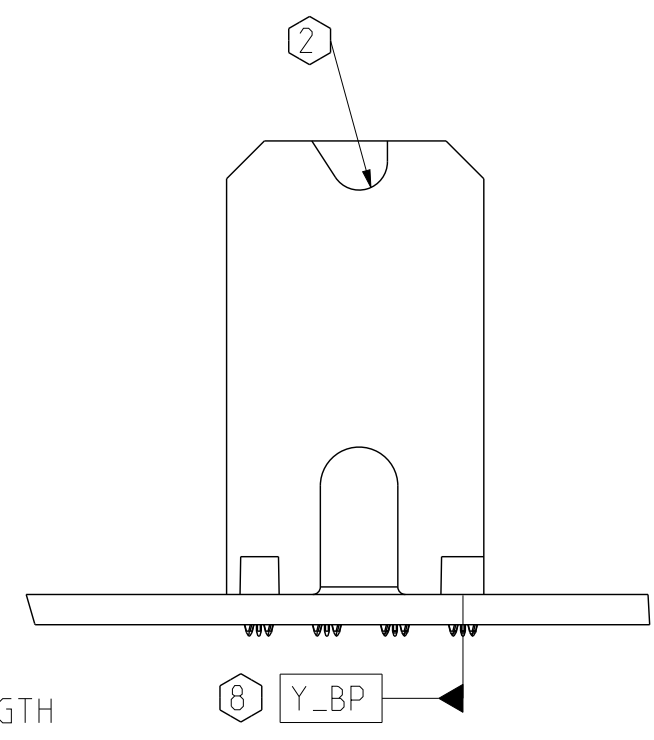
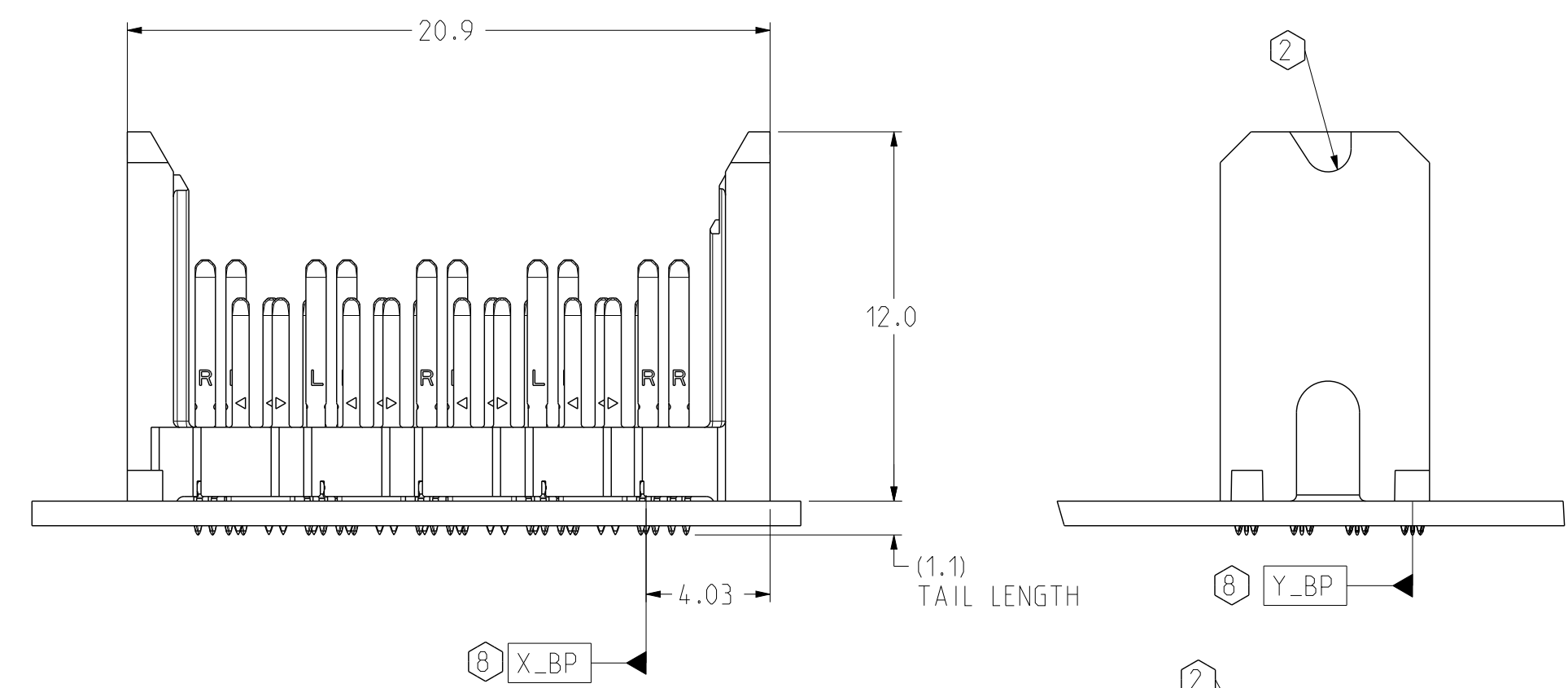

ISOMETRIC VIEW  
SCALE 3/1

OPEN BACKPLANE MODULE DIMENSION

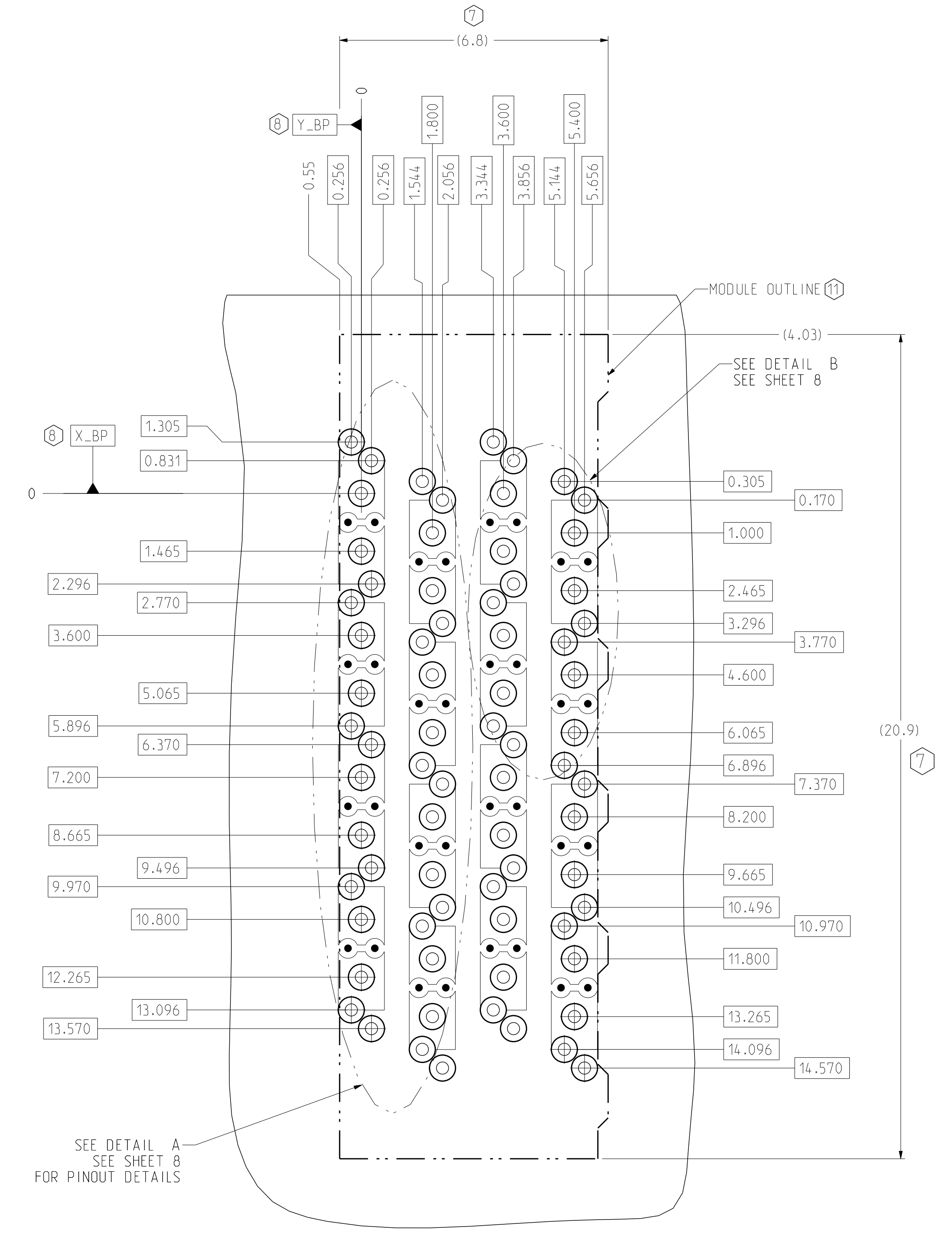

SEE DETAIL A  
SEE SHEET 8  
FOR PINOUT DETAILS

BP HOLE PATTERN  
COMPONENT SIDE  
SCALE 12/1

TOLERANCES	DESIGN 11/07/2016 B.W ANG	<b>Amphenol TCS</b> A Division of Amphenol Corporation 200 Innovative Way, Nashua, NH 03062 603.879.3000	TITLE	BACKPLANE MODULES - VERTICAL MALE HEADER
0.0 ±0.25	DRAWN 11/07/2016 HCL-NC		XCode	HD2, 4 PAIR & POS, THICK WALL W/EXTRA GND
0.00 ±0.13	CHK 11/07/2016 B.W ANG		PART NO.	SEE P/N TREE SHEET 1
0.000 ± -	APVD 11/07/2016 B.W ANG		REV	N/A
ANGLES ± 3°	UNLESS OTHERWISE SPECIFIED DIMENSIONS ARE IN MM. DECIMAL MARKER IS A PERIOD.		DRAWING NO.	C-972-401J-500
			ASSEM	C972-401J-500_XG-HD2 0.2
			DRAWING	C972-401J-500_XG-HD2 0.11
			SIZE	D
			SCALE	1/1
			SHEET	2 OF 9

INTERPRET PER ASME Y14.5M  
CODE IDENT 31413

CUSTOMER USE  
DRAWING

ZONE	REV	ECN NUMBER	DESCRIPTION	BY	DATE	APPROVED
			SEE SHEET 1			

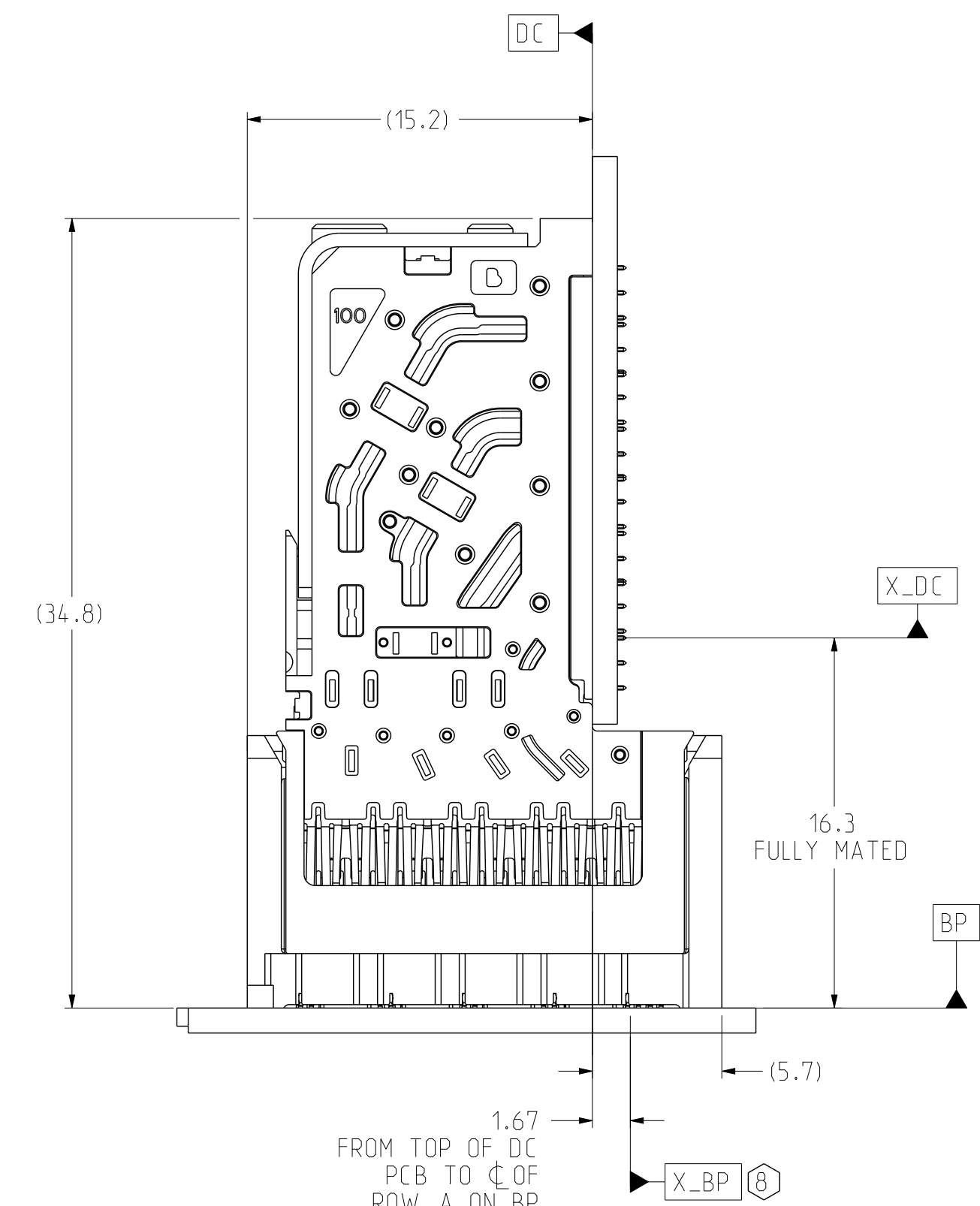
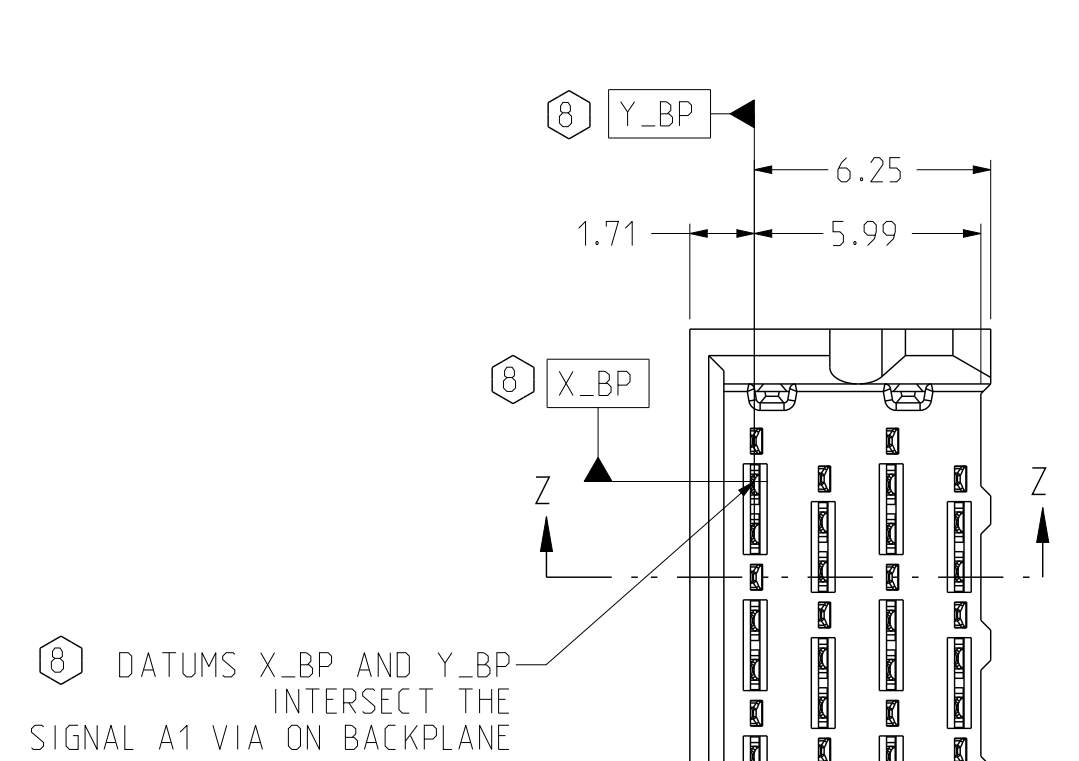

**CONNECTOR REFERENCE**  
SCALE 4/1

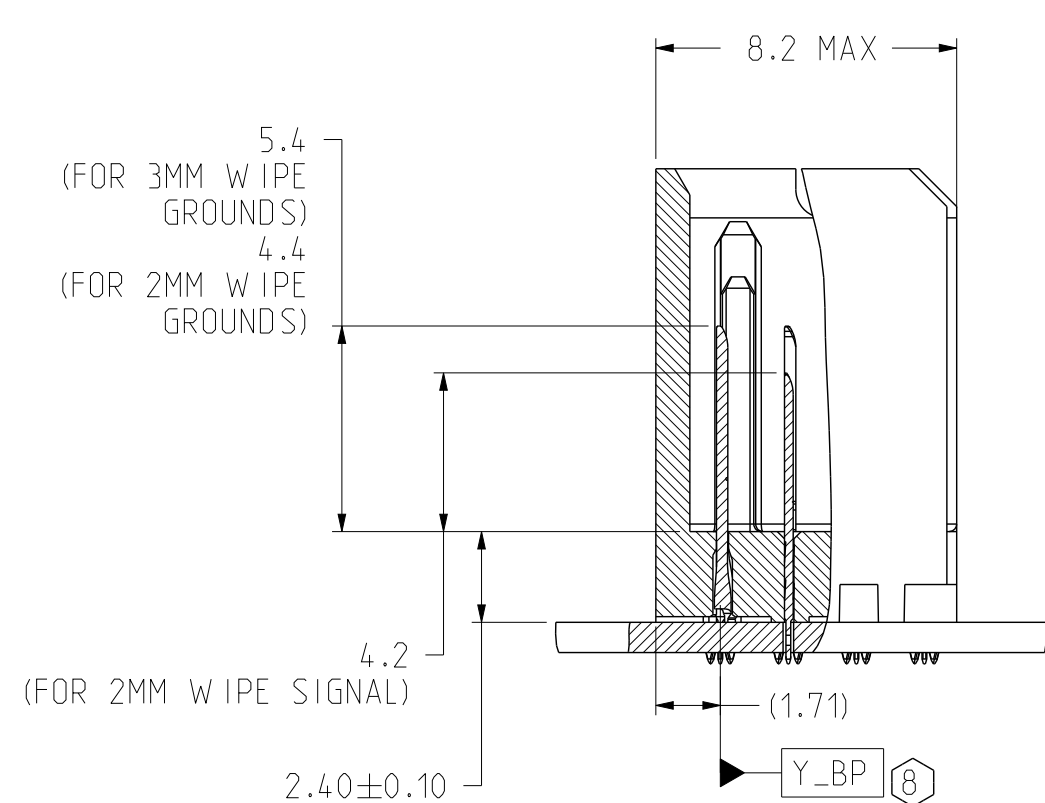

**SECTION Z-Z**

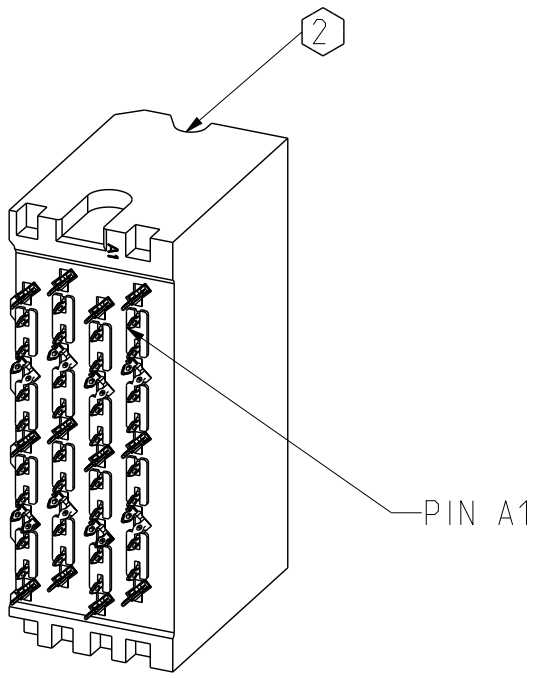
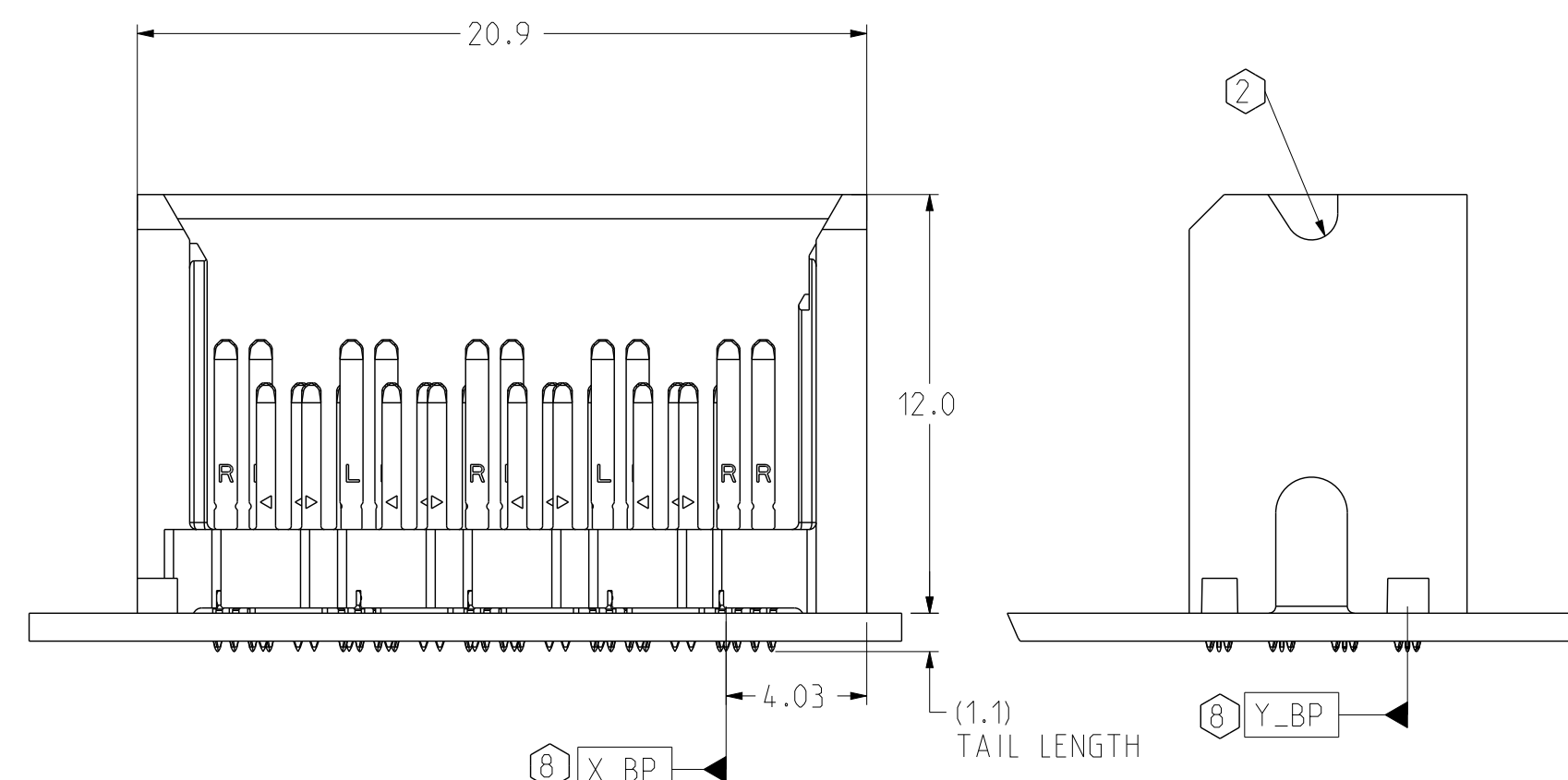

**ISOMETRIC VIEW**  
SCALE 3/1

**LEFT WALL BACKPLANE MODULE DIMENSION**

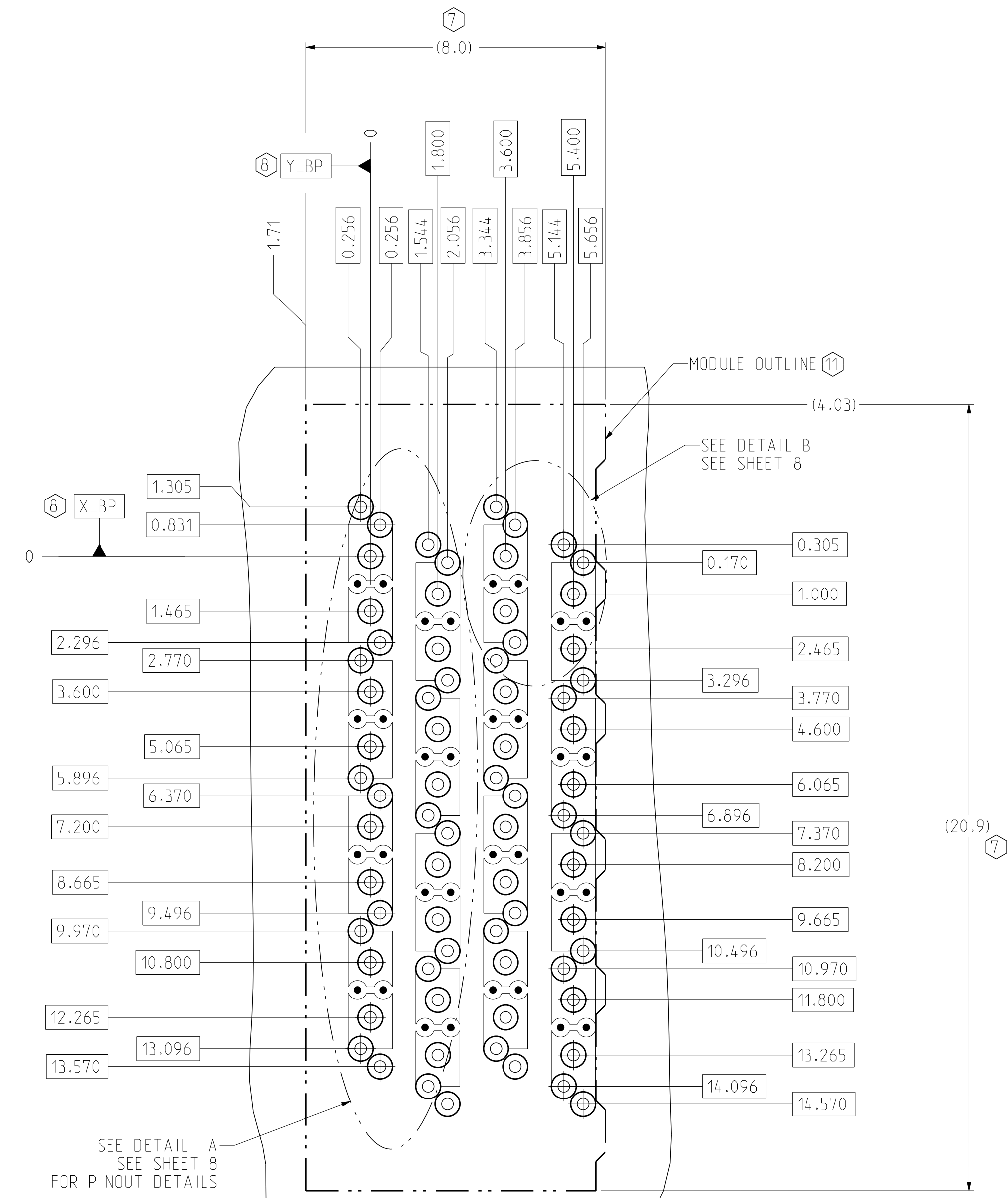

**BP HOLE PATTERN**  
**COMPONENT SIDE**  
SCALE 10/1

TOLERANCES		DESIGN 11/07/2016	B.W ANG	<b>Amphenol TCS</b> A Division of Amphenol Corporation 200 Innovative Way, Nashua, NH 03082 603.879.3000	TITLE	BACKPLANE MODULES - VERTICAL MALE HEADER
0.0	±0.25	DRAWN 11/07/2016	HCL-NC		XCode HD2, 4 PAIR & POS, THICK WALL W/EXTRA GND	
0.00	±0.13	CHK 11/07/2016	B.W ANG		PART NO.	SEE P/N TREE SHEET 1
0.000	± -	APVD 11/07/2016	B.W ANG		DRAWING NO.	C-972-401J-500
ANGLES ± 3°		UNLESS OTHERWISE SPECIFIED DIMENSIONS ARE IN MM. DECIMAL MARKER IS A PERIOD		REV	N/A	
CODE IDENT 31413		CUSTOMER USE DRAWING		ASSEM C972-401J-500_XG-HD2	0.2	
				DRAWING C972-401J-500_XG-HD2	0.11	
				SIZE D	SCALE 1/1	
				SHEET 3 OF 9		

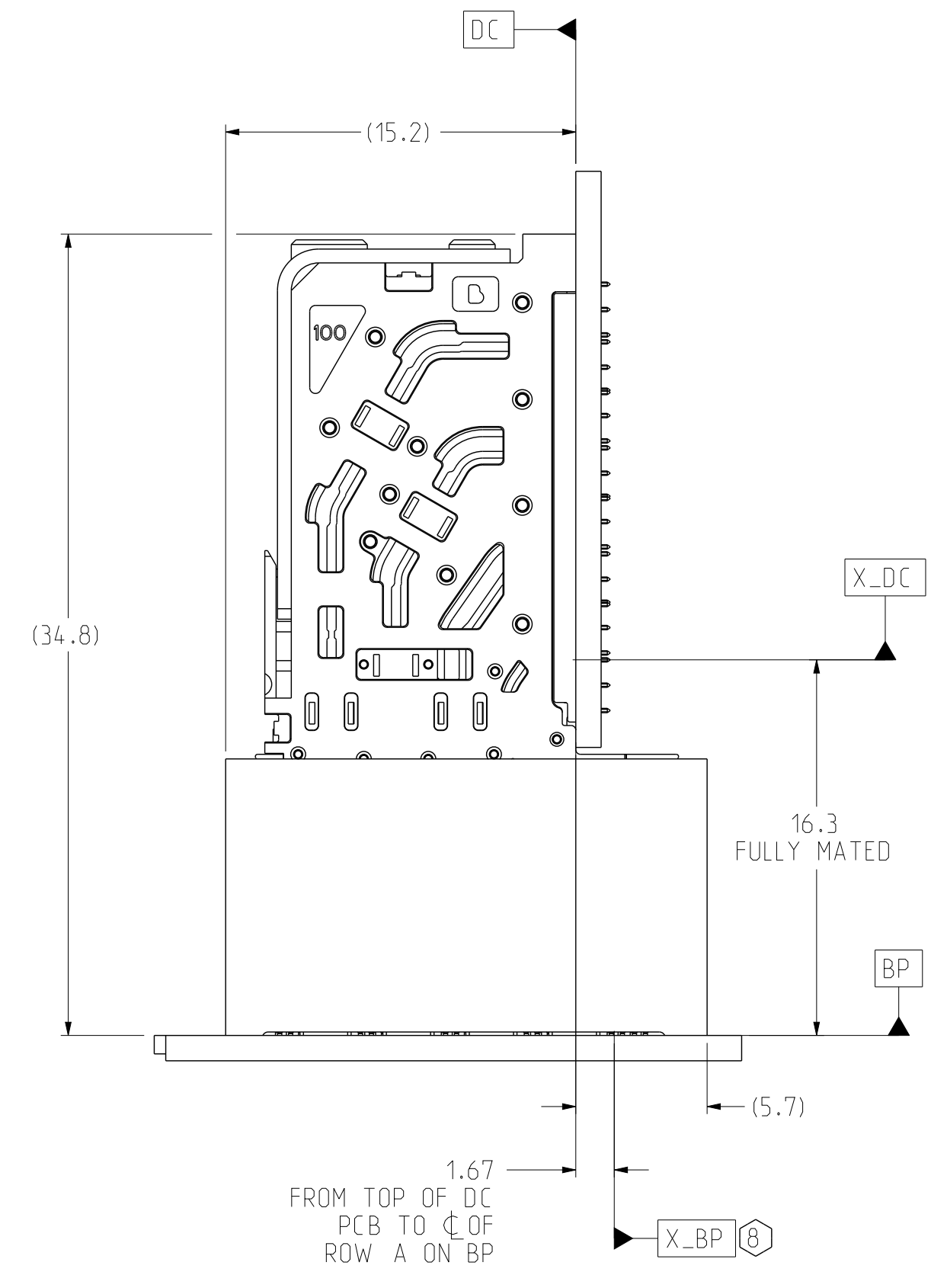
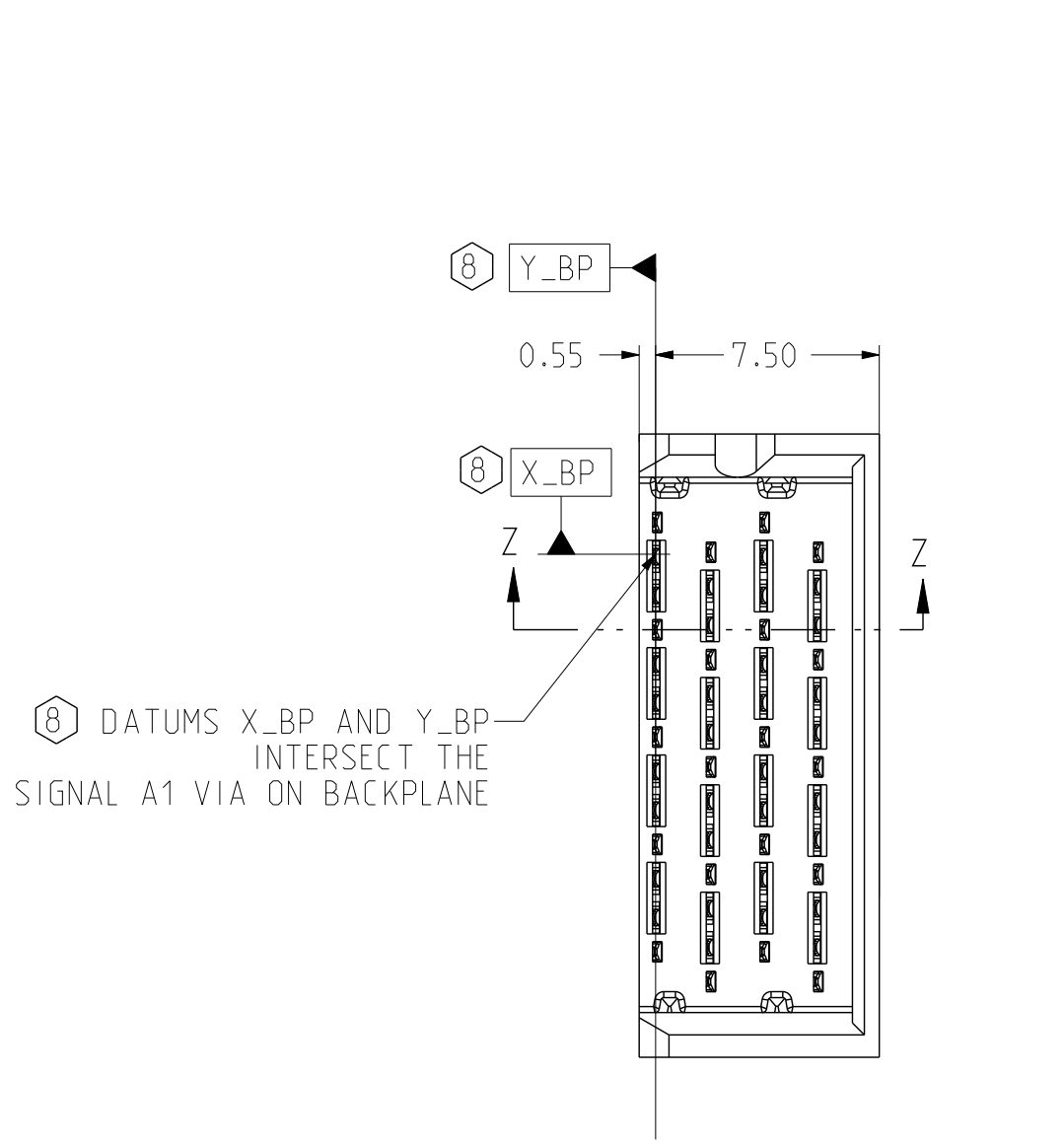

CONNECTOR REFERENCE  
SCALE 4/1

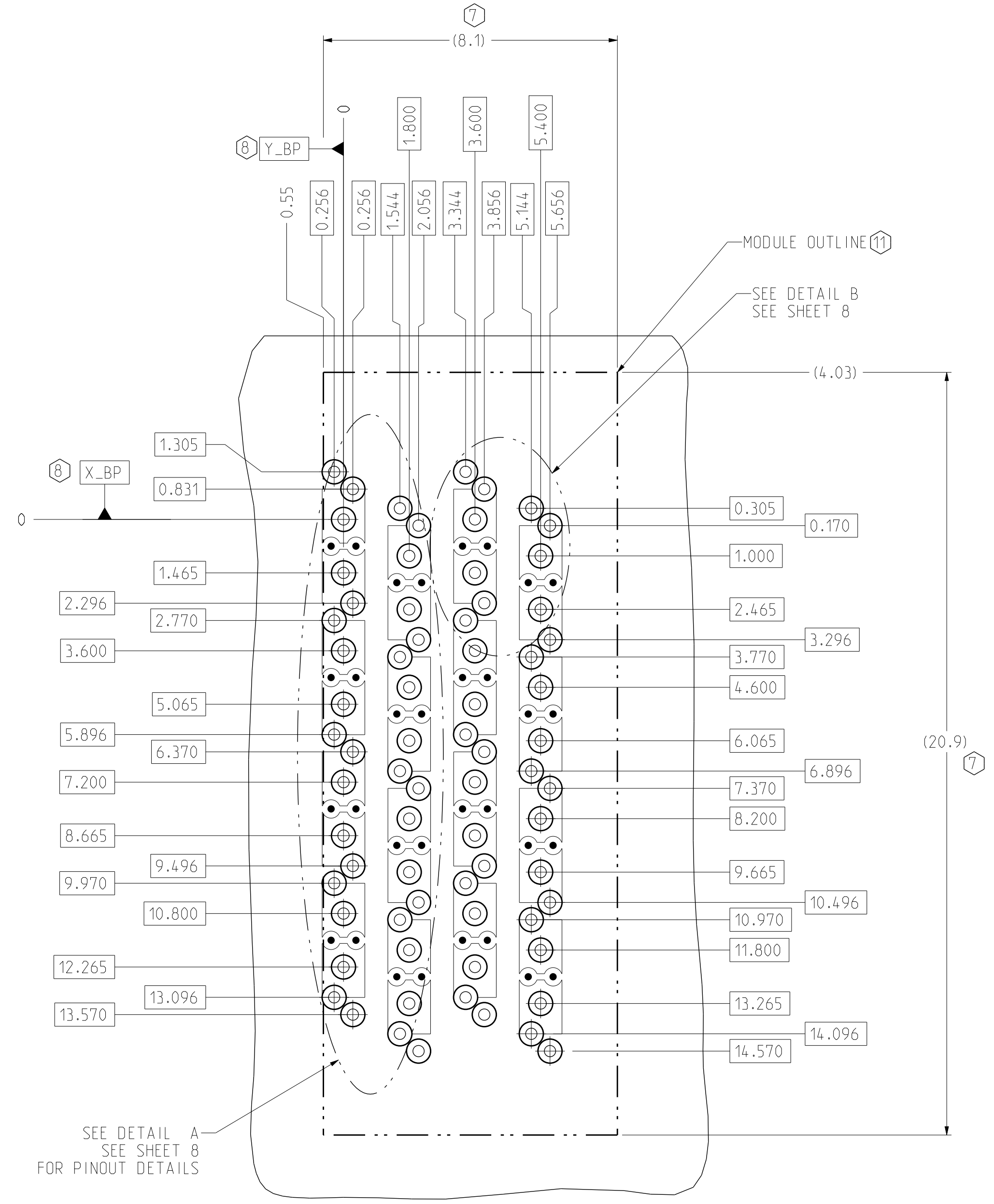

BP HOLE PATTERN  
COMPONENT SIDE  
SCALE 10/1

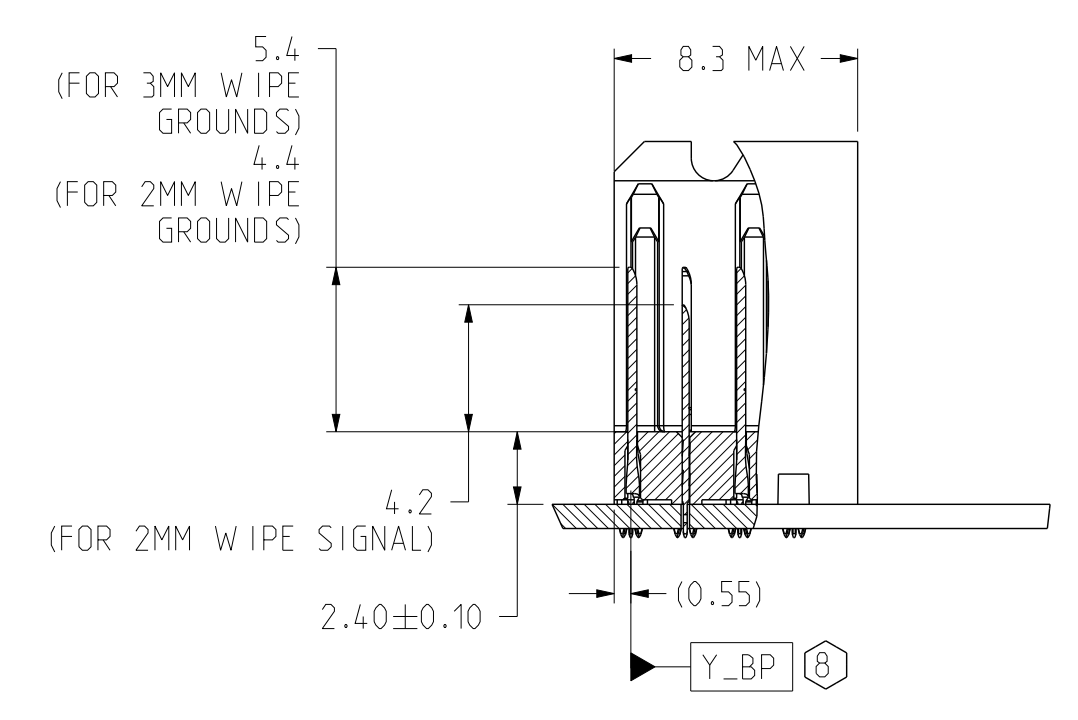

SECTION\_Z-Z

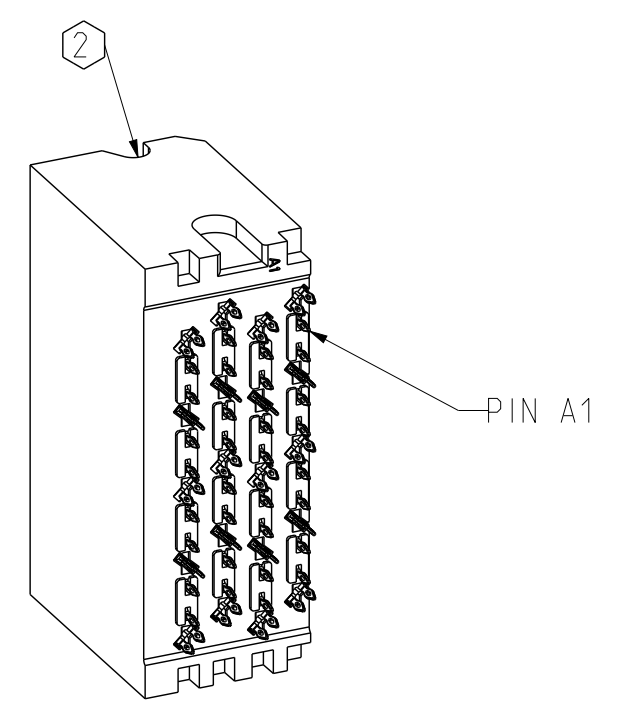
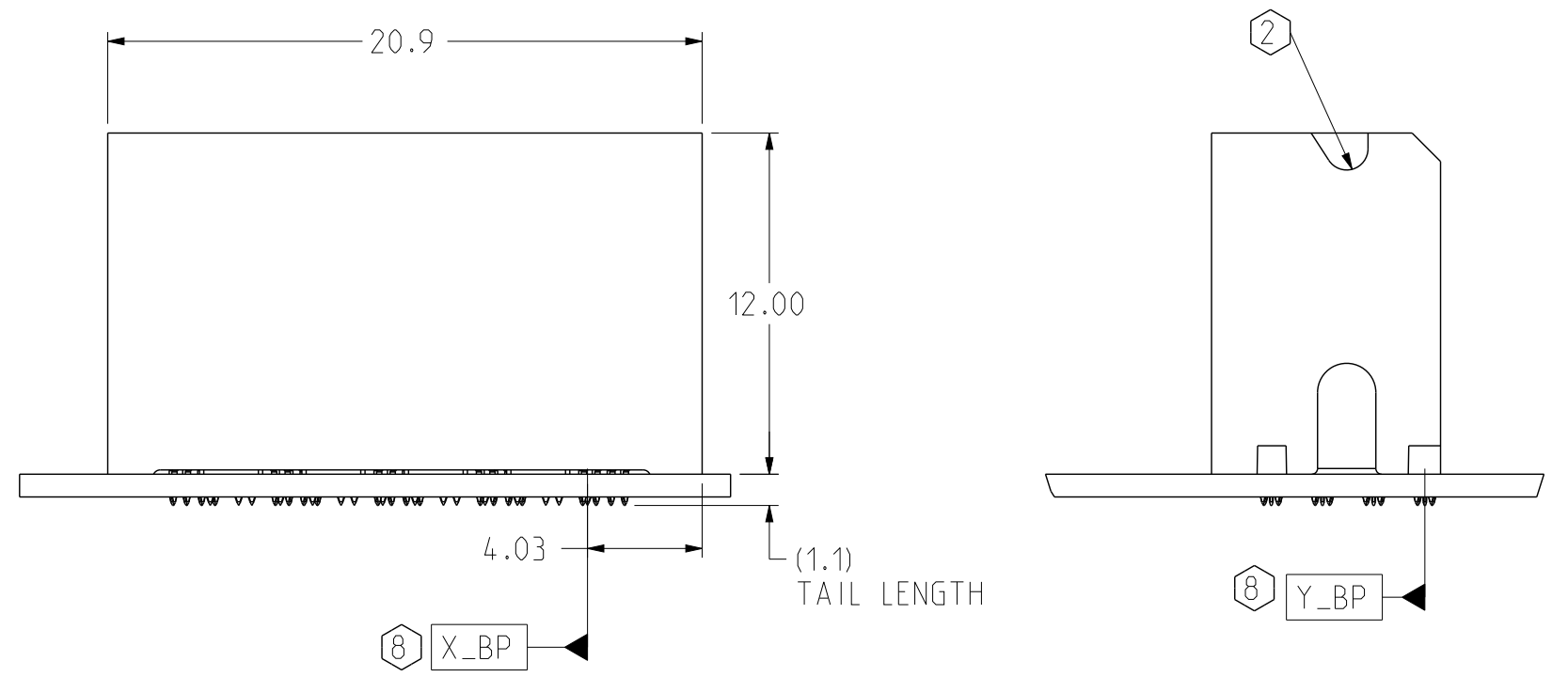

ISOMETRIC VIEW  
SCALE 3/1

RIGHT WALL BACKPLANE MODULE DIMENSION

TOLERANCES	DESIGN 11/07/2016 B.W ANG	<b>Amphenol TCS</b> A Division of Amphenol Corporation 200 Innovative Way, Nashua, NH 03062 603.879.3000	TITLE	BACKPLANE MODULES - VERTICAL MALE HEADER XCede HD2, 4 PAIR & POS, THICK WALL W/EXTRA GND
0.0 ±0.25	DRAWN 11/07/2016 HCL-NC		PART NO.	SEE P/N TREE SHEET 1
0.00 ±0.13	CHK 11/07/2016 B.W ANG		DRAWING NO.	C-972-401J-500
0.000 ± -	APVD 11/07/2016 B.W ANG		REV	G
ANGLES ± 3°	UNLESS OTHERWISE SPECIFIED DIMENSIONS ARE IN MM. DECIMAL MARKER IS A PERIOD.		ASSEM C972-401J-500_XG-HD2	0.2
			DRAWING C972-401J-500_XG-HD2	0.11
			SIZE D	SCALE 1/1
				SHEET 4 OF 9

INTERPRET PER ASME Y14.5M  
CODE IDENT 31413

CUSTOMER USE  
DRAWING

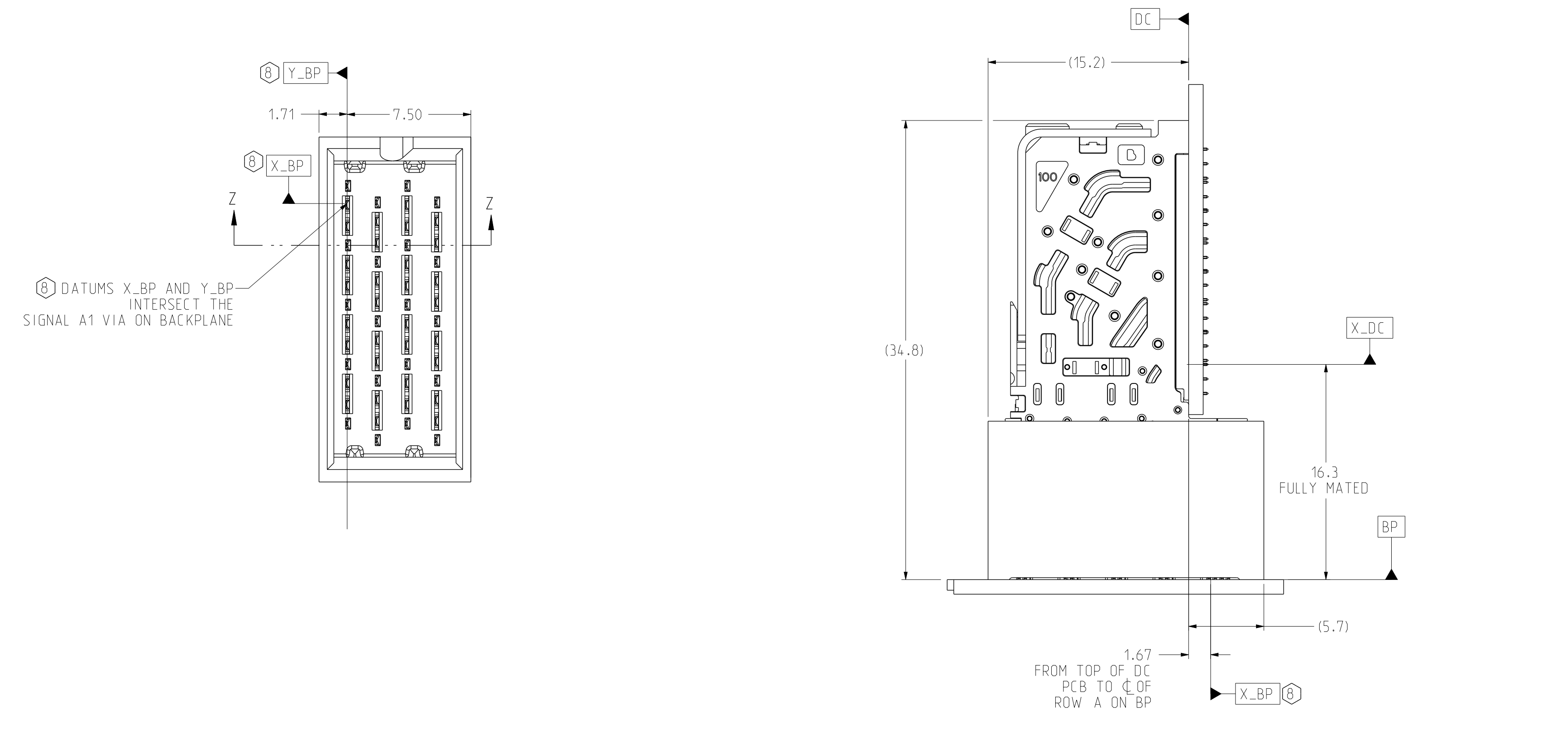

CONNECTOR REFERENCE  
SCALE 4/1

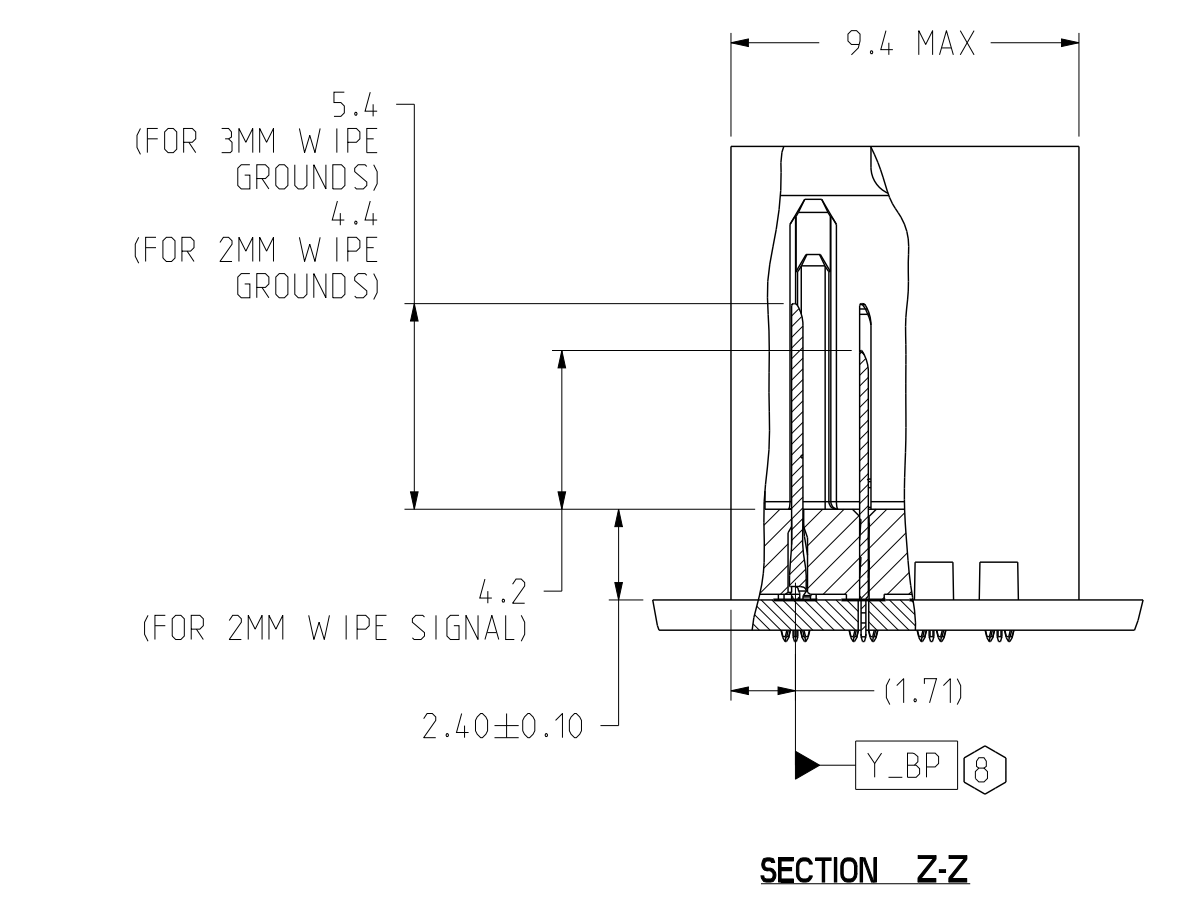

SECTION Z-Z

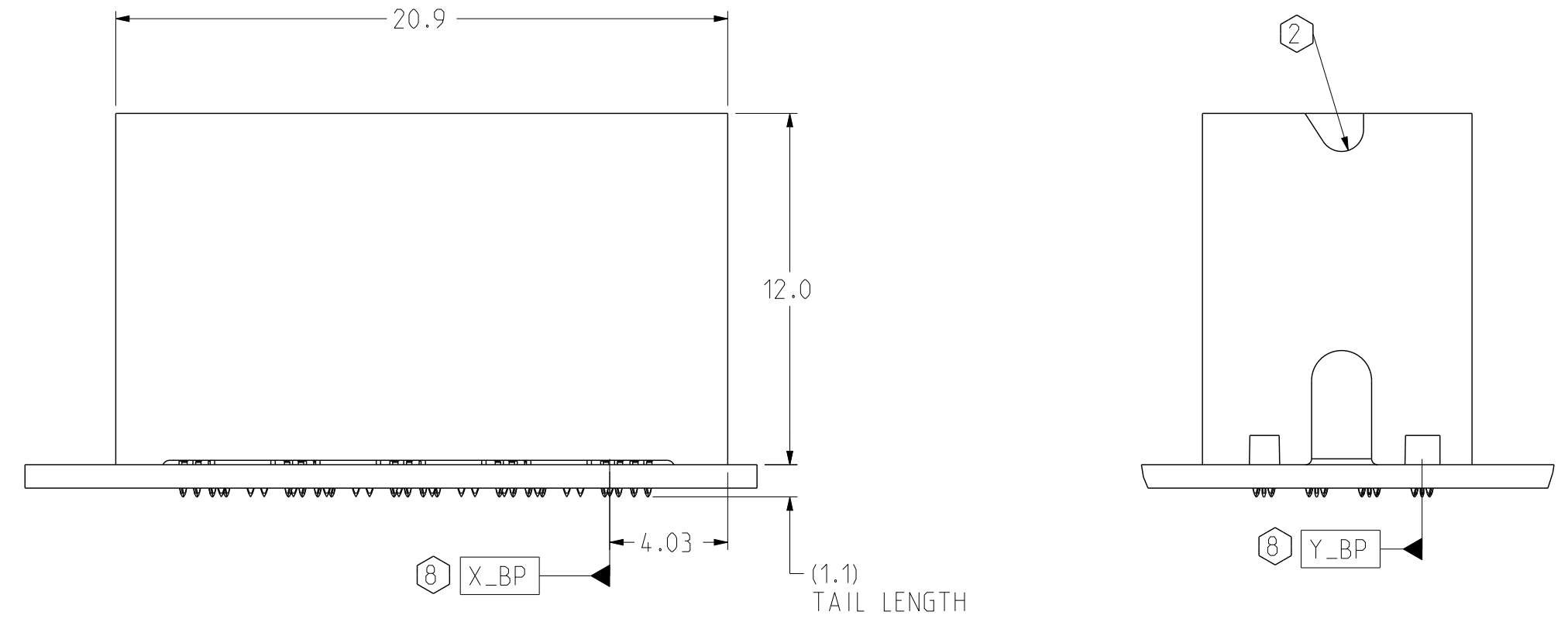

ISOMETRIC VIEW  
SCALE 3/1

TWO WALL BACKPLANE MODULE DIMENSION

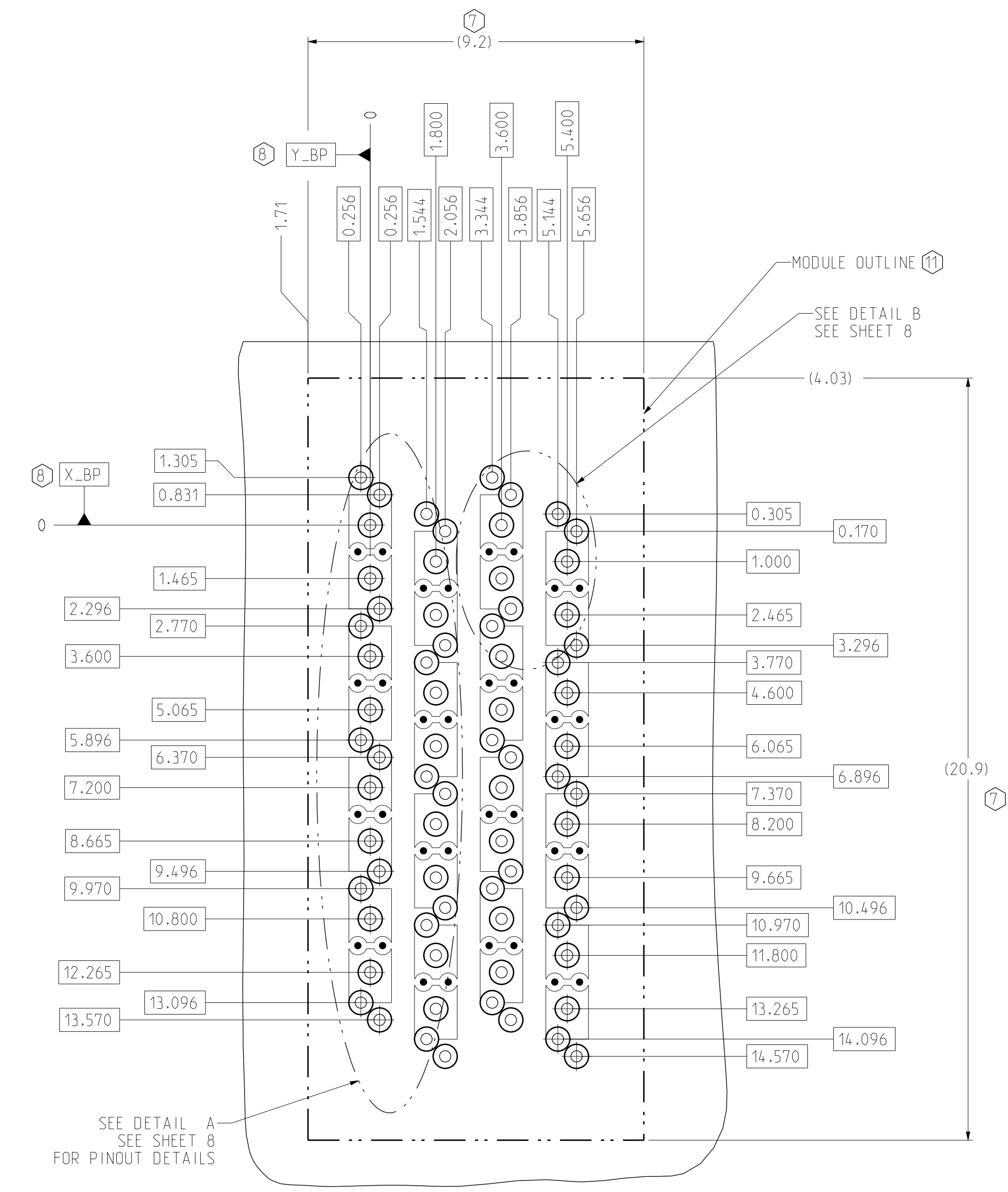

TWO WALL BACKPLANE FOOTPRINT

BP HOLE PATTERN  
COMPONENT SIDE  
SCALE 10/1

TOLERANCES		DESIGN 11/07/2016	B.W ANG		<b>Amphenol TCS</b> A Division of Amphenol Corporation 200 Innovative Way, Nashua, NH 03062 603.879.3000 TITLE BACKPLANE MODULES, VERTICAL MALE HEADER XCede HD2, 4 PAIR 4 POS, THICK WALL W/EXTRA GND PART NO. SEE P/N TREE SHEET 1 DRAWING NO. C-972-401J-500 ASSEM C972-401J-500_XG-HD2 0.2 DRAWING C972-401J-500_XG-HD2 0.11 SIZE D SCALE 1/1 SHEET 5 OF 9
0.0	±0.25	DRAWN 11/07/2016	HCL-NC		
0.00	±0.13	CHK 11/07/2016	B.W ANG		
0.000	± -	APVD 11/07/2016	B.W ANG		
ANGLES ± 3°		UNLESS OTHERWISE SPECIFIED DIMENSIONS ARE IN MM, DECIMAL MARKER IS A PERIOD			REV N/A

INTERPRET PER ASME Y14.5M  
CODE IDENT 31413

CUSTOMER USE  
DRAWING

8

7

6

5

4

3

8

7

6

5

4

3

2

1

ZONE	REV	ECN NUMBER	DESCRIPTION	BY	DATE	APPROVED
			SEE SHEET 1			

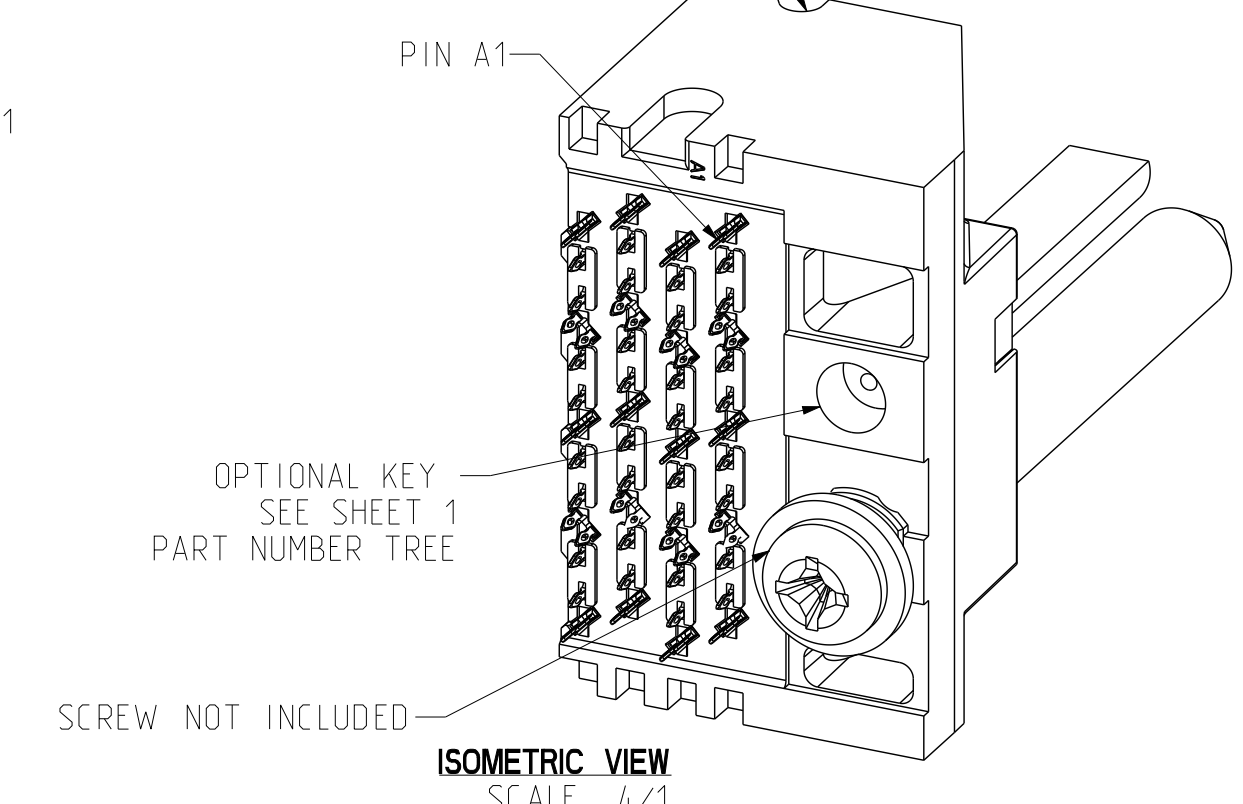
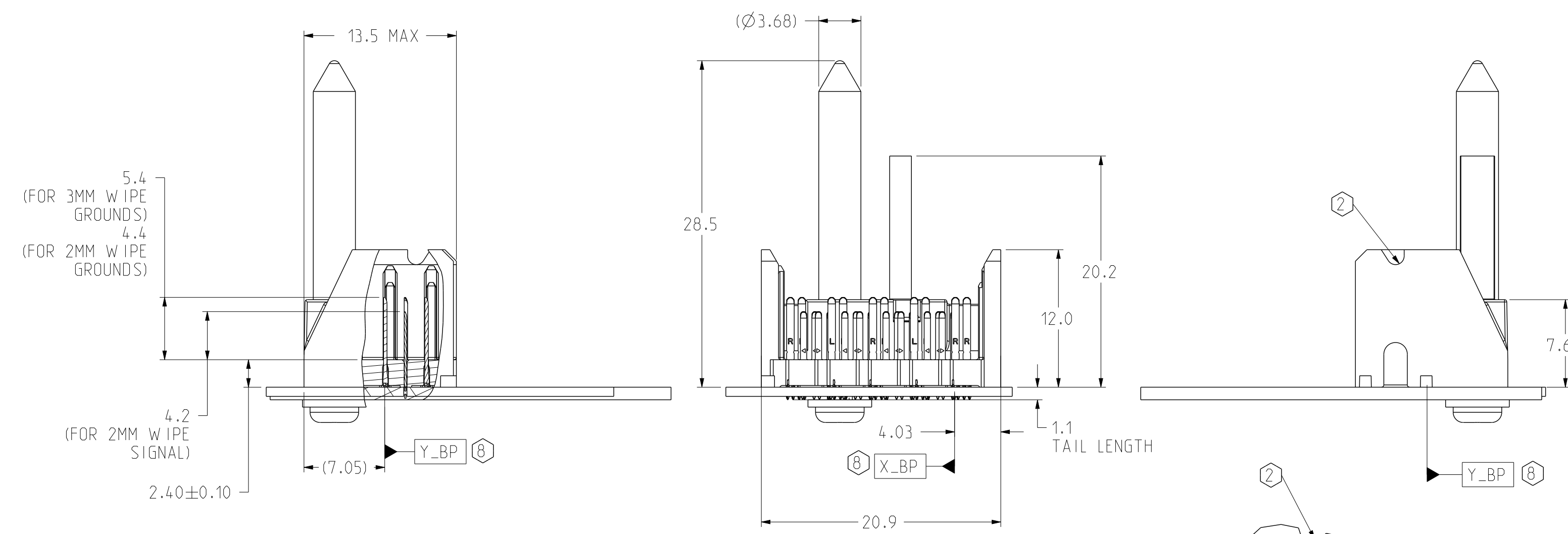
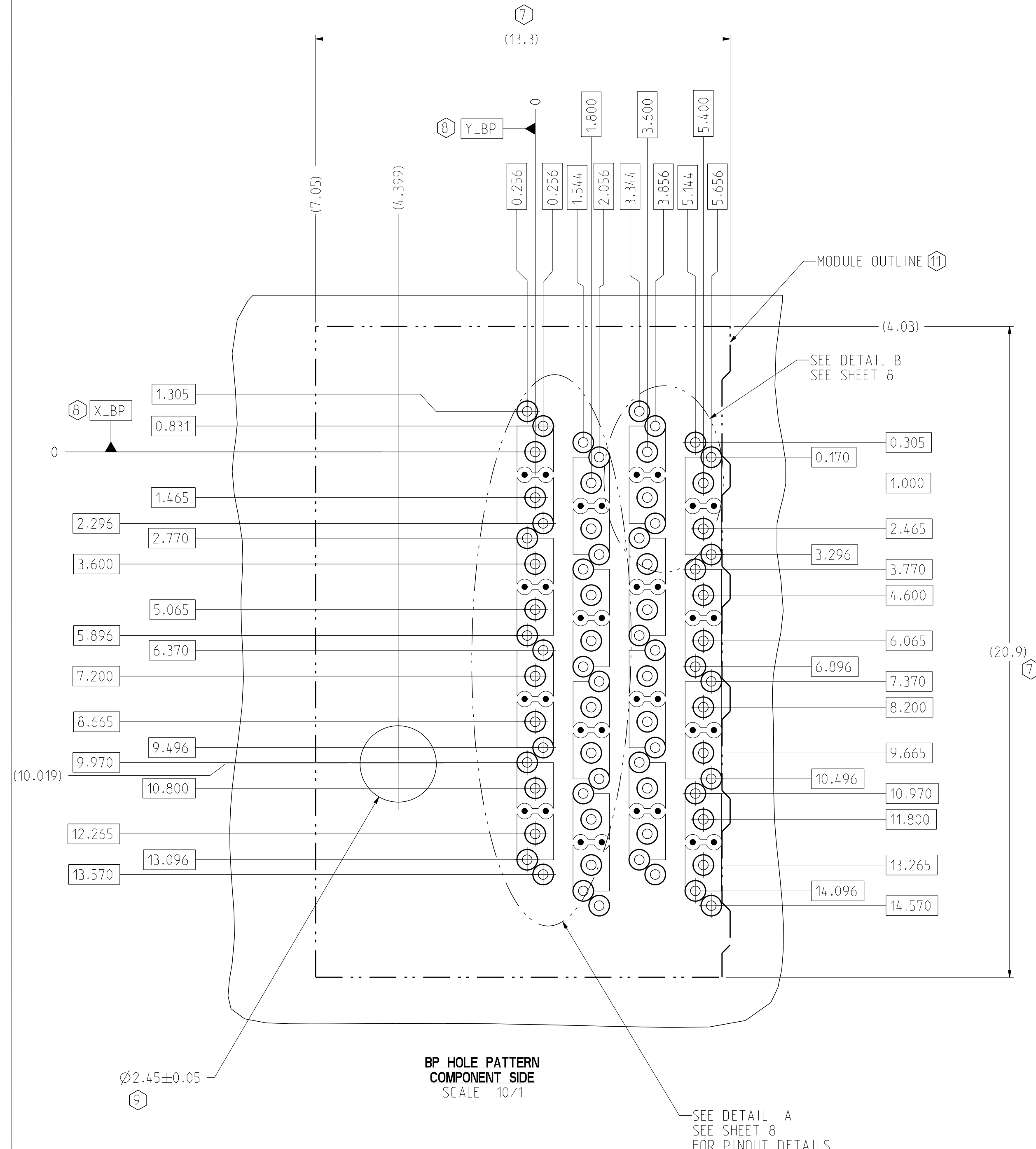
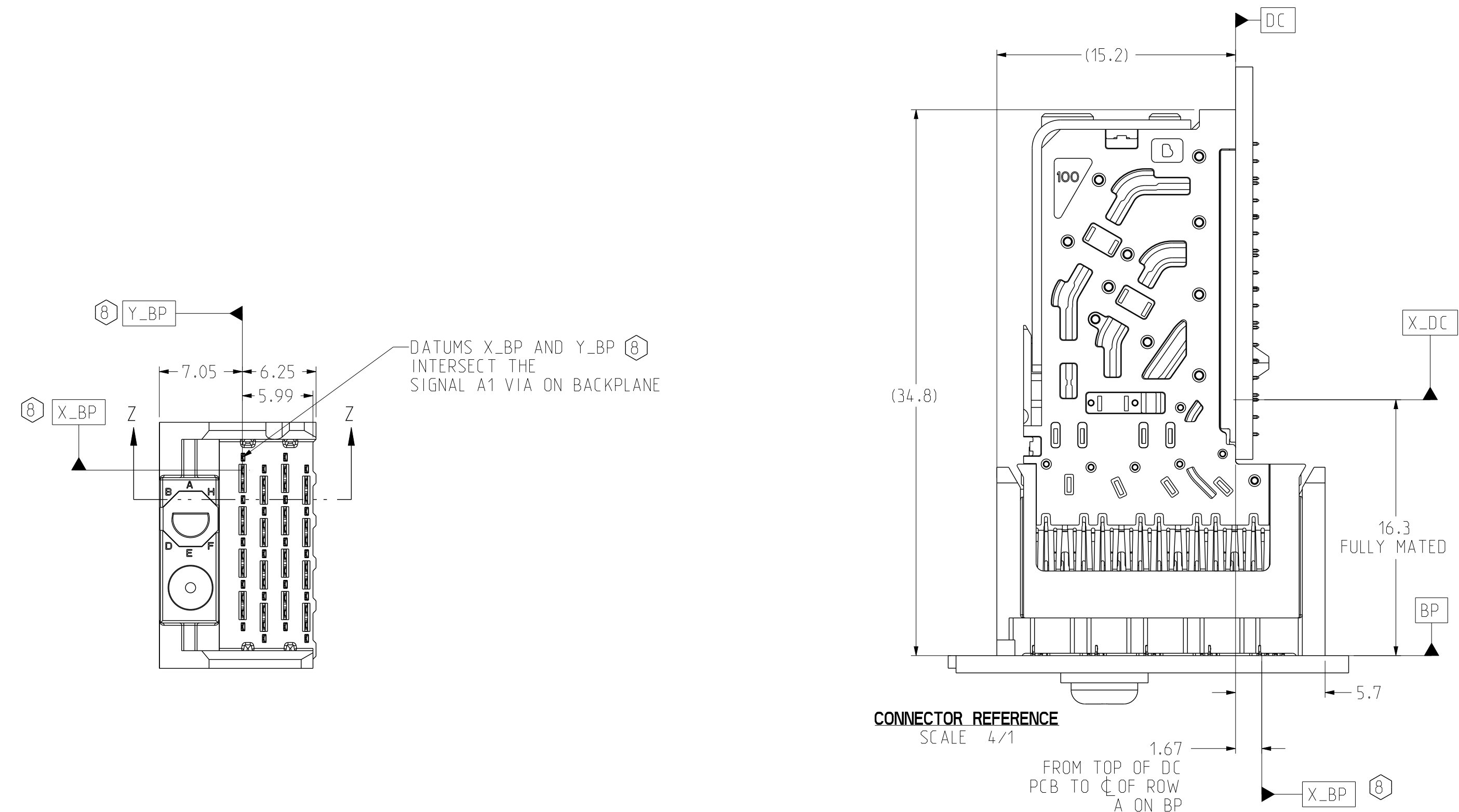

**LEFT POLARIZING/GUIDE BACKPLANE MODULE DIMENSION**

TOLERANCES		DESIGN 11/07/2016	B.W ANG	<b>Amphenol TCS</b> A Division of Amphenol Corporation 200 Innovative Way, Nashua, NH 03062 603.879.3000
0.0	±0.25	DRAWN 11/07/2016	HCL-NC	
0.00	±0.13	CHK 11/07/2016	B.W ANG	TITLE BACKPLANE MODULES - VERTICAL MALE HEADER XCede HD2. 4 PAIR & POS. THICK WALL W/EXTRA GND
0.000	± -	APVD 11/07/2016	B.W ANG	PART NO. SEE P/N TREE SHEET 1
ANGLES ± 3°				REV N/A
UNLESS OTHERWISE SPECIFIED DIMENSIONS ARE IN MM. DECIMAL MARKER IS A PERIOD.				DRAWING NO. C-972-401J-500
INTERPRET PER ASME Y14.5M CODE IDENT 31413				ASSEM C972-401J-500_XG-HD2 0.2 DRAWING C972-401J-500_XG-HD2 0.11
CUSTOMER USE DRAWING				SIZE D SCALE 1/1 SHEET 6 OF 9

ZONE	REV	ECN NUMBER	DESCRIPTION	BY	DATE	APPROVED
			SEE SHEET 1			

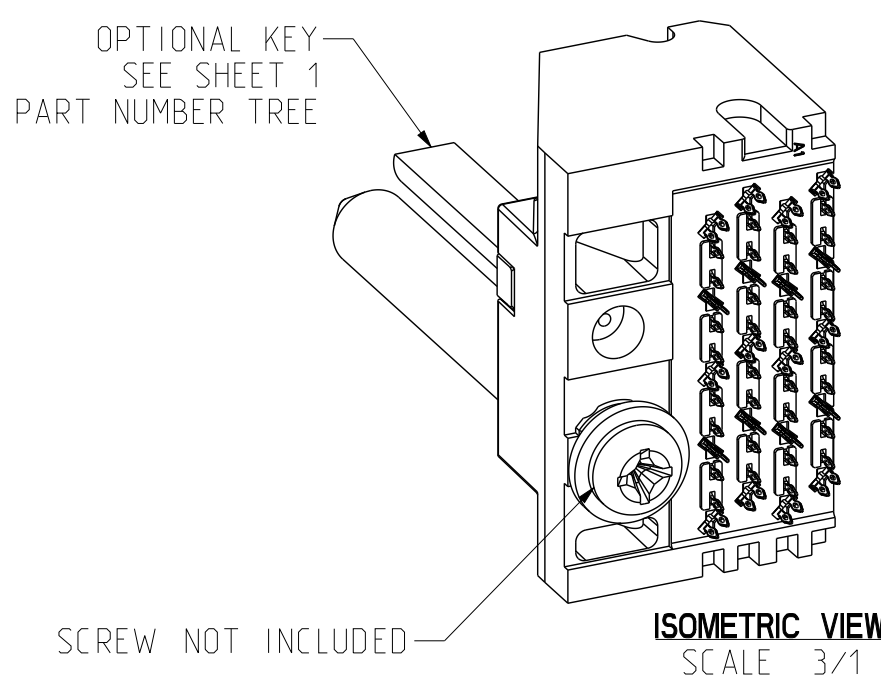
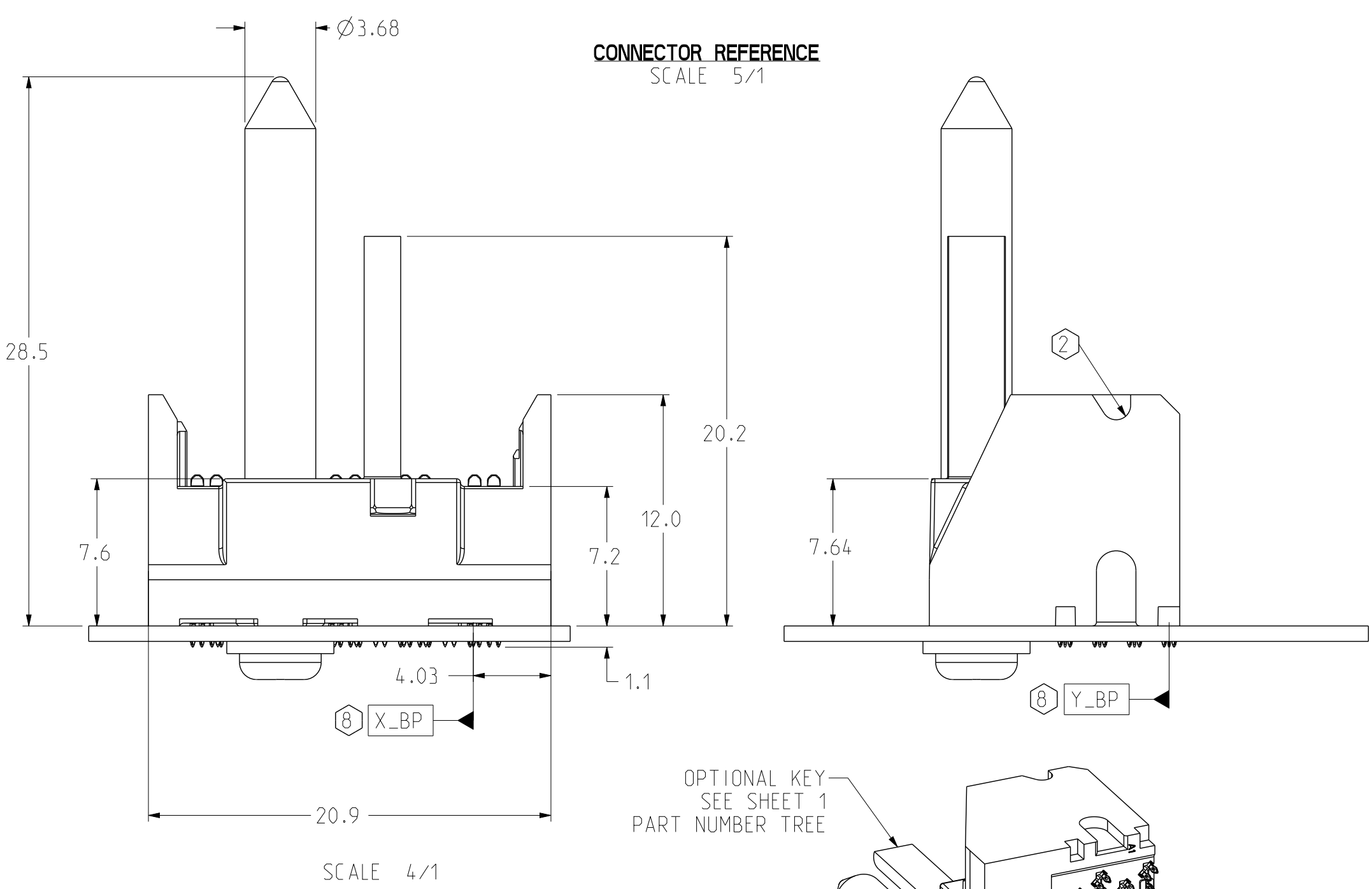
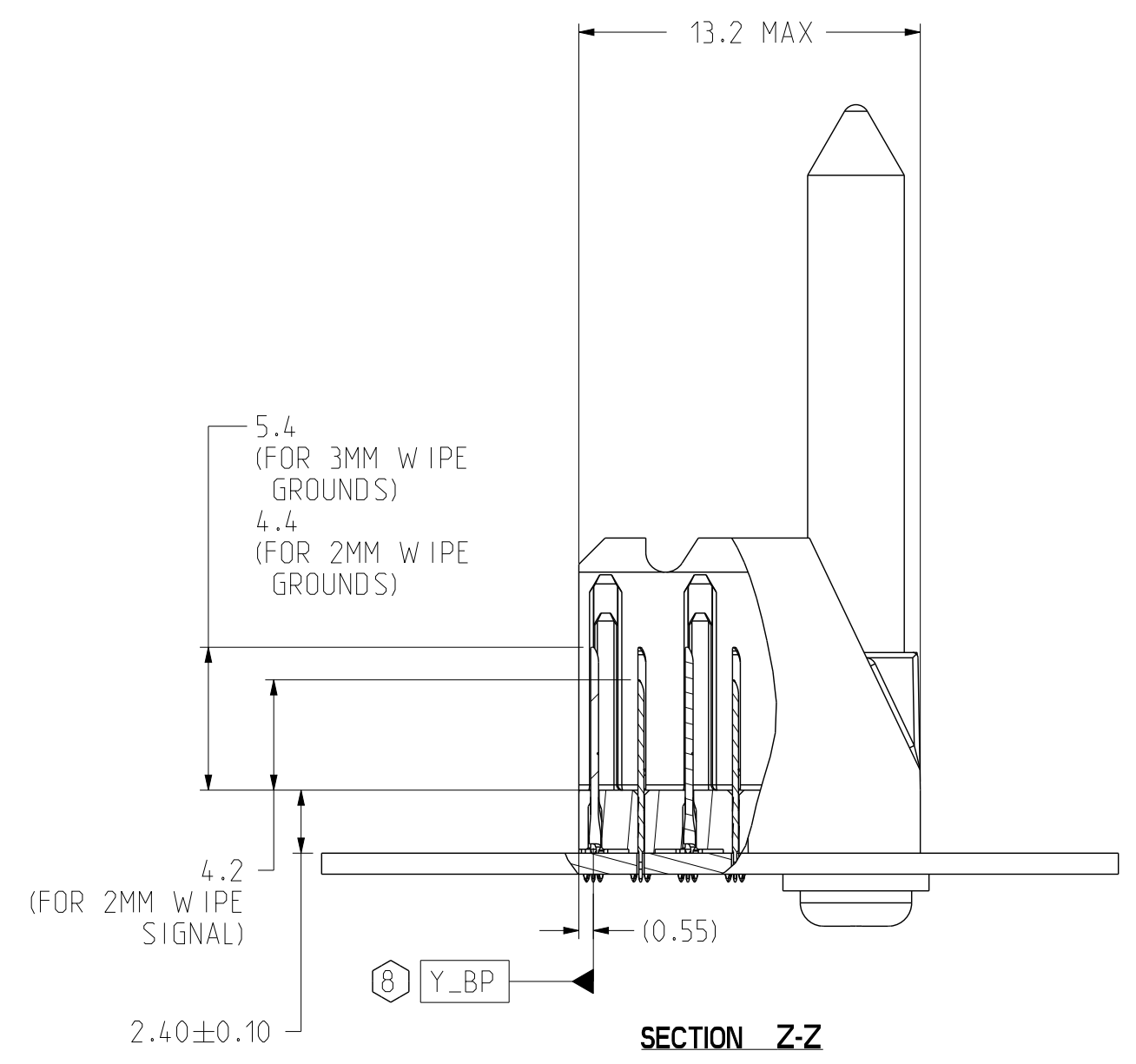
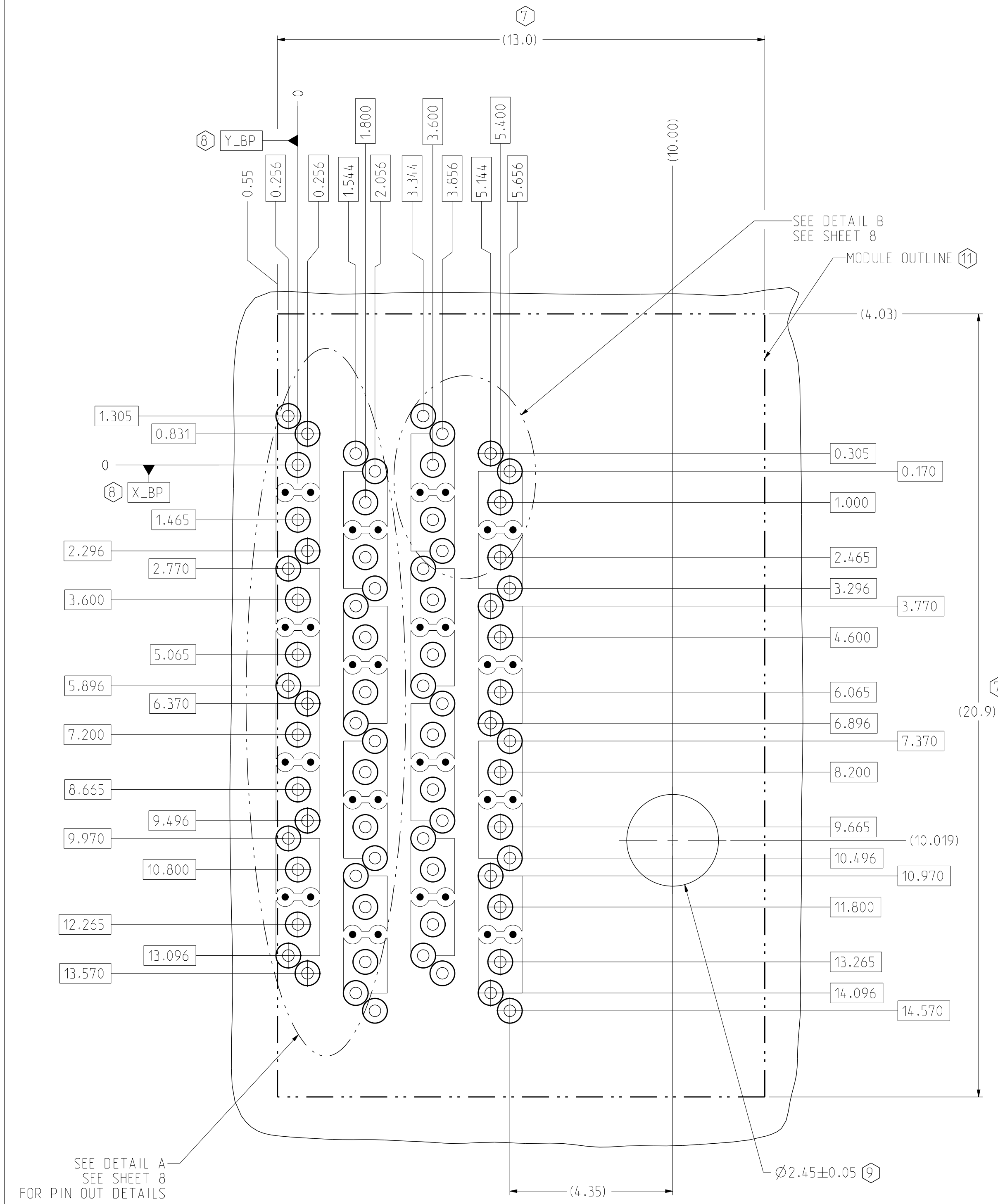
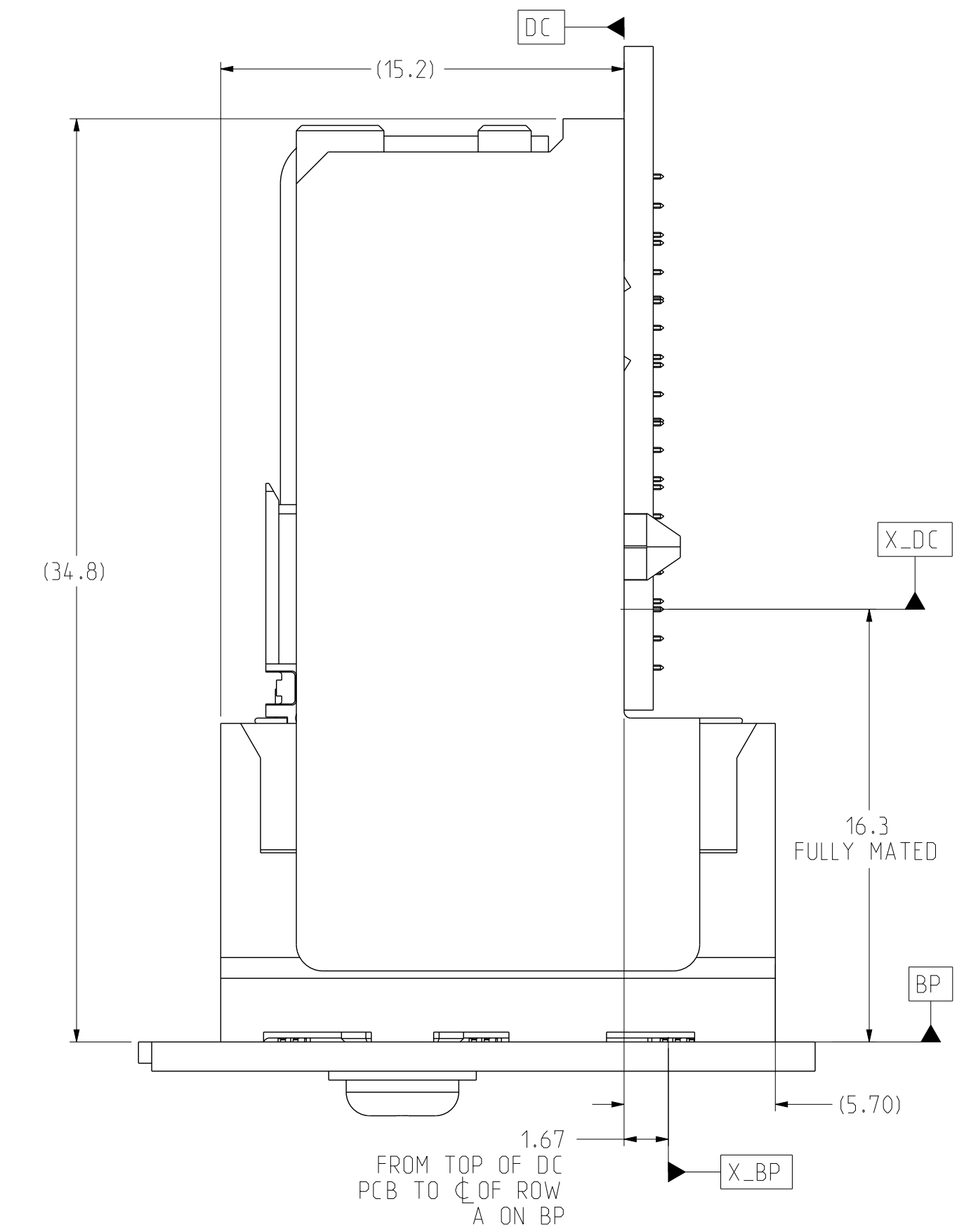
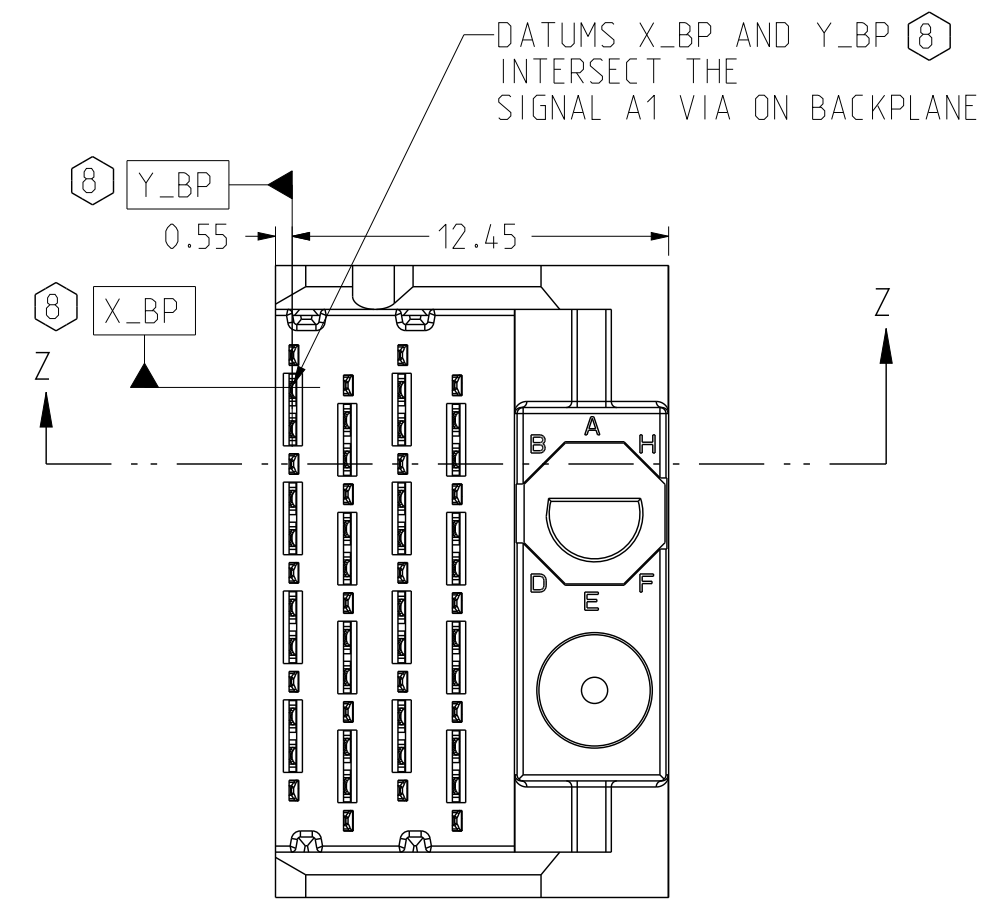

**RIGHT POLARIZING/GUIDE BACKPLANE MODULE DIMENSION**

TOLERANCES	DESIGN 11/07/2016 B.W ANG	<b>Amphenol TCS</b> A Division of Amphenol Corporation 200 Innovative Way, Nashua, NH 03082 603.879.3000	TITLE	BACKPLANE MODULES - VERTICAL MALE HEADER
0.0 ±0.25	DRAWN 11/07/2016 HCL-NC		XCode	HD2, 4 PAIR & POS, THICK WALL W/EXTRA GND
0.00 ±0.13	CHK 11/07/2016 B.W ANG		PART NO.	SEE P/N TREE SHEET 1
0.000 ± -	APVD 11/07/2016 B.W ANG		REV	N/A
ANGLES ± 3°	UNLESS OTHERWISE SPECIFIED DIMENSIONS ARE IN MM. DECIMAL MARKER IS A PERIOD		DRAWING NO.	C-972-401J-500
			ASSEMBLY	C972-401J-500_XG-HD2 0.2
			DRAWING	C972-401J-500_XG-HD2 0.11
			SIZE	D
			SCALE	1/1
			SHEET	7 OF 9

INTERPRET PER ASME Y14.5M  
CODE IDENT 31413

CUSTOMER USE DRAWING

ZONE	REV	ECN NUMBER	DESCRIPTION	BY	DATE	APPROVED
			SEE SHEET 1			

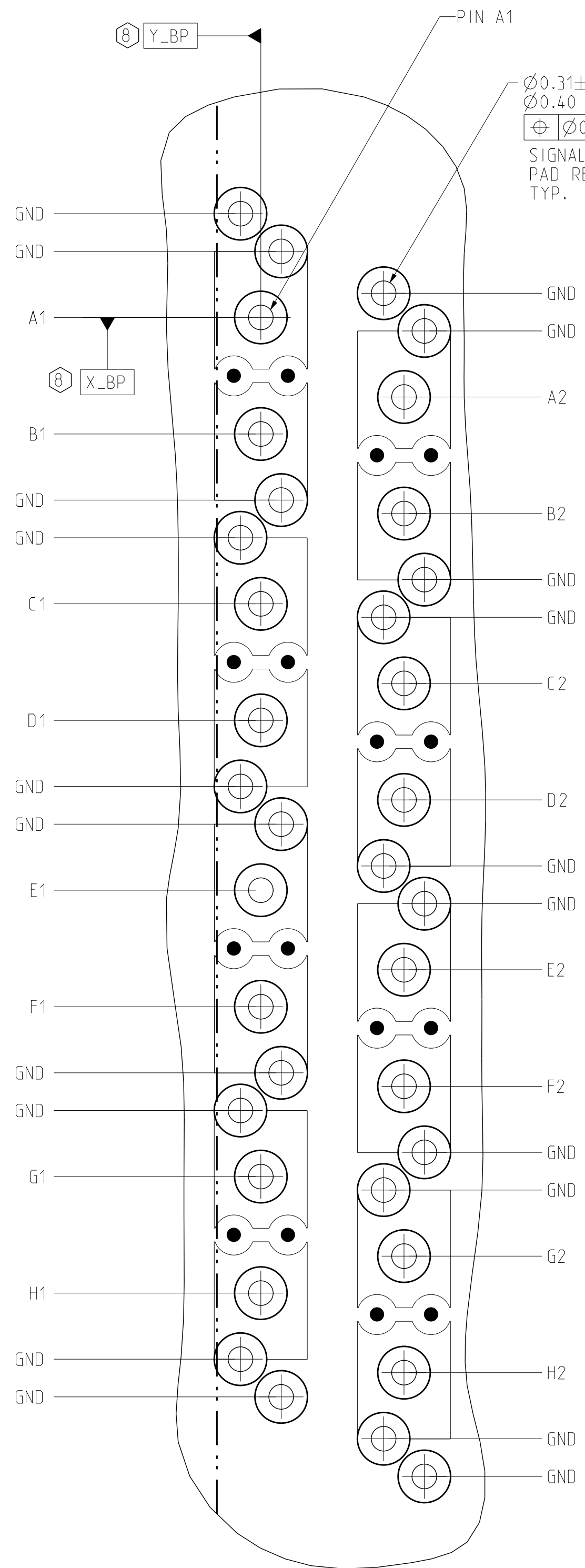

**DETAIL A**  
PINOUT DETAILS  
SCALE 20/1

$\varnothing 0.31 \pm 0.05$  PTH  $\varnothing 0.40$  [.0157"] DRILL  
 $\varnothing 0.10$  X\_BP Y\_BP  
 SIGNAL AND GROUND PIN HOLES  
 PAD REQUIRED SEE NOTE  
 TYP.

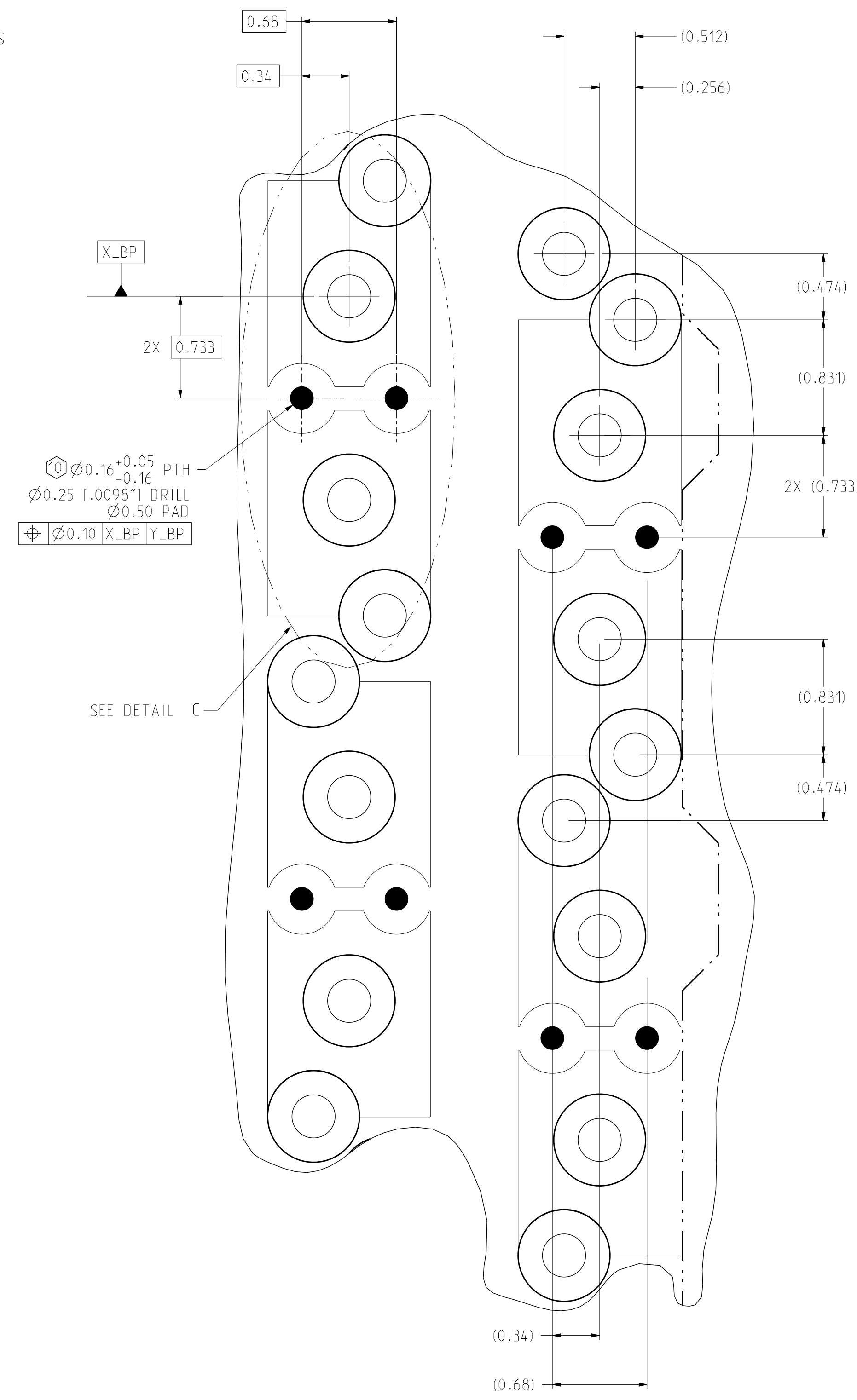

**DETAIL B**  
SHADOW VIAS (BETWEEN SIGNALS)  
TYPICAL LAYOUT  
SCALE 40/1

$\varnothing 0.16 \pm 0.05$  PTH  
 $\varnothing 0.25$  [.0098"] DRILL  
 $\varnothing 0.50$  PAD  
 $\varnothing 0.10$  X\_BP Y\_BP

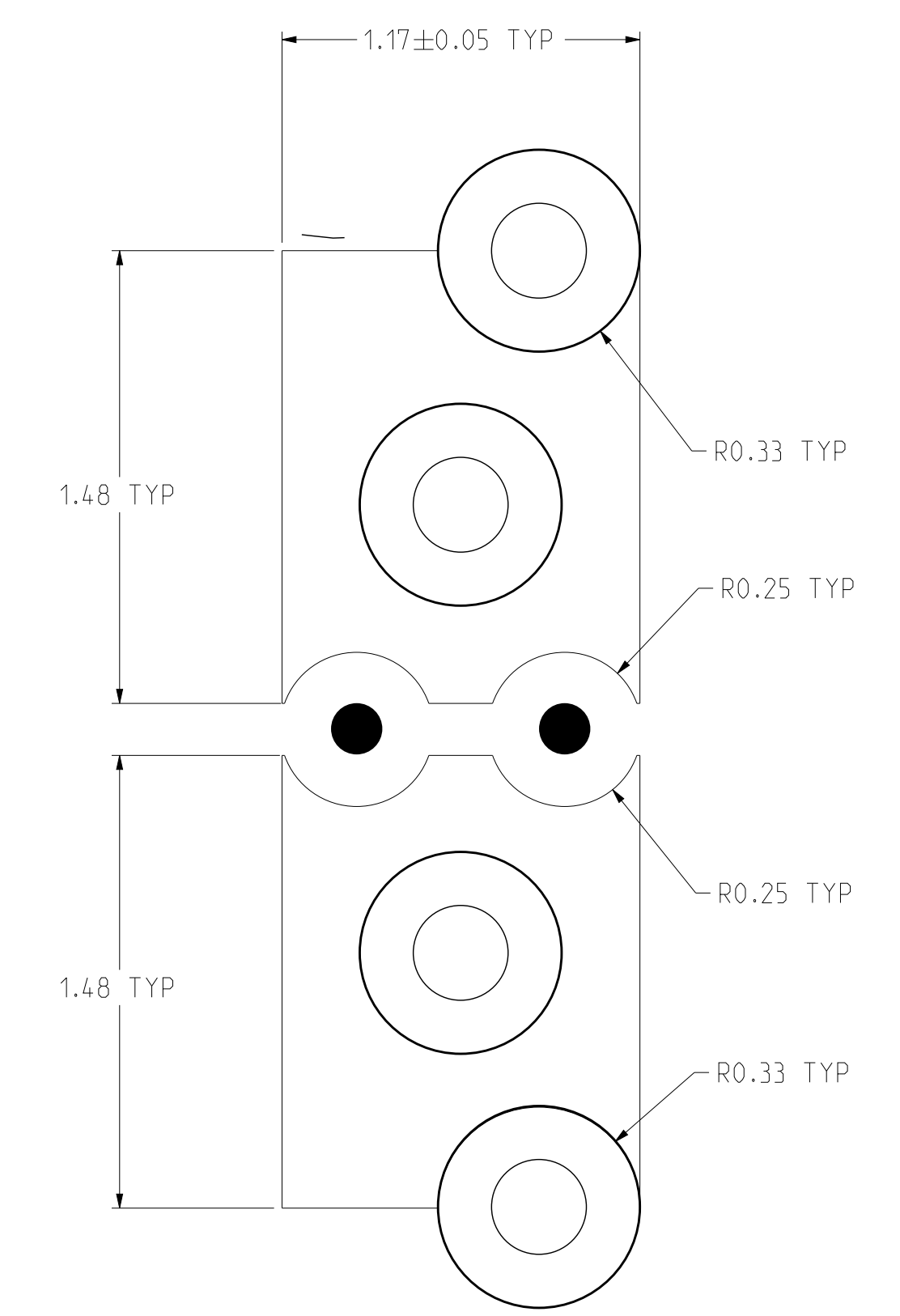

**DETAIL C**  
ANTI PAD DETAILS  
GROUND AND SHADOW VIAS CAN BE CONNECTED AS  
ONE CONTINUOUS SURFACE PAD  
SCALE 50/1

TOLERANCES	DESIGN 11/07/2016 B.W ANG	<b>Amphenol TCS</b> A Division of Amphenol Corporation 200 Innovative Way, Nashua, NH 03062 603.879.3000	TITLE	BACKPLANE MODULES, VERTICAL MALE HEADER XCede HD2, 4 PAIR 4 POS, THICK WALL W/EXTRA GND
0.0 ±0.25	DRAWN 11/07/2016 HCL-NC		PART NO.	SEE P/N TREE SHEET 1
0.00 ±0.13	CHK 11/07/2016 B.W ANG		REV	N/A
0.000 ± -	APVD 11/07/2016 B.W ANG		DRAWING NO.	C-972-401J-500
ANGLES ± 3°	UNLESS OTHERWISE SPECIFIED DIMENSIONS ARE IN MM. DECIMAL MARKER IS A PERIOD		ASSEM C972-401J-500_XG-HD2	0.2
			DRAWING C972-401J-500_XG-HD2	0.11
			SIZE D	SCALE 1/1
				SHEET 8 OF 9

INTERPRET PER ASME Y14.5M  
 CODE IDENT 31413

CUSTOMER USE  
 DRAWING



ZONE	REV	ECN NUMBER	DESCRIPTION	BY	DATE	APPROVED
			SEE SHEET 1			

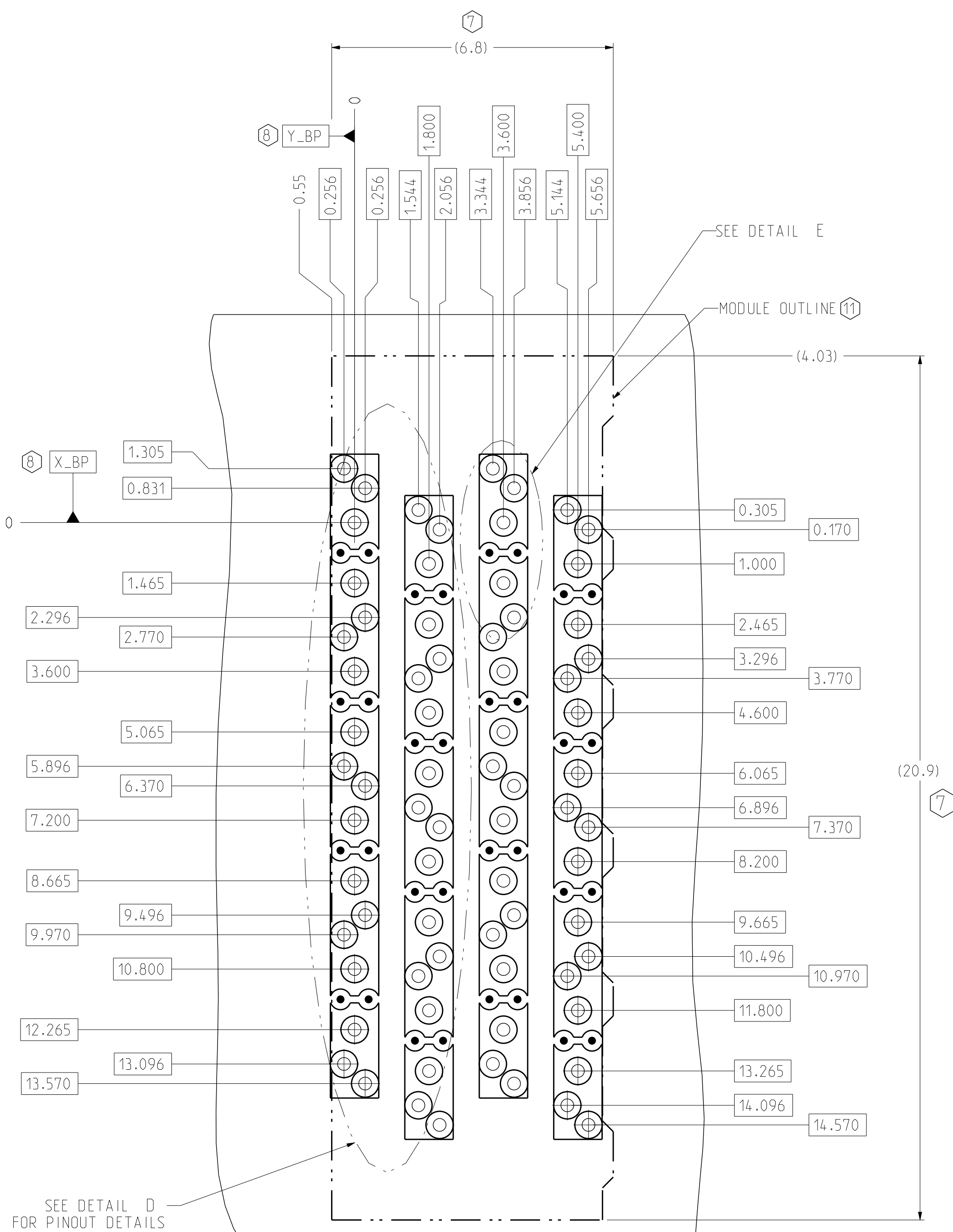

SE MODULE  
BP HOLE PATTERN  
COMPONENT SIDE  
SCALE 12/1

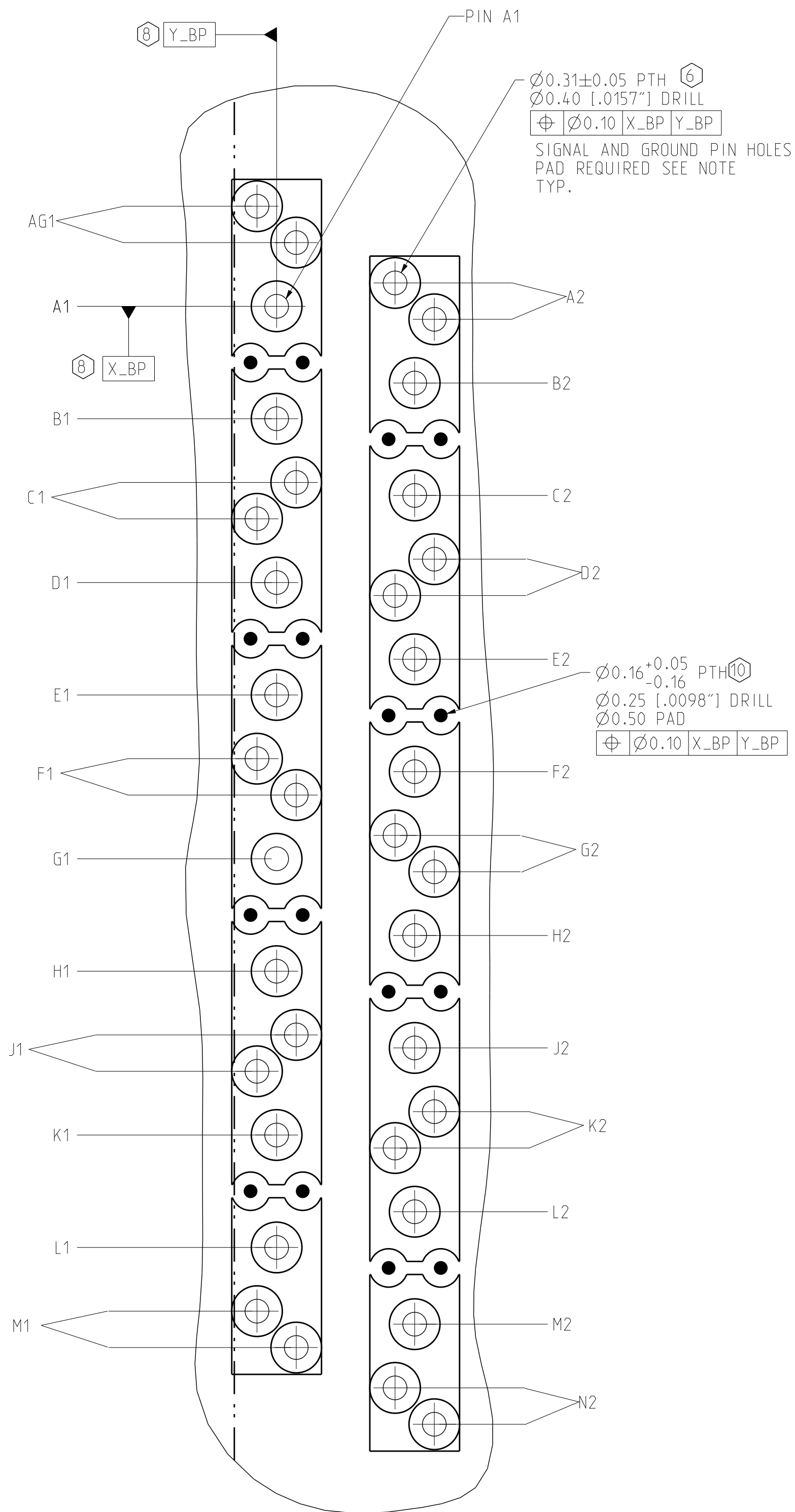

DETAIL D  
SE PINOUT DETAILS  
SCALE 20/1

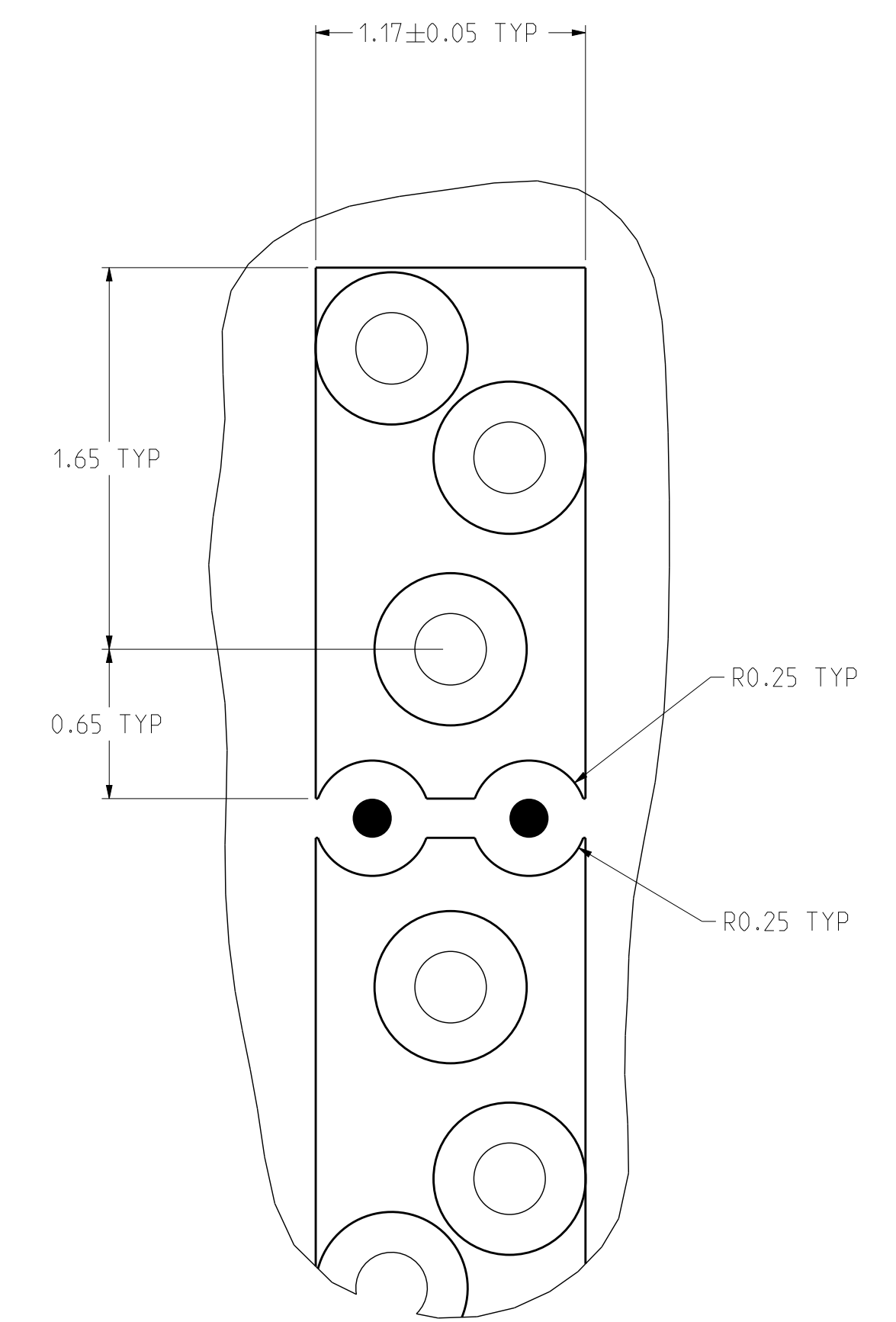

DETAIL E  
SE ANTIPAD DETAILS  
GROUND AND SHADOW VIAS CAN BE CONNECTED AS  
ONE CONTINUOUS SURFACE PAD  
SCALE 40/1

TOLERANCES	DESIGN 11/07/2016 B.W ANG	<b>Amphenol TCS</b> A Division of Amphenol Corporation 200 Innovative Way, Nashua, NH 03082 603.879.3000	TITLE	BACKPLANE MODULES - VERTICAL MALE HEADER
0.0 ±0.25	DRAWN 11/07/2016 HCL-NC		XCode	HD2, 4 PAIR & POS, THICK WALL W/EXTRA GND
0.00 ±0.13	CHK 11/07/2016 B.W ANG		PART NO.	SEE P/N TREE SHEET 1
0.000 ± -	APVD 11/07/2016 B.W ANG		DRAWING NO.	C-972-401J-500
ANGLES ± 3°	UNLESS OTHERWISE SPECIFIED DIMENSIONS ARE IN MM. DECIMAL MARKER IS A PERIOD.		ASSEM	C972-401J-500_XG-HD2 0.2
			DRAWING	C972-401J-500_XG-HD2 0.11
			SIZE	D
			SCALE	1/1
			SHEET	9 OF 9

INTERPRET PER ASME Y14.5M  
CODE IDENT 31413

CUSTOMER USE  
DRAWING