

REV	ECN	DESCRIPTION	BY	DATE	APPROVED
A	JLIU-22111521	RELEASE TO PRODUCTION	J.LIU	11/28/2022	J.LIU

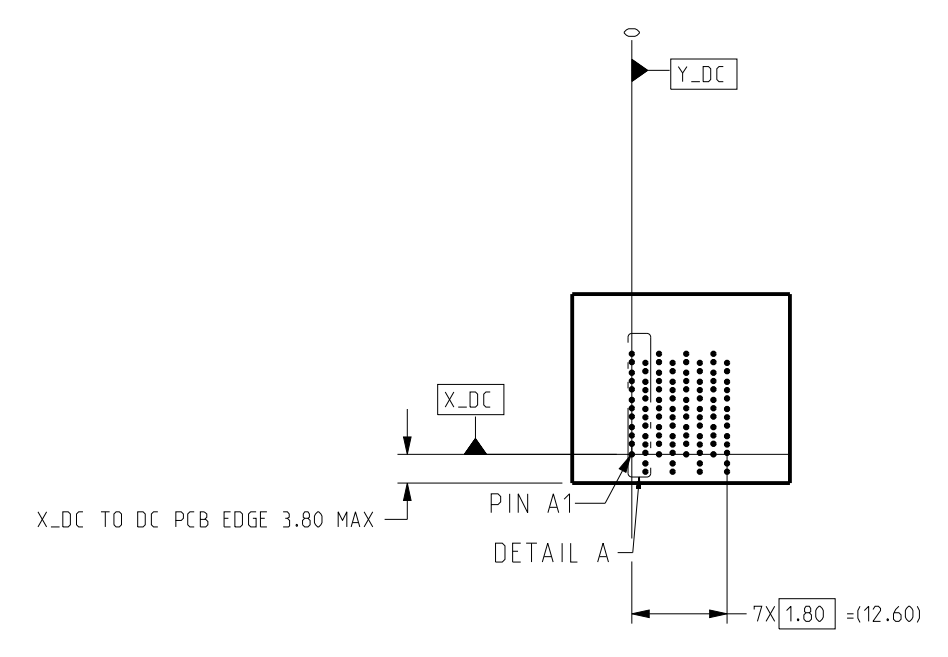

FRONT VIEW - DC HOLE PATTERN ONLY . CONNECTOR SIDE REFERENCED FROM LEFT MOST SIGNAL COLUMN ; ALL DIMENSIONS BASIC

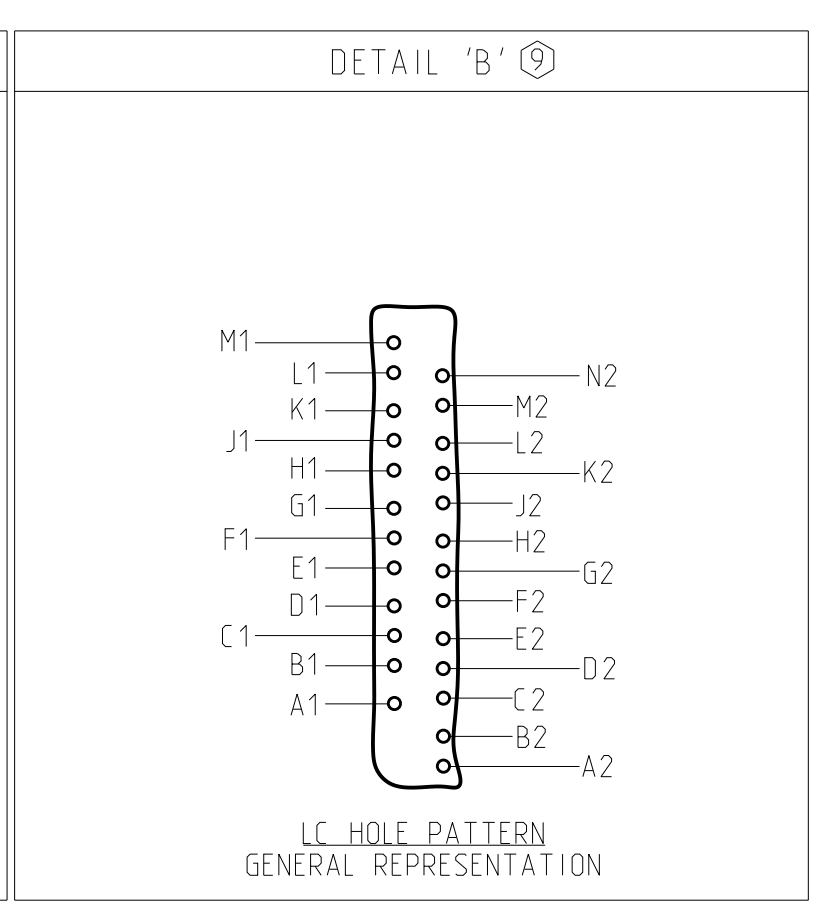
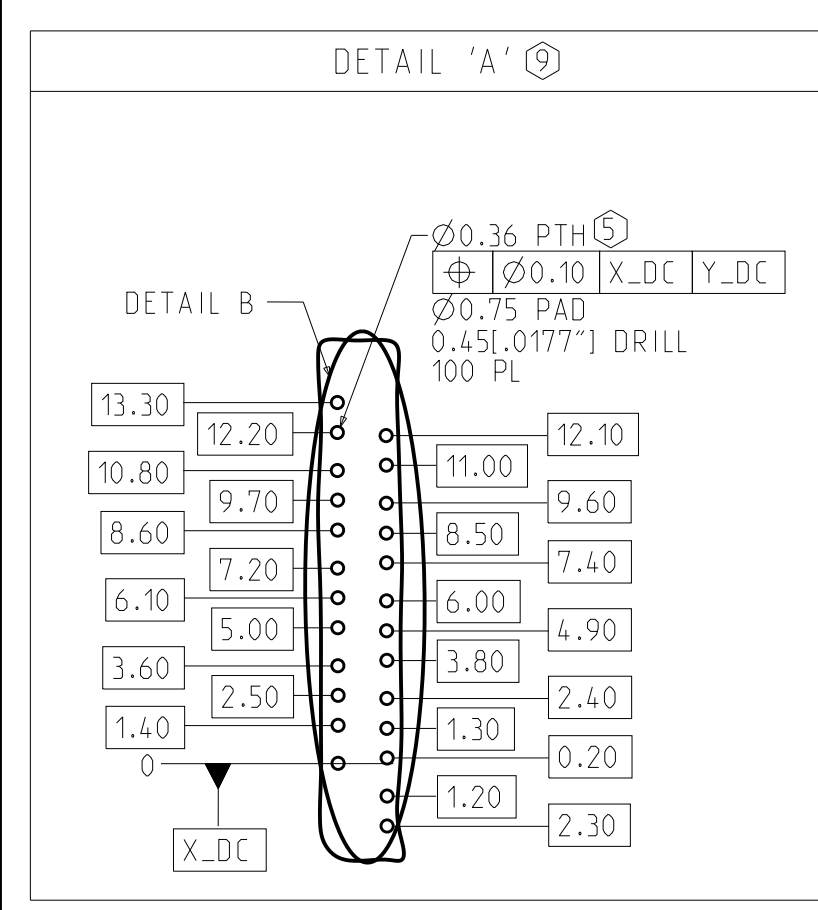
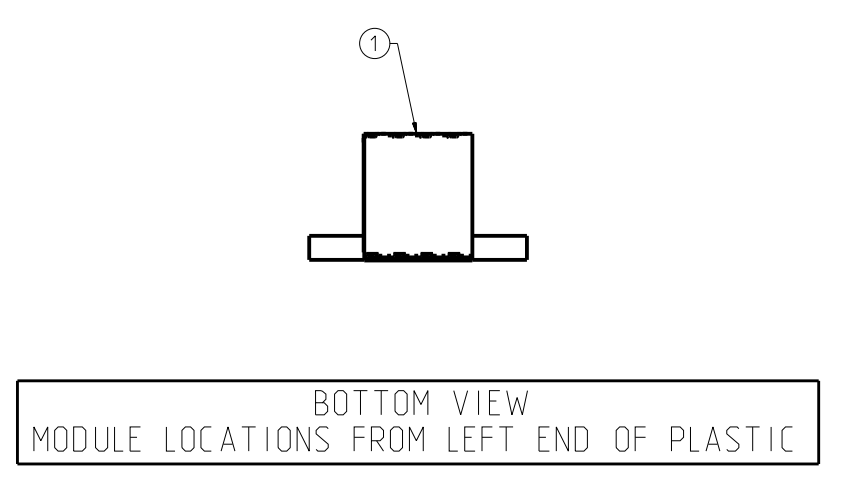
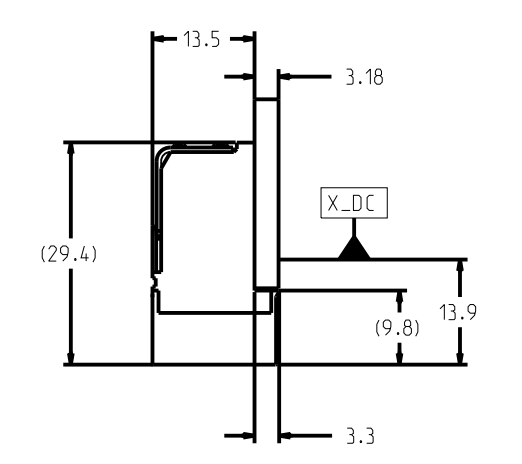
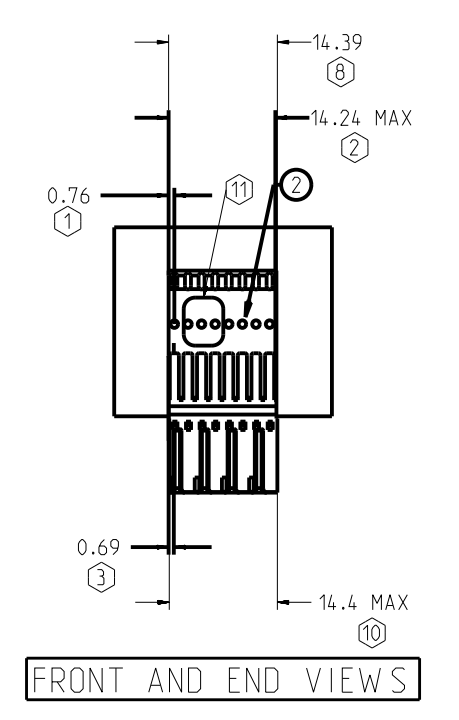

BOTTOM VIEW MODULE LOCATIONS FROM LEFT END OF PLASTIC

ITEM	PART NUMBER	DESCRIPTION	QTY
1	922-421G-D3H	XCede HD 4PAIR LC MOD w/ ORGANIZER, 8POS, 85OHMS, BIFURCATED, .0177" DRILL, NANO NI, STD GOLD	1
2	617-0450-014	XCede HD 4PAIR STIFFENER	1

NOTE: SEE FRONT VIEW FOR STIFFENER LENGTH.

NOTES:

- ① DISTANCE FROM FIRST STIFFENER PILOT HOLE TO LEFT END OF STIFFENER.
- ② TOTAL LENGTH OF STIFFENER.
- ③ DISTANCE FROM CENTERLINE OF 1ST COLUMN OF SIGNAL PLATED THRU HOLES TO LEFT EDGE OF STIFFENER.
- ④ MOUNTING SCREWS AND JOINER MODULES (IF PRESENT) TO BE BAGGED WITH EACH CONNECTOR ASSEMBLY.
- ⑤ STATED PAD SIZE MAY REQUIRE FILLETING. SEE TB-2237 FOR ROUTING, HOLE WALL PLATING THICKNESS AND FINISHED HOLE SIZE.
- ⑥ NA.
- ⑦ REFER TO TB-2235 FOR XCede HD PRODUCT SPECIFICATIONS.
- ⑧ OVERALL CONNECTOR LENGTH.
- ⑨ DETAIL VIEWS ARE NOT TO SCALE. DO NOT SCALE DRAWING.
- ⑩ FRONT HOUSING WIDTH. CONNECTORS CAN BE USED IN STACKABLE APPLICATION.
- ⑪ CONNECTOR IS LASER MARKED WITH MANUFACTURING INFORMATION. REFER TO DRAWING C-527-4133-000 FOR MARKING REQUIREMENTS AND DETAILS.

CUSTOMER: DISTRIBUTOR / XHD 4PAIR X 8. LC 85OHMS

TOLERANCES	DESIGN	DATE	DESIGNER	Amphenol TCS A Division of Amphenol Corporation 200 Innovative Way, Nashua, NH 03062 803.879.3000	TITLE
0.0	±0.25	10/12/2022	J.LIU		XCede HD DAUGHTERCARD ASSEMBLY
0.00	±0.13	10/12/2022	J.LIU		4 PAIR CONNECTOR, LEADFREE
0.000	±	10/12/2022	J.LIU		
ANGLES	± 3°	11/28/2022	J.LIU		

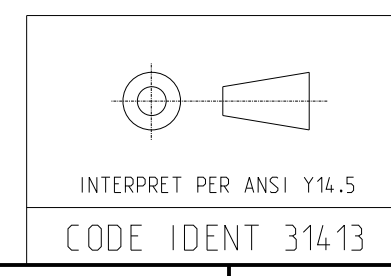

CUSTOMER USE DRAWING

PART NO.	JX410-51597	REV	A
DRAWING NO.	C-JX410-51597		
SIZE	D	SCALE	1/1
		SHEET	1 OF 2

REV	ECN	DESCRIPTION	BY	DATE	APPROVED
		SEE SHEET 1			

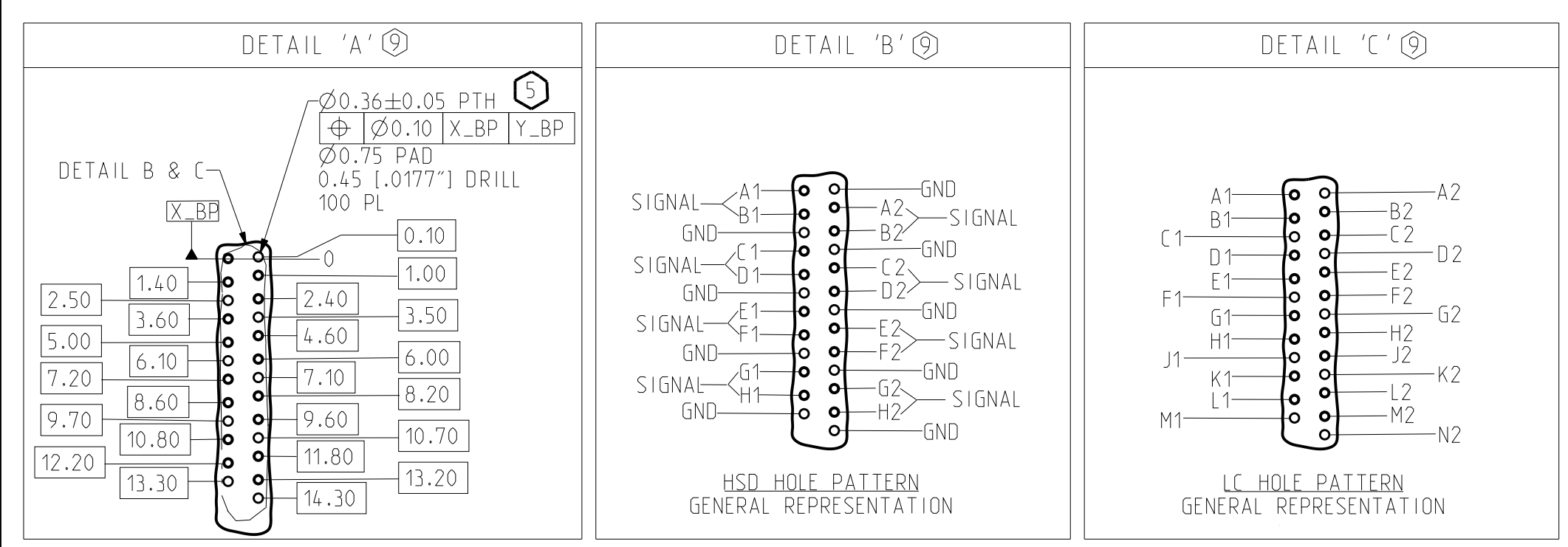

FOR REFERENCE ONLY; FOR SPECIFIC DETAILS, SEE C-USE DRAWINGS FOR BACKPLANE MODULES IN TABLE 2
 BACKPLANE COMPONENTS MUST BE PURCHASED SEPARATELY AND MAY DIFFER FROM EXAMPLE SHOWN

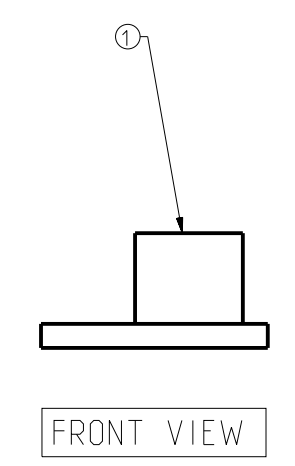
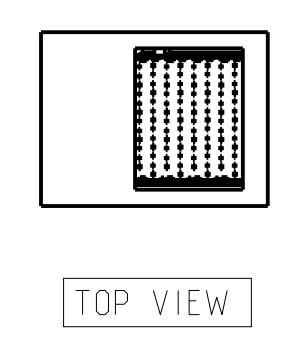
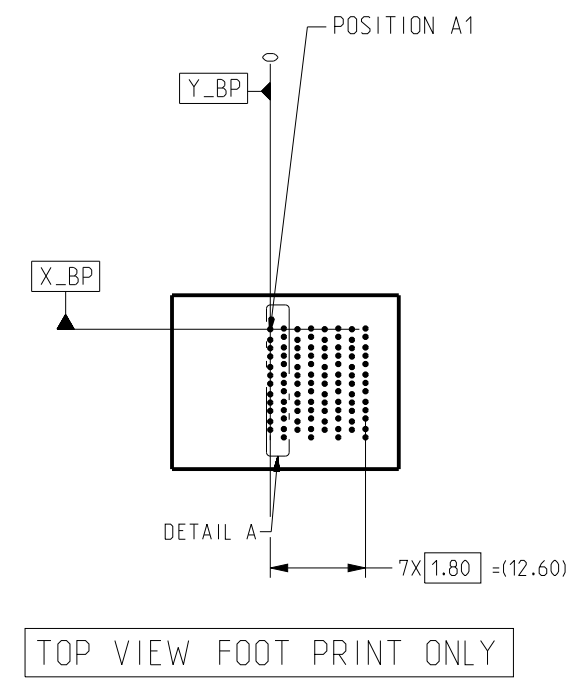

ITEM	PART NUMBER	DESCRIPTION	QTY
1	923-400E-40H	XCede HD 4PAIR 8POS. OPEN, 3MM W IPE, .0177" DRILL, NANO NI, STD GOLD	1

CUSTOMER: DISTRIBUTOR / XHD 4PAIR X 8. LC 850HMS

TOLERANCES	DESIGN 10/12/2022 J.LIU	Amphenol TCS A Division of Amphenol Corporation 200 Innovative Way, Nashua, NH 03062 803.879.3000	TITLE	XCede HD BACKPLANE ASSEMBLY 4 PAIR CONNECTOR, LEADFREE	REV		
0.0 ±0.25	DRAWN 10/12/2022 AUTO GENERATED		PART NO.		JX410-51597	A	
0.00 ±0.13	CHK 10/12/2022 J.LIU		DRAWING NO.		C-JX410-51597		
0.000 ± -	APVD 11/28/2022 J.LIU		CREO FILES JX410-51597_BP_ASM JX410-51597_BP.DRW				
ANGLES ± 3°			SIZE		D	SCALE	1/1

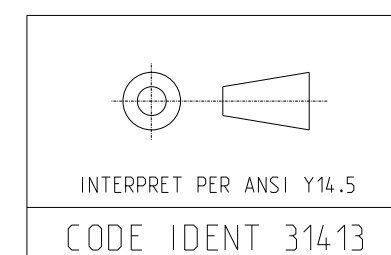

CUSTOMER USE
 DRAWING