

REV	ECN	DESCRIPTION	BY	DATE	APPROVED
A	JLIU-22111611	RELEASE TO PRODUCTION	J.LIU	11/23/2022	J.LIU

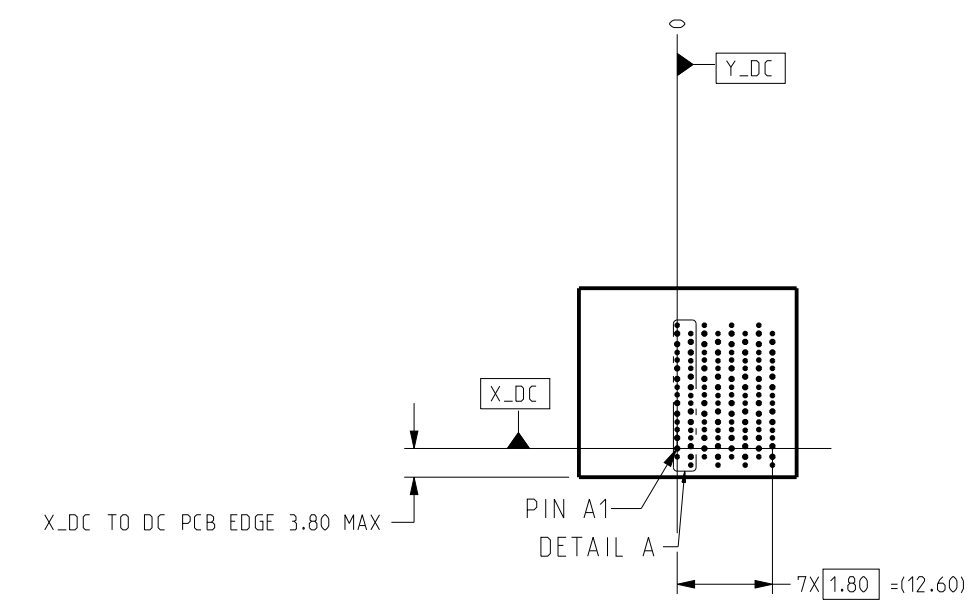

FRONT VIEW - DC HOLE PATTERN ONLY . CONNECTOR SIDE REFERENCED FROM LEFT MOST SIGNAL COLUMN . ALL DIMENSIONS BASIC

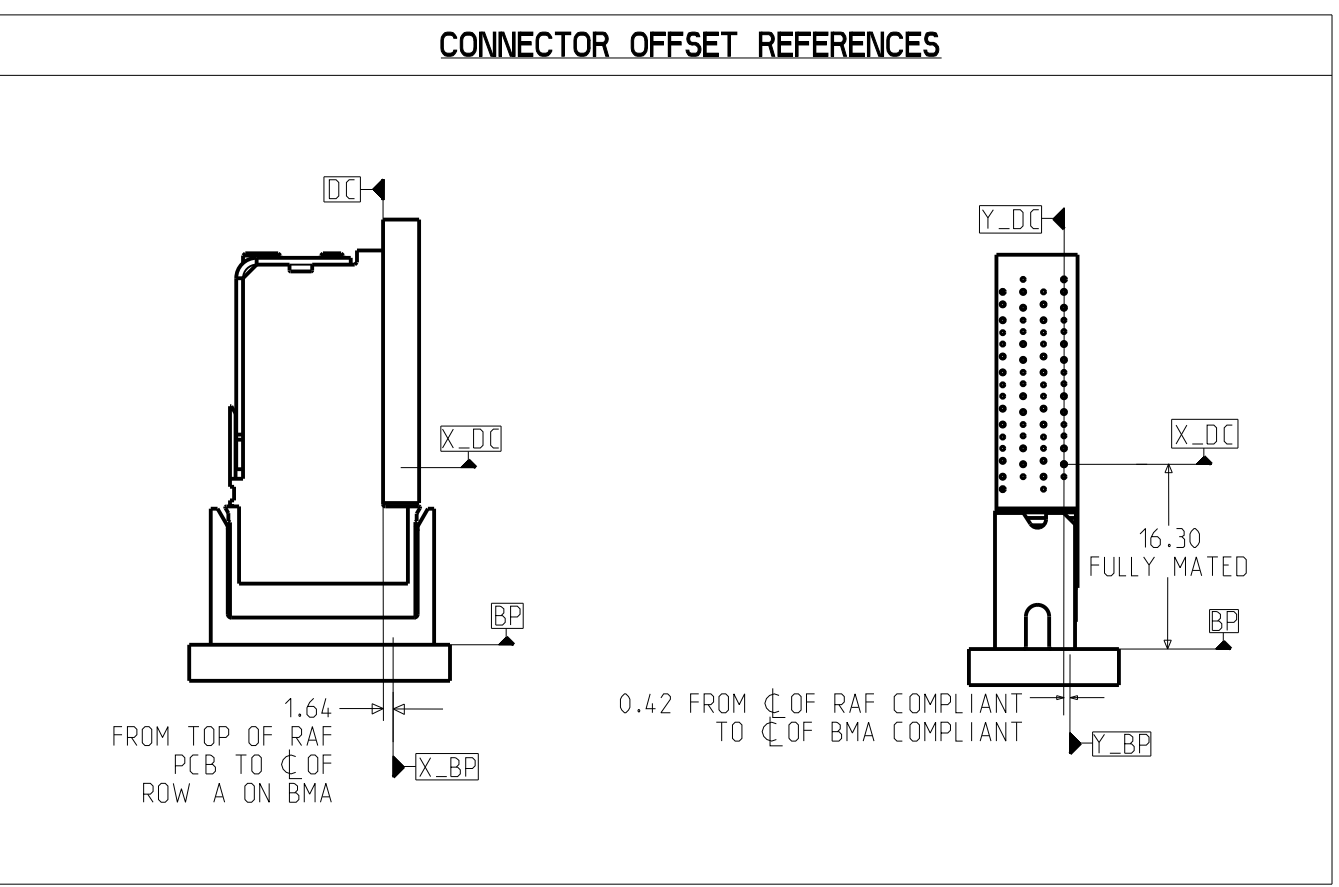
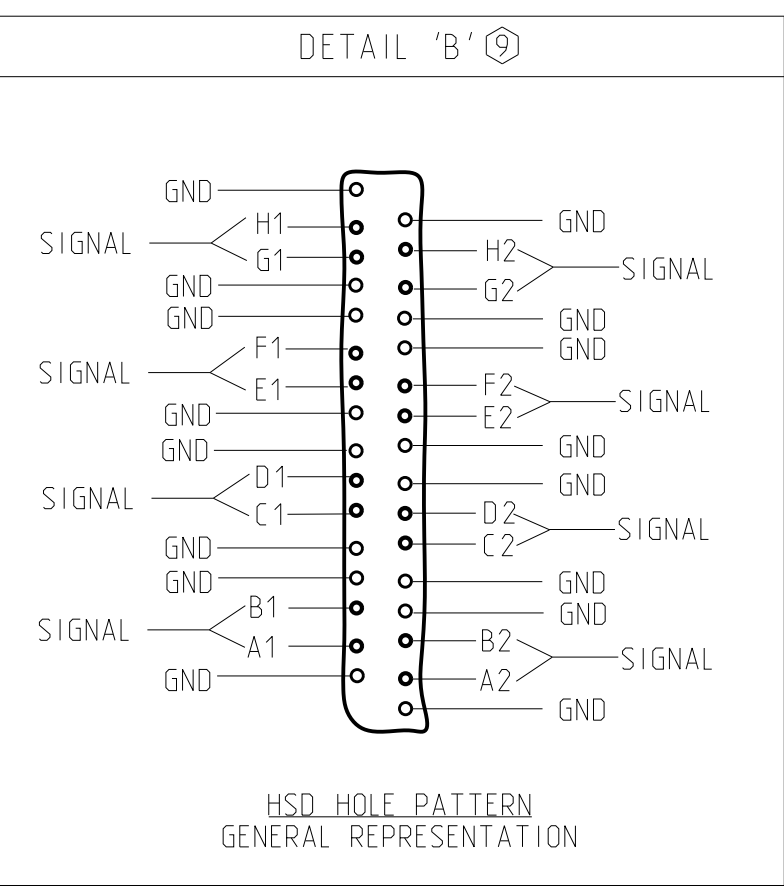
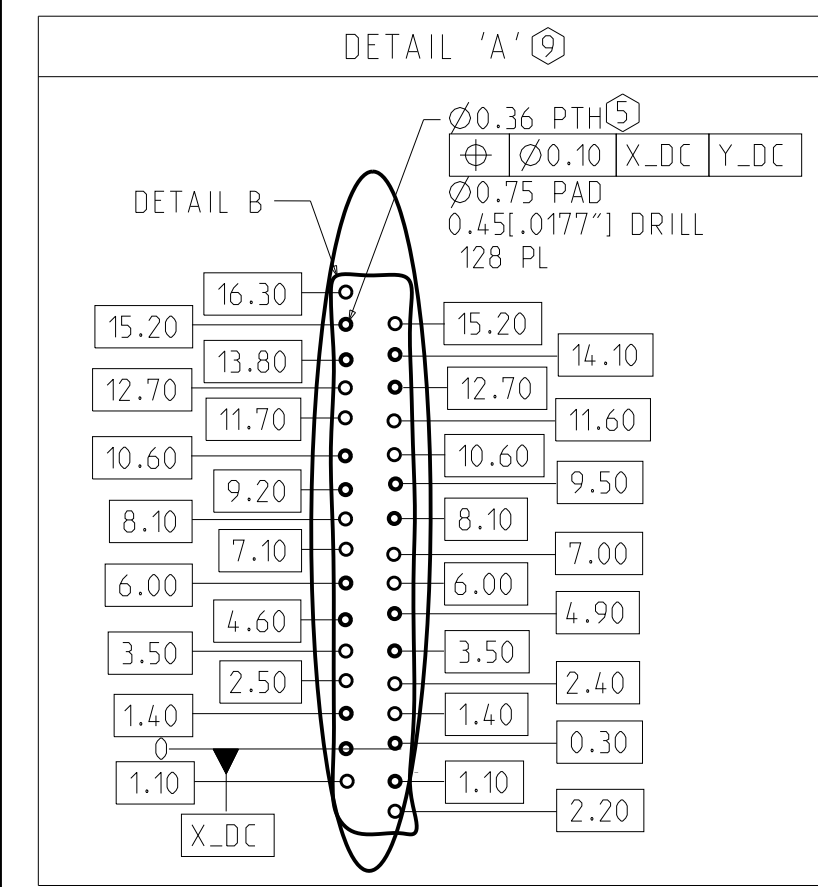
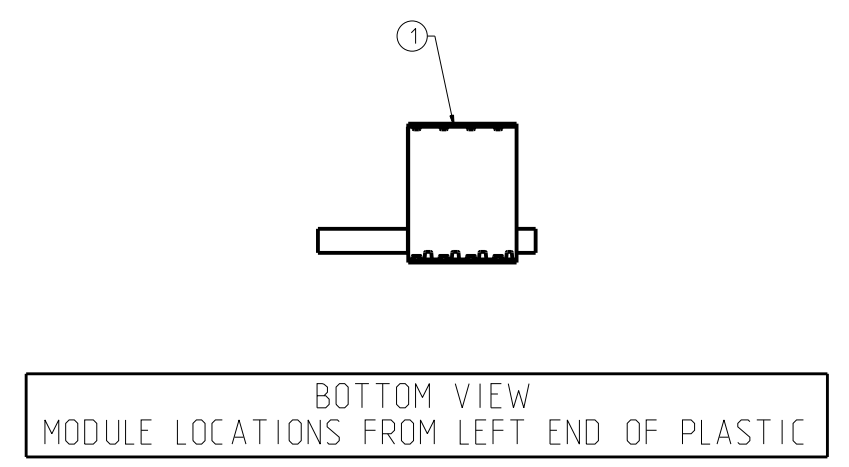
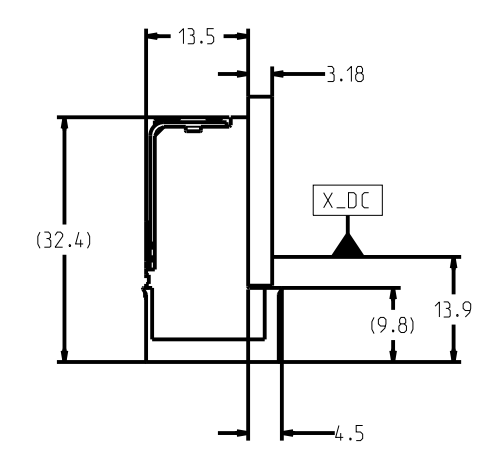
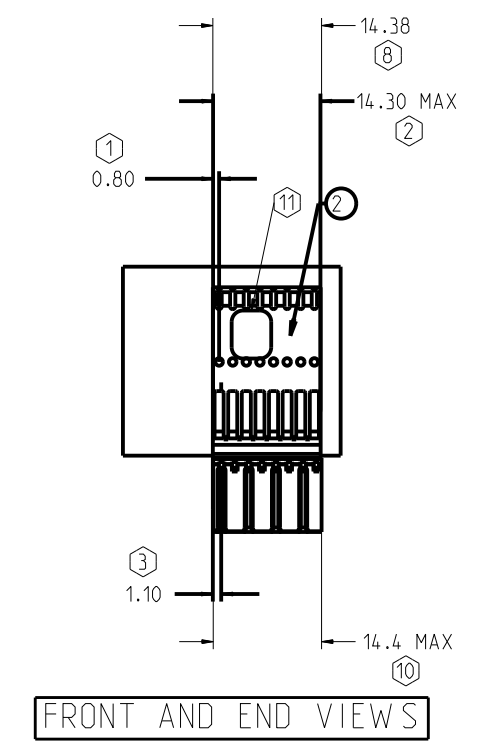

- NOTES:
- DISTANCE FROM FIRST STIFFENER PILOT HOLE TO LEFT END OF STIFFENER.
 - TOTAL LENGTH OF STIFFENER.
 - DISTANCE FROM CENTERLINE OF 1ST COLUMN OF SIGNAL PLATED THRU HOLES TO LEFT EDGE OF CONNECTOR.
 - MOUNTING SCREWS AND JOINER MODULES (IF PRESENT) TO BE BAGGED WITH EACH CONNECTOR ASSEMBLY.
 - STATED PAD SIZE MAY REQUIRE FILLETING. SEE TB-2237 FOR ROUTING, HOLE WALL PLATING THICKNESS AND FINISHED HOLE SIZE.
 - NA.
 - REFER TO TB-2307 FOR XCede HD PLUS PRODUCT SPECIFICATIONS.
 - OVERALL CONNECTOR LENGTH.
 - DETAIL VIEWS ARE NOT TO SCALE. DO NOT SCALE DRAWING.
 - FRONT HOUSING WIDTH. CONNECTORS CAN BE USED IN STACKABLE APPLICATION.
 - CONNECTOR IS LASER MARKED WITH MANUFACTURING INFORMATION. REFER TO DRAWING C-527-4133-000 FOR MARKING REQUIREMENTS AND DETAILS.

TABLE 1: PARTS LIST

ITEM	PART NUMBER	DESCRIPTION	QTY
1	915-430B-BOH	XCede HD PLUS 4PAIR HSD MOD w/ XG, 8POS, 850HMS, .0177" DRILL, NANO NI, STD GOLD	1
2	617-1421-014	XCede HD PLUS 4PAIR STIFFENER	1

NOTE: SEE FRONT VIEW FOR STIFFENER LENGTH.

CUSTOMER: DISTRIBUTOR / XHD PLUS WITH EXTRA GROUND 4PAIR X 8. HSD 850HMS

TOLERANCES	DESIGN 10/13/2022 J.LIU	Amphenol TCS A Division of Amphenol Corporation 200 Innovative Way, Nashua, NH 03062 803.879.3000
0.0 ±0.25	DRAWN 10/13/2022 AUTO GENERATED	
0.00 ±0.13	CHK 10/13/2022 J.LIU	
0.000 ± -	APVD 11/23/2022 J.LIU	
ANGLES ± 3°	UNLESS OTHERWISE SPECIFIED DIMENSIONS ARE IN MM AND DECIMAL MARKER IS A PERIOD.	TITLE XCede HD PLUS DAUGHTERCARD ASSEMBLY 4 PAIR CONNECTOR, LEADFREE PART NO. JX419-50142 DRAWING NO. C-JX419-50142 CRED FILES JX419-50142.ASM JX419-50142.DRW
INTERPRET PER ANSI Y14.5 CODE IDENT 31413		CUSTOMER USE DRAWING SIZE D SCALE 1/1 SHEET 1 OF 2

REV	ECN	DESCRIPTION	BY	DATE	APPROVED
		SEE SHEET 1			

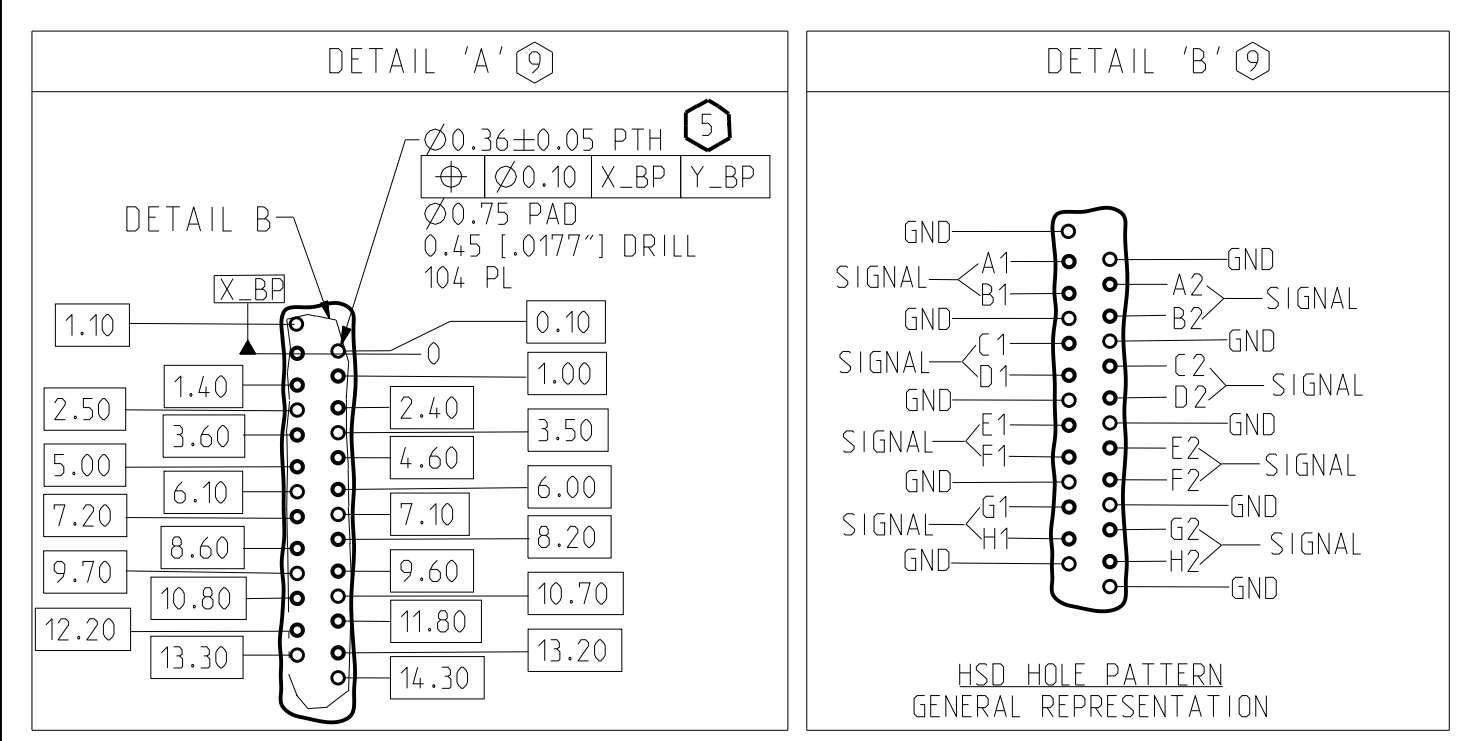

FOR REFERENCE ONLY; FOR SPECIFIC DETAILS, SEE C-USE DRAWINGS FOR BACKPLANE MODULES IN TABLE 2. BACKPLANE COMPONENTS MUST BE PURCHASED SEPARATELY AND MAY DIFFER FROM EXAMPLE SHOWN

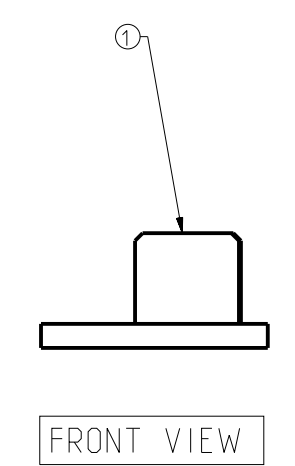
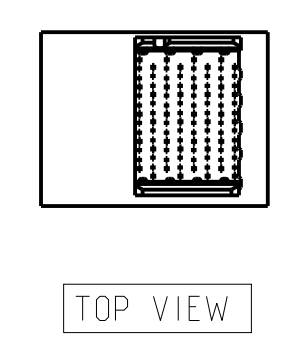
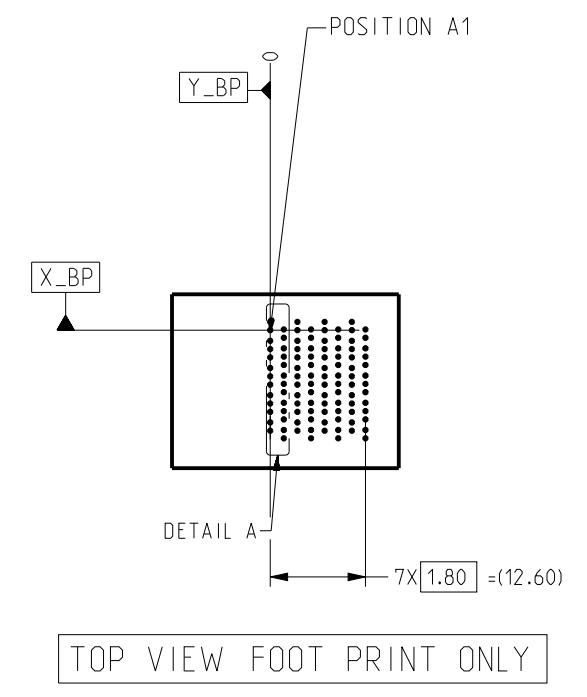

ITEM	PART NUMBER	DESCRIPTION	QTY
1	926-401E-40H	XCede HD PLUS 4PAIR 8POS. OPEN. 3MM WIPE, .0177" DRILL, NANO NI, STD GOLD	1

CUSTOMER: DISTRIBUTOR / XHD PLUS WITH EXTRA GROUND 4PAIR X 8. HSD 850HMS

TOLERANCES	DESIGN 10/13/2022 J.LIU	Amphenol TCS A Division of Amphenol Corporation 200 Innovative Way, Nashua, NH 03062 803.879.3000 TITLE: XCede HD PLUS BACKPLANE ASSEMBLY 4 PAIR CONNECTOR, LEADFREE PART NO. JX419-50142 DRAWING NO. C-JX419-50142 CRED FILES JX419-50142_BP_ASM JX419-50142_BP.DRW	REV A
0.0	±0.25 DRAWN 10/13/2022 AUTO GENERATED		
0.00	±0.13 CHK 10/13/2022 J.LIU		
0.000	± - APVD 11/23/2022 J.LIU		
ANGLES	± 3°		

UNLESS OTHERWISE SPECIFIED DIMENSIONS ARE IN MM AND DECIMAL MARKER IS A PERIOD.

INTERPRET PER ANSI Y14.5
CODE IDENT 31413

CUSTOMER USE DRAWING

SIZE D SCALE 1/1 SHEET 2 OF 2