

REVISIONS			
REV	DESCRIPTION, ECN, EAR NO.	DATE	APP'D
A	INITIAL RELEASE	AUG16/22	K.T

NOTES:

- ELECTRICAL:**
- 60 VDC WITH MAXIMUM POWER 100 W
 - CURRENT RATING: 1.25 AMPS PER CONTACT.
 - INSULATING RESISTANCE : 500 MEGAOHMS MINIMUM.
 - DIELECTRIC STRENGTH : 1000 VAC 60Hz, 1MIN.
 - CATEGORY 6 CHARACTERISTIC

FREQUENCY MHZ	NEAR-END CROSSTALK dB, MIN.	RETURN LOSS dB, MIN.	INSERTION LOSS dB, MAX.
1.0	75.0	30.0	0.1
4.0	75.0	30.0	0.1
8.0	75.0	30.0	0.1
10.0	74.0	30.0	0.1
16.0	69.9	30.0	0.1
20.0	68.0	30.0	0.1
25.0	66.0	30.0	0.1
31.25	64.1	30.0	0.11
62.5	58.1	28.1	0.16
100.0	54.0	24.0	0.20
200.0	48.0	18.0	0.28
250.0	46.0	16.0	0.32

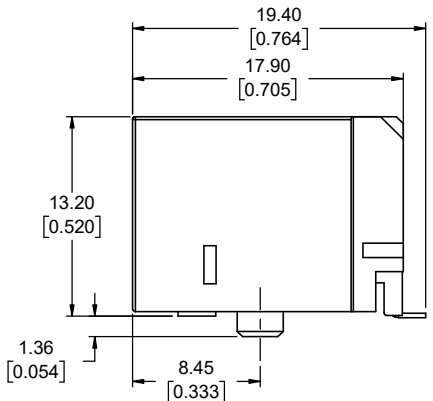
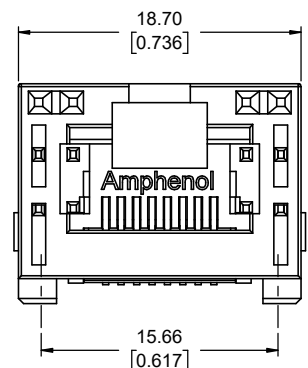
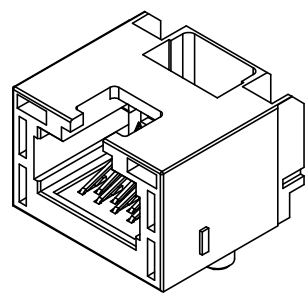
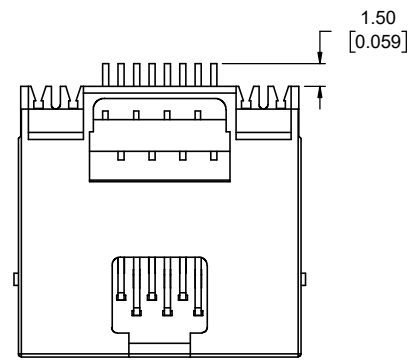

MECHANICAL:

- HOUSING: HIGH TEMP THERMOPLASTIC. UL 94V-0.
- CONTACT: PHOSPHOR BRONZE.
SELECTIVE GOLD PLATING FOR MATING SURFACE,
50u" MIN. NICKEL UNDERPLATE
100u" MATTE TIN PLATING ON CONTACT SOLDER TAIL.
- COPLANARITY:
THE MAXIMUM GAP BETWEEN ALL TERMINAL TAILS IS 0.10 [0.004]

ENVIRONMENTAL:

- OPERATING TEMPERATURE: -55 °C TO +85 °C
- MATES WITH MODULAR PLUG CONFORMING TO TIA 1096 STANDARD.
- RECOMMENDED SOLDER PROCESS:
REFLOW SOLDER, PEAR TEMPERATURE 260°C FOR 10 SECONDS MAX.

RJ CONNECTOR CONFORMS TIA 1096

AMPHENOL PART NUMBER DESCRIPTION: RJE3B-188-0X02

GOLD PLATING OPTION
 1=6u" GOLD PLATING
 2=15u" MIN GOLD PLATING
 3=30u" MIN GOLD PLATING
 4=50u" MIN GOLD PLATING

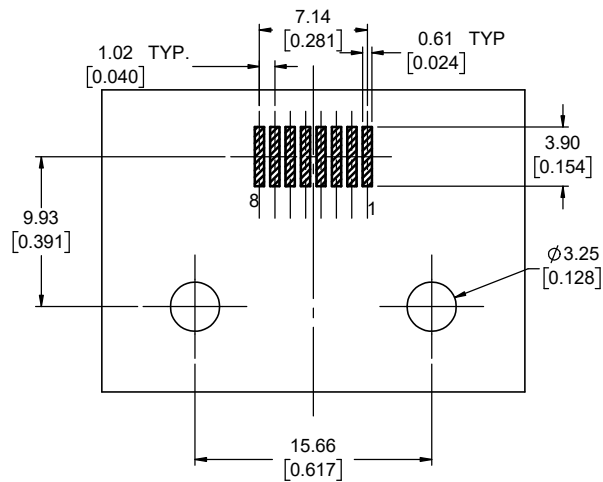

RECOMMENDED PCB LAYOUT
VIEW FROM COMPONENT SIDE
TOLERANCE: +/-0.05[0.002]

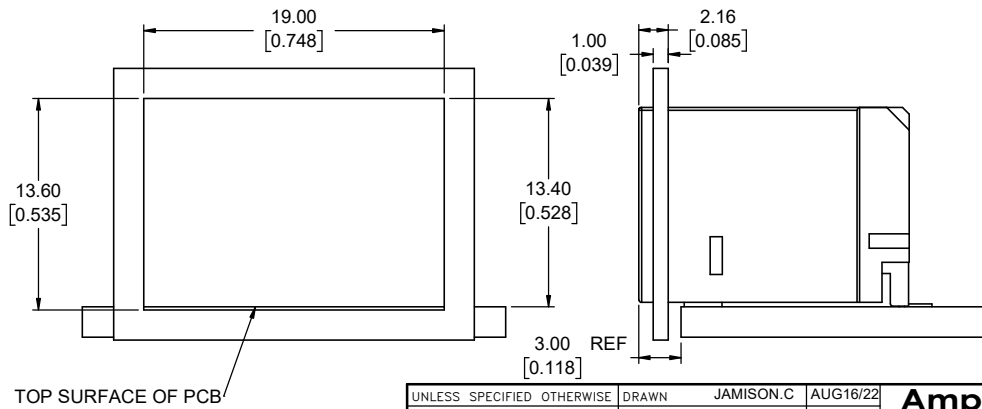

TOP SURFACE OF PCB

UNLESS SPECIFIED OTHERWISE	DRAWN	JAMISON.C	AUG16/22
PRIMARY UNITS MILLIMETERS	CHECKED	L.CHAN	AUG16/22
SECONDARY INCHES	M.E. APP'D		
REFERENCE IN PARENTHESES	Q.A. APP'D		
GENERAL TOLERANCES	DWG APPR.	A.GREEN	AUG16/22
1 DECIMAL PLACE	REF. REL. NO.		
2 DECIMAL PLACES ±0.25	REF.		
3 DECIMAL PLACES ±0.13	THIRD ANGLE PROJECTION		
ANGULAR DEGREES ±1°	DO NOT SCALE DRAWING		

Amphenol Canada Corp.
Commercial Products

MODULAR JACK, SINGLE PORT, 8P8C,
UNSHIELDED, TAB UP, W/O LED, WITH
POSITION PEG, CAT 6, RoHS COMPLIANT

DWG. NO. **P-RJE3B-188-0X02** REV **A**

CODE ID NO. 03554 | DWG SIZE: N/A | SCALE: FIT | SHEET 1 OF 2

REVISIONS			
REV	DESCRIPTION, ECN, EAR NO.	DATE	APP'D
A	INITIAL RELEASE	AUG16/22	K.T

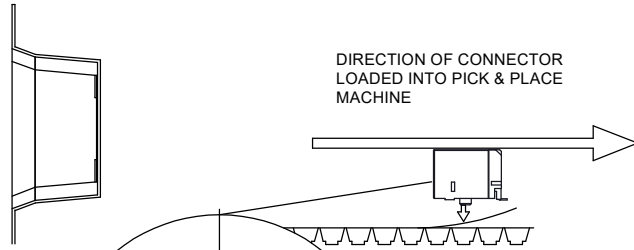
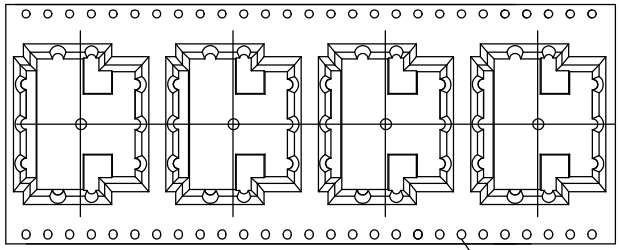

DIRECTION OF CONNECTOR
LOADED INTO PICK & PLACE
MACHINE

Ø1.5

5 REELS

ALUMINIUM FOIL BAGS
ONE BAG PER REEL

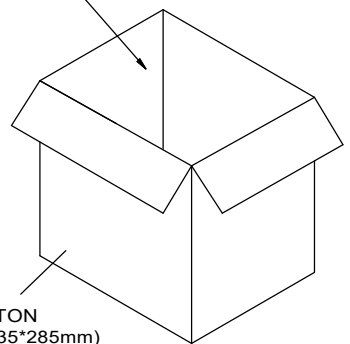
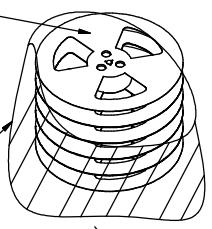

CARTON
(335*335*285mm)

SEAL CARTON

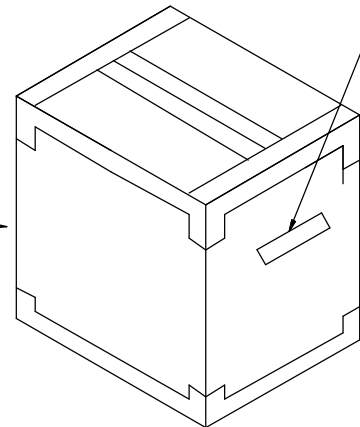

AMPHENOL P/N: RJE3B1880X02
 LOT# DATE CODE CTY OF ORIGIN: CN



NOTES:

1. FINISHED CONNECTORS (AFTER FINAL INSPECTION) TO BE PACKED INTO CONDUCTIVE HIPS TAPE AND REEL. ONE REEL SHOULD HOLD 125 PCS CONNECTORS.
2. 13 EMPTY POCKETS SEALED OF TAPE LEADER AND 6 EMPTY POCKETS SEALED OF TAPE TRAILER.
3. A FULLY LOADED CARTON SHOULD CONTAIN 5 REELS (625 PCS) OF CONNECTORS.

UNLESS SPECIFIED OTHERWISE	DRAWN	JAMISON.C	AUG16/22
PRIMARY UNITS MILLIMETERS	CHECKED	L.CHAN	AUG16/22
SECONDARY INCHES	M.E.	APP'D	
REFERENCE IN PARENTHESES	Q.A.	APP'D	
GENERAL TOLERANCES	DWG APPR.	A.GREEN	AUG16/22
1 DECIMAL PLACE	ENG. REL. NO.		
2 DECIMAL PLACES ±0.25	REF.		
3 DECIMAL PLACES ±0.13	THIRD ANGLE PROJECTION		
ANGULAR DEGREES ±1°	DO NOT SCALE DRAWING		

Amphenol Canada Corp.
Commercial Products

MODULAR JACK, SINGLE PORT, 8P8C, UNSHIELDED, TAB UP, W/O LED, WITH POSITION PEG, CAT 6, RoHS COMPLIANT

DWG. NO. **P-RJE3B-188-0X02** REV **A**

CODE ID NO. 03554 DWG SIZE: N/A SCALE: FIT SHEET 2 OF 2