

REVISIONS			
REV	DESCRIPTION, ECN, EAR NO.	DATE	APP'D
A	INITIAL RELEASE	AUG16/22	K.T

NOTES:

- ELECTRICAL:**
- 60 VDC WITH MAXIMUM POWER 100 W
 - CURRENT RATING: 1.25 AMPS PER CONTACT.
 - INSULATING RESISTANCE : 500 MEGAOHMS MINIMUM.
 - DIELECTRIC STRENGTH : 1000 VAC 60Hz, 1MIN.
 - CATEGORY 6 CHARACTERISTIC

FREQUENCY MHZ	NEAR-END CROSSTALK dB, MIN.	RETURN LOSS dB, MIN.	INSERTION LOSS dB, MAX.
1.0	75.0	30.0	0.1
4.0	75.0	30.0	0.1
8.0	75.0	30.0	0.1
10.0	74.0	30.0	0.1
16.0	69.9	30.0	0.1
20.0	68.0	30.0	0.1
25.0	66.0	30.0	0.1
31.25	64.1	30.0	0.11
62.5	58.1	28.1	0.16
100.0	54.0	24.0	0.20
200.0	48.0	18.0	0.28
250.0	46.0	16.0	0.32

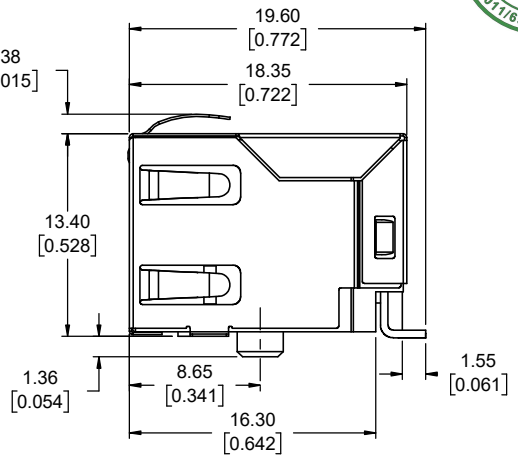
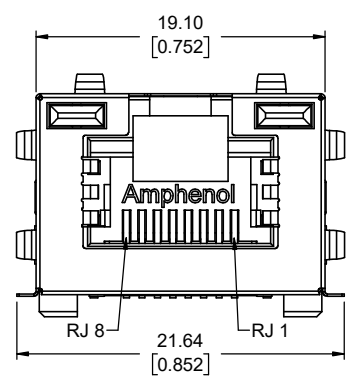
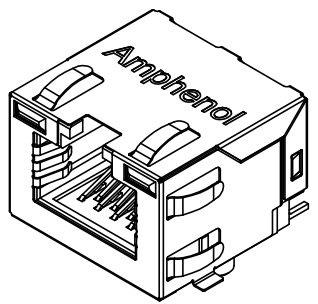
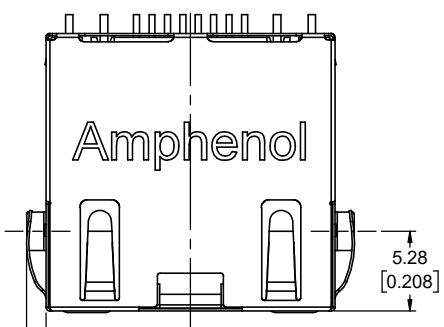

MECHANICAL:

- SHIELD: STAINLESS STEEL WITH 100u" MATTE TIN OVER 20u" MIN. NICKEL UNDERPLATE
- HOUSING: HIGH TEMP THERMOPLASTIC. UL 94V-0.
- CONTACT: PHOSPHOR BRONZE. SELECTIVE GOLD PLATING FOR MATING SURFACE, 50u" MIN. NICKEL UNDERPLATE 100u" MATTE TIN PLATING ON CONTACT SOLDER TAIL.
- COPLANARITY: THE MAXIMUM GAP BETWEEN ALL TERMINAL TAILS IS 0.10 [0.004]

ENVIRONMENTAL:

- OPERATION: -55 °C TO +85°C
- MATES WITH MODULAR PLUG CONFORMING TO TIA 1096 STANDARD.
- RECOMMENDED SOLDER PROCESS: REFLOW SOLDER, PEAK TEMPERATURE 260°C FOR 10 SECONDS MAX.

RJ CONNECTOR CONFORMS TIA-1096 STANDARD

AMPHENOL PART NUMBER DESCRIPTION: RJE3B-188-1XX2

GOLD PLATING OPTION
 1=6u" GOLD PLATING
 2=15u" MIN GOLD PLATING
 3=30u" MIN GOLD PLATING
 4=50u" MIN GOLD PLATING

LED COLOR CODE
SEE PAGE 2

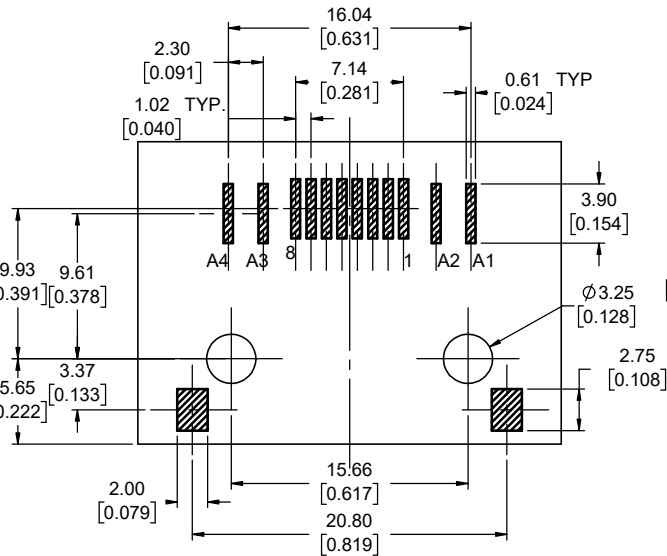

RECOMMENDED PCB LAYOUT
VIEW FROM COMPONENT SIDE
TOLERANCE: +/-0.05[0.002]

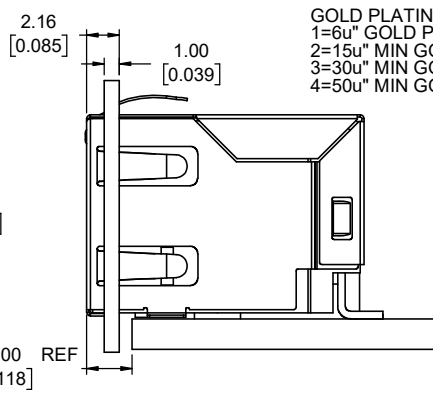
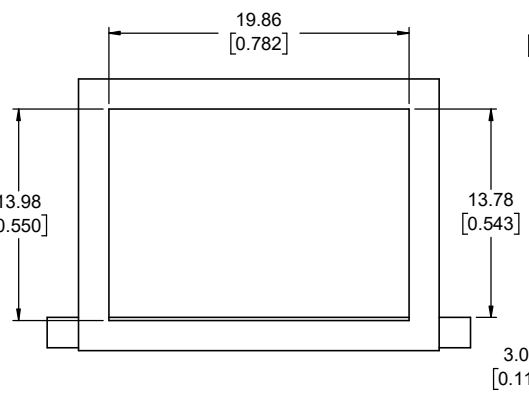

UNLESS SPECIFIED OTHERWISE	DRAWN	JAMISON.C	DEC10/20
PRIMARY UNITS MILLIMETERS	CHECKED	L.CHAN	DEC10/20
SECONDARY INCHES	M.E. APP'D		
REFERENCE IN PARENTHESES	Q.A. APP'D		
GENERAL TOLERANCES	DWG APPR.		
1 DECIMAL PLACE	ENG. REL. NO.		
2 DECIMAL PLACES ±0.25	REF.		
3 DECIMAL PLACES ±0.13			
ANGULAR DEGREES ±1°			
	THIRD ANGLE PROJECTION	DO NOT SCALE DRAWING	

Amphenol Canada Corp.
Commercial Products

MODULAR JACK, SINGLE PORT, 8P8C,
 SHIELDED, TAB UP, WITH LED,
 CAT 6---RoHS COMPLIANT

DWG. NO. **P-RJE3B-188-1XX2** REV **A**

CODE ID NO. 03554 | DWG SIZE: N/A | SCALE: FIT | SHEET 1 OF 3

REVISIONS			
REV	DESCRIPTION, ECN, EAR NO.	DATE	APP'D
A	INITIAL RELEASE	AUG16/22	K.T

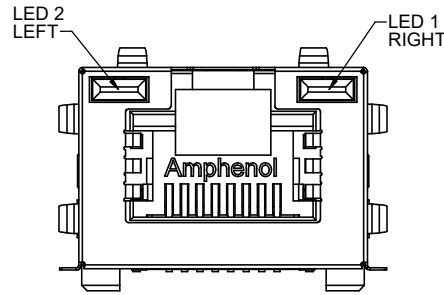

LED SCHEMATIC

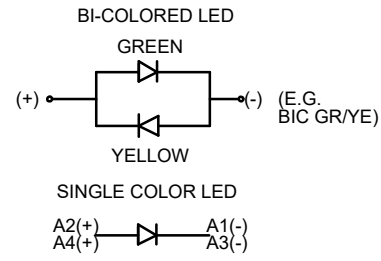

CODE	LED 2 (LEFT)	LED 1 (RIGHT)	CODE	LED 2 (LEFT)	LED 1 (RIGHT)	CODE	LED 2 (LEFT)	LED 1 (RIGHT)
0	BLOCKED	BLOCKED	9	GREEN	BLOCKED	J	BiC RD/GR	YELLOW
1	YELLOW	GREEN	A	BiC GR/YE	BiC GR/YE	K	YELLOW	BiC GR/OR
2	BLOCKED	GREEN	B	BiC RD/GR	BiC RD/GR	L	BiC GR/YE	RED
3	YELLOW	BLOCKED	C	BiC RD/GR	BiC GR/YE	M	RED	YELLOW
4	GREEN	YELLOW	D	GREEN	BiC GR/YE	N	BiC GR/RD	BiC GR/YE
5	GREEN	GREEN	E	YELLOW	BiC GR/YE	P	GREEN	BiC GR/RD
6	YELLOW	YELLOW	F	BiC GR/YE	YELLOW	R	BiC GR/OR	GREEN
7	RED	GREEN	G	BiC GR/OR	BiC GR/OR	T	RED	RED
8	GREEN	RED	H	BiC GR/YE	GREEN	V	BiC RD/GR	GREEN
			W	ADDITIONAL OPTIONS				

LED SPECIFICATIONS:
 FORWARD VOLTAGE: 1.6 VOLTS TYP.
 REVERSE VOLTAGE: 5.0 VOLTS MAX.
 LUMINOUS INTENSITY: 0.4 mCd MIN.
 (AT IF=2mA)
 PLATING ON TAILS: TIN OR TIN/COPPER ALLOY OVER SILVER

LEGEND
 BiC=BI-COLOR LED
 LOWC=LOW CURRENT LED
 YE=YELLOW
 GR=GREEN
 RE=RED
 OR=ORANGE

PRIMARY COLOR FOR BI-COLOR LEDS IN STANDARD ANODE/CATHODE CONFIGURATION IS:
 RED-GREEN= RED
 RED-YELLOW= RED
 GREEN-YELLOW= GREEN
 GREEN-ORANGE= GREEN

NOTE:
 THE TWO DIGITS PRECEDING THE ADDITIONAL LED CODE MUST BE USED IN THE PART NUMBER, WHEN ORDERING ANY OF THE ADDITIONAL LED OPTIONS.

EXAMPLE OF ADDITIONAL LED OPTIONS:

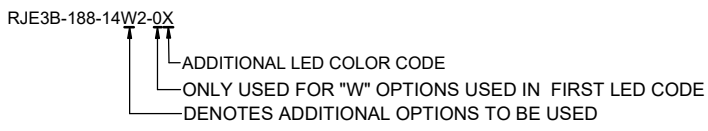

CODE	LED 2 (LEFT)	LED 1 (RIGHT)	CODE	LED 2 (LEFT)	LED 1 (RIGHT)	CODE	LED 2 (LEFT)	LED 1 (RIGHT)
0	DO NOT USE		5	BLOCKED	YELLOW	A	LOWC YE	LOWC YE
1	RED	BLOCKED	6	RED	BiC RD/GR	B	LOWC YE	LOWC GR
2	BiC GR/OR	YELLOW	7	BLOCKED	BiC RD/GR	C	LOWC GR	LOWC YE
3	YELLOW	RED	8	BiC RD/GR	BLOCKED	D	LOWC GR	LOWC GR
4	BLOCKED	RED	9	BiC GR/YE	BLOCKED	M	LOWC RD	LOWC YE
			E	GREEN	ORANGE			
			F	ORANGE	GREEN			
			G	BiC OR/GR	BiC OR/GR			
			H	BiC GR/OR	ORANGE			



THIS DOCUMENT CONTAINS PROPRIETARY INFORMATION AND SUCH INFORMATION MAY NOT BE DISCLOSED TO OTHERS FOR ANY PURPOSE OR USED FOR MANUFACTURING PURPOSES WITHOUT WRITTEN PERMISSION FROM AMPHENOL CANADA CORP.

UNLESS SPECIFIED OTHERWISE	DRAWN	JAMISON.C	DEC10/20
PRIMARY UNITS MILLIMETERS	CHECKED	L.CHAN	DEC10/20
SECONDARY INCHES	M.E. APP'D		
REFERENCE IN PARENTHESES	Q.A. APP'D		
GENERAL TOLERANCES	DWG APPR.		
1 DECIMAL PLACE	ENG. REL. NO.		
2 DECIMAL PLACES ±0.25	REF.		
3 DECIMAL PLACES ±0.13			
ANGULAR DEGREES ±1°	THIRD ANGLE PROJECTION		
	DO NOT SCALE DRAWING		

Amphenol Canada Corp.
 Commercial Products

MODULAR JACK, SINGLE PORT, 8P8C, SHIELDED, TAB UP, WITH LED, CAT 6---RoHS COMPLIANT

DWG. NO. **P-RJE3B-188-1XX2** REV **A**

CODE ID NO. 03554 | DWG. SIZE: N/A | SCALE: FIT | SHEET 2 OF 3

REVISIONS			
REV	DESCRIPTION, ECN, EAR NO.	DATE	APP'D
A	INITIAL RELEASE	AUG16/22	K.T

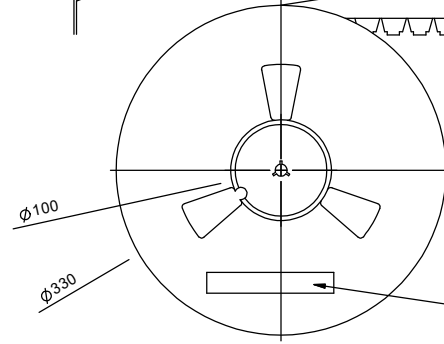
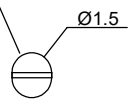
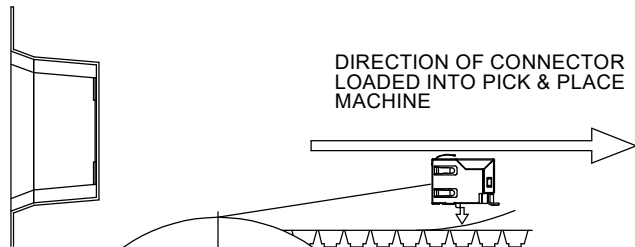
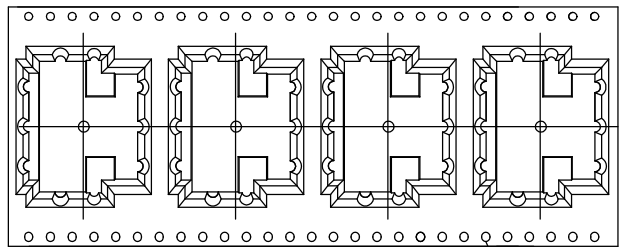

AMPHENOL P/N: RJE3B1881XX2
 LOT# DATE CODE CTY OF ORIGIN: CN

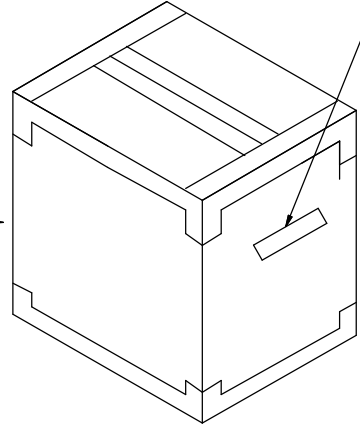
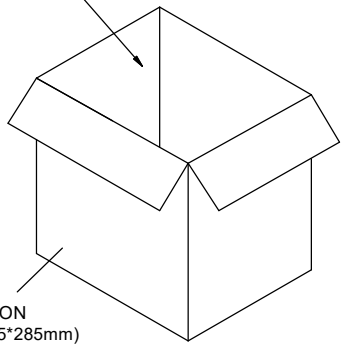
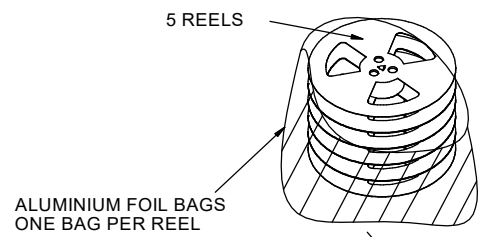

NOTES:

1. FINISHED CONNECTORS (AFTER FINAL INSPECTION) TO BE PACKED INTO CONDUCTIVE HIPS TAPE AND REEL. ONE REEL SHOULD HOLD 125 CONNECTORS.
2. 13 EMPTY POCKETS SEALED OF TAPE LEADER AND 6 EMPTY POCKETS SEALED OF TAPE TRAILER.
3. A FULLY LOADED CARTON SHOULD CONTAIN 5 REELS (625 PCS) OF CONNECTOR.

UNLESS SPECIFIED OTHERWISE	DRAWN	JAMISON.C	DEC10/20
PRIMARY UNITS MILLIMETERS	CHECKED	L.CHAN	DEC10/20
SECONDARY INCHES	M.E.	APP'D	
REFERENCE IN PARENTHESES	Q.A.	APP'D	
GENERAL TOLERANCES	DWG APPR.		
1 DECIMAL PLACE	ENG. REL. NO.		
2 DECIMAL PLACES ±0.25	REF.		
3 DECIMAL PLACES ±0.13	THIRD ANGLE PROJECTION		
ANGULAR DEGREES ±1°	DO NOT SCALE DRAWING		

Amphenol Canada Corp.
 Commercial Products

MODULAR JACK, SINGLE PORT, 8P8C,
 SHIELDED, TAB UP, WITH LED,
 CAT 6---RoHS COMPLIANT

DWG. NO. **P-RJE3B-188-1XX2** REV **A**

CODE ID NO. 03554 | DWG SIZE: N/A | SCALE: FIT | SHEET 3 OF 3