

REVISIONS				
REV.	ECN	DESCRIPTION	DATE	APPROVED
A		PROPOSAL	02-MAR-20	J.SI

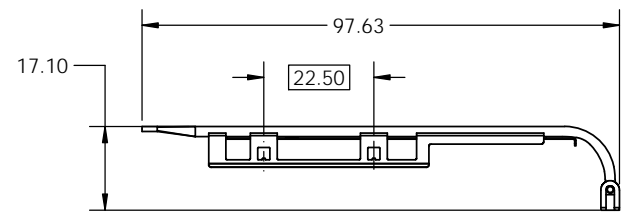

NOTES:

- MATERIAL:
 LIGHT PIPE: CLEAR POLYCARBONATE
 LIGHT PIPE COVER: HIGH TEMP PLASTIC UL94-V0
 LIGHT PIPE BRACKET: CLIP:STAINLESS STEEL
- PACKAGING: TRAY PACKAGING.
- AMPHENOL PART NUMBER: **U62-1263-4012P**

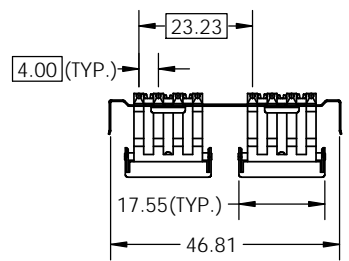
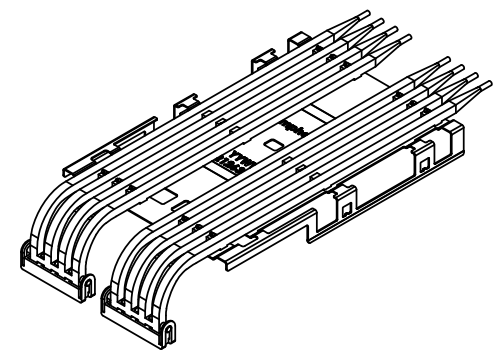
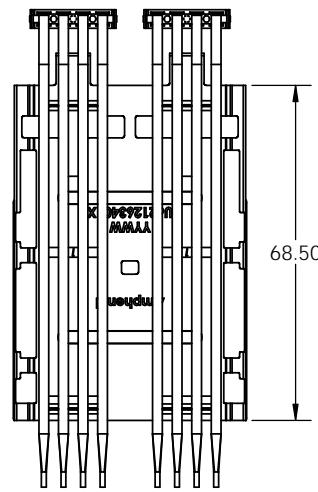

DO NOT SCALE DRAWING

THIS DOCUMENT CONTAINS PROPRIETARY INFORMATION AND SUCH INFORMATION MAY NOT BE DISCLOSED TO OTHERS FOR ANY PURPOSE OR USED FOR MANUFACTURING PURPOSES WITHOUT PERMISSION FROM AMPHENOL CANADA CORP.

UNLESS OTHERWISE SPECIFIED DIMENSIONS ARE IN MILLIMETERS TOLERANCES ARE: DECIMALS ANGLES X.X ± 0.35 ± 0.5° X.XX ± 0.25		APPROVALS	DATE	Amphenol High Speed Interconnects <small>A Division of Amphenol Corp. www.amphenol-highspeed.com</small>	
DRAWN: Galen.L		02-MAR-20		TITLE	
DESIGNED: Chigow.X		02-MAR-20		1X4 OSFP LP AND COVER AND BRACKET ASSY	
MATERIAL AND FINISH: SEE NOTE 1		QA APPD:			
REF:	E APPD:	J.SI	02-MAR-20	SIZE: A3	DWG. NO: P-U62-1263-4012P
CODE IDENT. NO: 03554	DWG APPD:	J.SI	02-MAR-20	SCALE: 1:1	PROJECT: UE62 SHEET: 1 OF 1