

1

2

3

4

REV.	ECR/ECN No.	DESCRIPTION	DRAWN/DATE	CHECKED/DATE	APPROVED/DATE
A	ECN20200112	NEW RELEASE	Staven 2020-12-30	Staven 2020-12-30	Biao 2020-12-30

NOTES:

- 1) MATERIALS: PHOSPHOR BRONZE T=0.15mm.
- 2) FINISH:GOLD FLASH SURFACE PLATING OVER CONTACT AREAS, GOLD FLASH SURFACE PLATING OVER SOLDER AREAS, Ni 40-120u" UNDER PLATING OVER ALL.
- 3) ALLOWING BURRS 0.03mm Max.
- 4) THE SURFACE IS NOT ALLOWED TO HAVE CRUSHING; SCRATCH;DEFORMATION;DIE MARKS;OIL STAINS.
- 5) "○"THE SYMBOL INDICATES THE DIMENSION OF KEY FUNCTION INSPECTION.
- 6) WITH "▼"MUST BE CPK CONTROL.

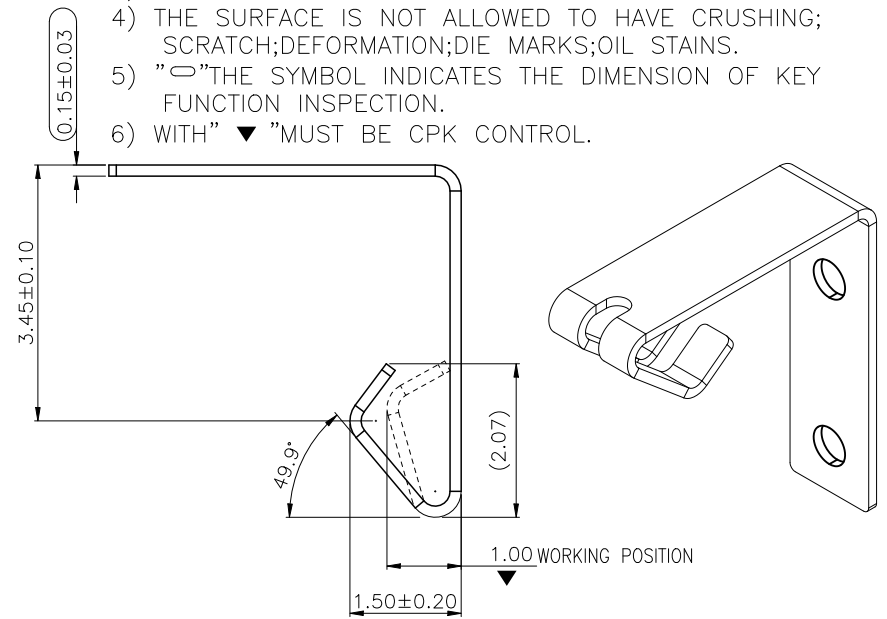
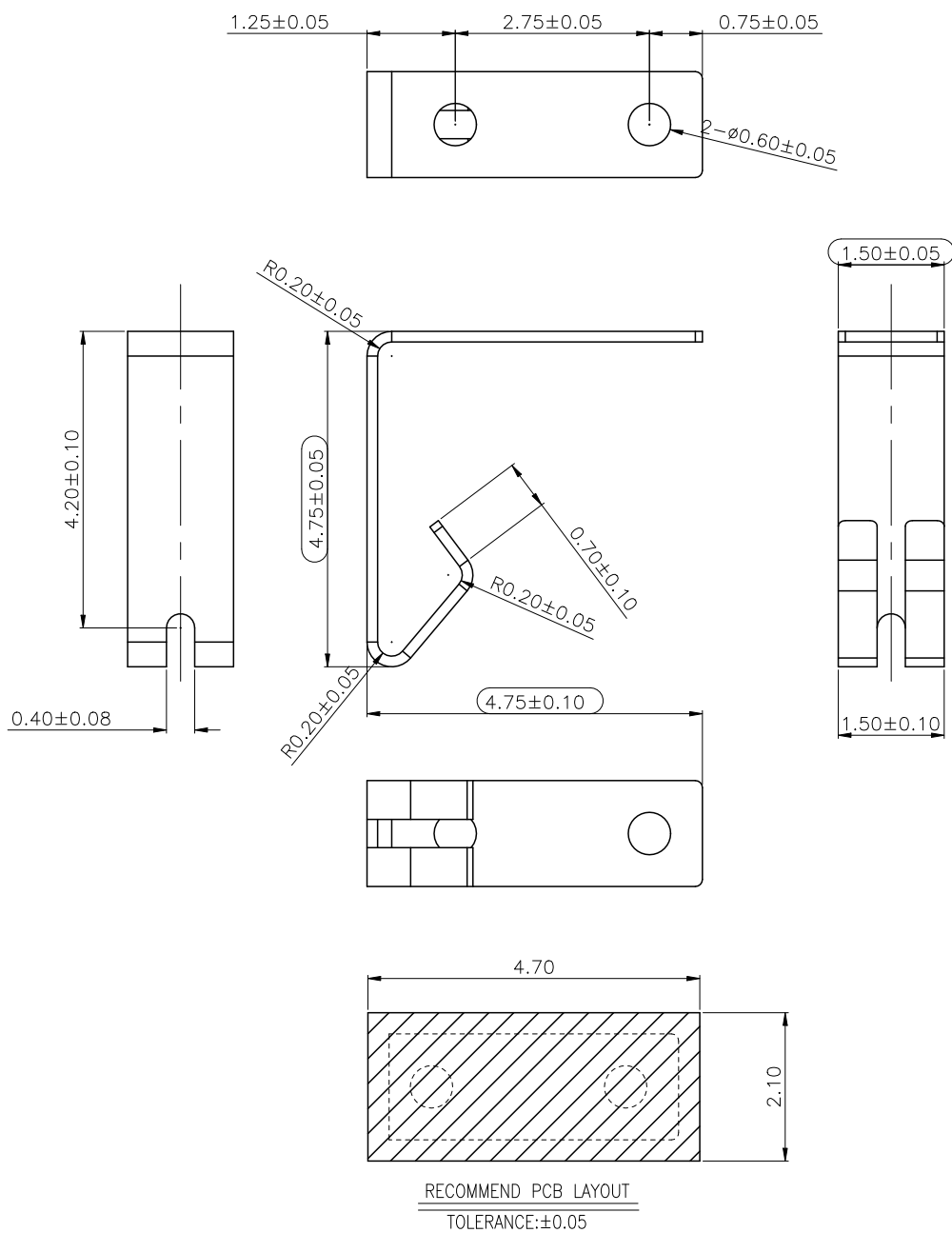

UNLESS OTHERWISE SPECIFIED TOLERANCES		ANGLE OF PROJECTION		 Amphenol Aorora Technology (Huizhou) Co.,Ltd			
X.	±0.30	X. °	± 5'				
X.X	±0.25	X.X °	± 4'	DOC TYPE	Customer Drw		TITLE:
X.XX	±0.20	X.XX °	± 3'	DRAWN	Staven	PCB CONTACT SPRING	
X.XXX	±0.15	X.XXX °	± 2'	DATE	2020-12-30	SIZE	A4
LINEAR DIMS		ANGLES DIMS		DESIGN	Staven	PART NUMBER:	
DWG NO.: A-S0620				DATE	2020-12-30	Z02H-4F7L1-11000	
MATERIAL	SEE NOTES			CHECKED	Biao	REV.	A
FINISHED	SEE NOTES			DATE	2020-12-30	SCALE	1:1
				APPROVED	Biao	UNIT : mm	SHEET 1 OF 1
				DATE	2020-12-30		

Amphenol AORORA

This document is the property of and embodies CONFIDENTIAL and PROPRIETARY information of AOR. No part of the information shown on this document may be used in any way or disclosed to others without the written consent of AOR. © 2019 AOR

1

2

3

4

REV.	ECR/ECN No.	DESCRIPTION	DRAWN/DATE	CHECKED/DATE	APPROVED/DATE
A	ECN20200112	NEW RELEASE	Staven 2020-12-30	Staven 2020-12-30	Biao 2020-12-30

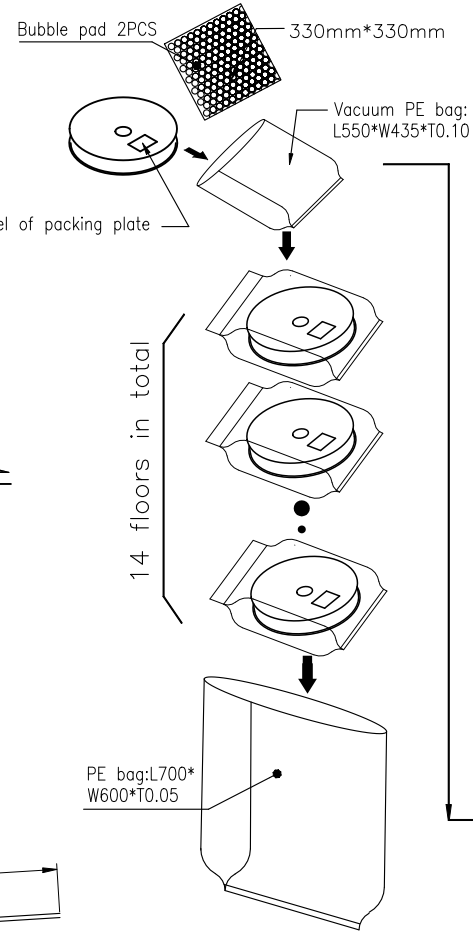
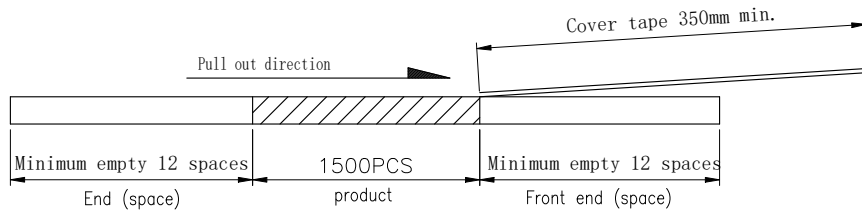
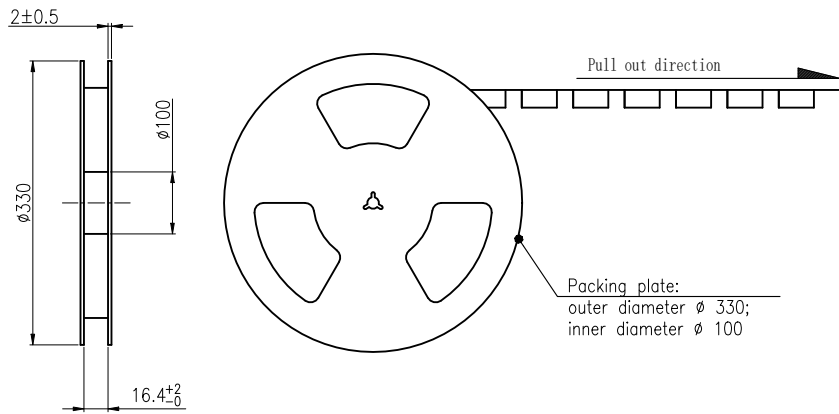
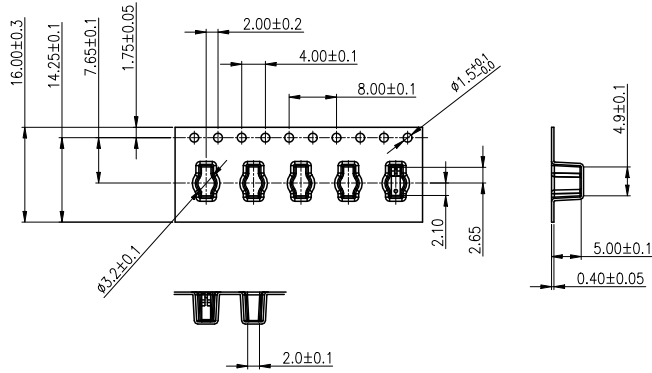

- Remarks:
- Material :
 - Carrier tape:HIPS,T=0.40mm, transparent
 - Packing plate:HIPS,BLUE
 - Upper cover belt: PET, transparent
 - Initial packaging:1500PCS/REEL.
 - Secondary packaging: 14 REEL/box (21000=14*1500/box).
 - Pull out force of upper cover belt: 0.2N~1.2N(20~120gf);
Pull off angle: 165°~180°;
Pull out speed: 300mm/minute.

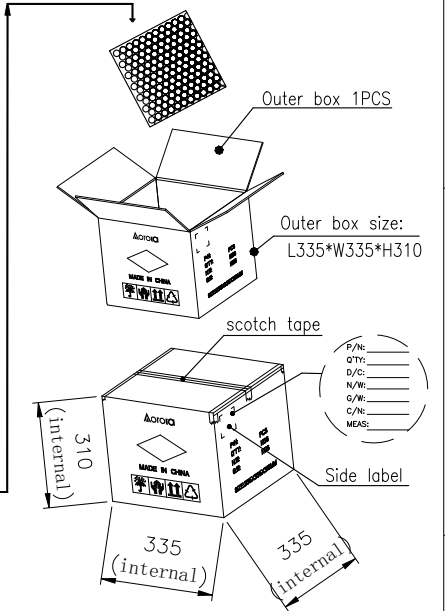

UNLESS OTHERWISE SPECIFIED TOLERANCES				ANGLE OF PROJECTION	
X.	±0.15	X. °	± 1'		
X.X	±0.16	X.X °	± 0.5'		
X.XX	±0.05	X.XX °	± 0.5'	DOC TYPE PACKING DWG.	
X.XXX	±0.03	X.XXX °	± 1'		
LINEAR DIMS		ANGLES DIMS		DRAWN	DATE
DWG NO.: A-H0354				Staven	2020-12-30
MATERIAL		SEE NOTES		DESIGN	DATE
FINISHED		SEE NOTES		Staven	2020-12-30
				CHECKED	DATE
				Biao	2020-12-30
				APPROVED	DATE
				Biao	2020-12-30

 Amphenol Aorora Technology (Huizhou) Co.,Ltd		TITLE:	
		PCB CONTACT SPRING--PACKING	
SIZE	DWG NO.	REV.	
A4	Z02H-4F7L1-11000	A	
SCALE	1:1	UNIT : mm	SHEET 1 OF 1