

REV.	ECR/ECN No.	DESCRIPTION	DRAWN/DATE	CHECKED/DATE	APPROVED/DATE
B		ADD PART NUMBER	Staven 2018-12-18	Peng Li 2018-12-18	Judy 2018-12-18
C	ECN2022112	UPDATE FRAME	Abner 2022-06-21	Staven 2022-06-21	Sam 2022-06-21

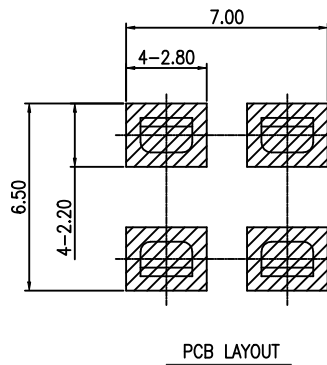
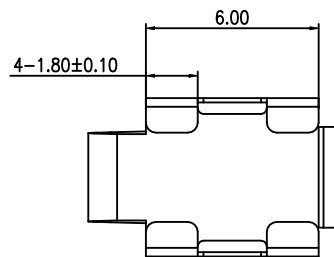
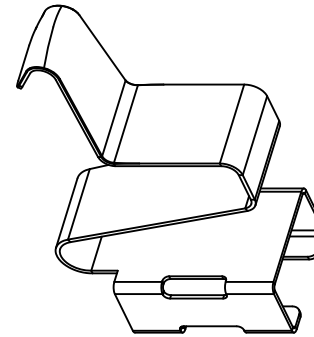
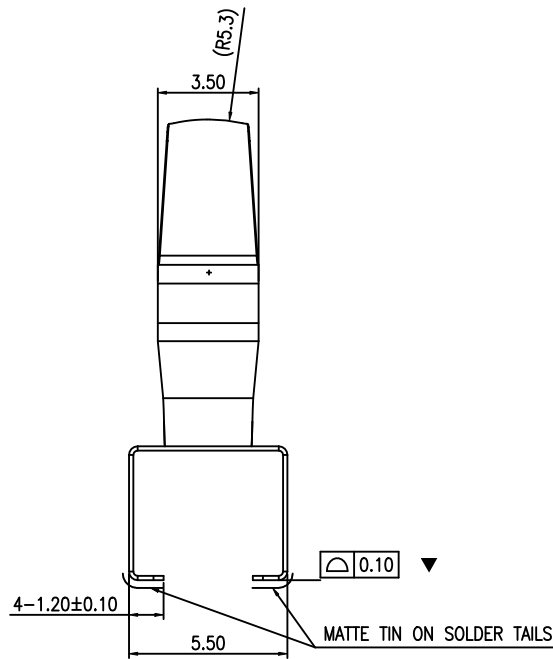
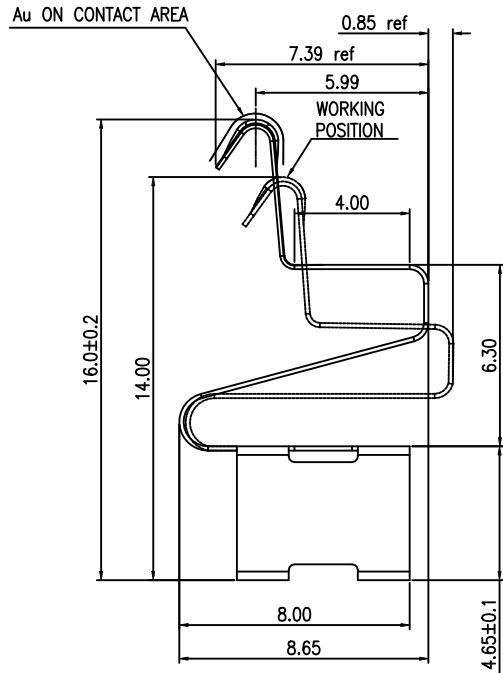

**NOTES:**

1. MATERIAL: SUS 304-H T=0.15mm;
2. BURR: 0.03mm MAX.
3. PLATING: Au 2u" SURFACE PLATING OVER CONTACT AREAS, Tin 100-200u" SURFACE PLATING OVER SOLDER AREAS, Ni 40-120u" UNDER PLATING OVER ALL.
4. ALL MATERIAL MUST BE COMPLY WITH RoHS2.0
5. "▼" MARKED IS CPK & X-R.

UNLESS OTHERWISE SPECIFIED TOLERANCES				ANGLE OF PROJECTION		Amphenol AORORA	
X.	±0.30	X. °	± 5'			Amphenol Aorora Technology (Huizhou) Co.,Ltd	
X.X	±0.25	X.X °	± 4'				
X.XX	±0.20	X.XX °	± 3'	Customer Drw		TITLE: H16mm SPRING	
X.XXX	±0.15	X.XXX °	± 2'	DRAWN	DATE	Abner	2022-06-21
LINEAR DIMS		ANGLES DIMS		DESIGN	DATE	Abner	2022-06-21
DWG NO.: A-S0479				CHECKED	DATE	Staven	2022-06-21
MATERIAL		SEE NOTES		APPROVED	DATE	Sam	2022-06-21
FINISHED		SEE NOTES		SCALE		1:1	UNIT : mm
				SHEET		1	OF 1
				PART NUMBER:		Z01V-4G7L1-11000-E000	REV. C

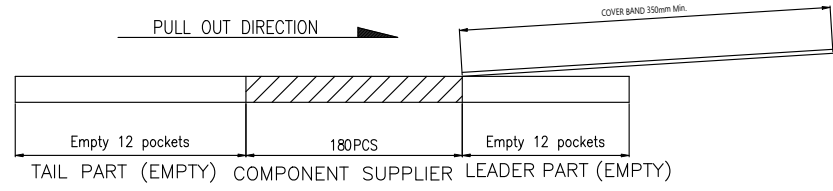
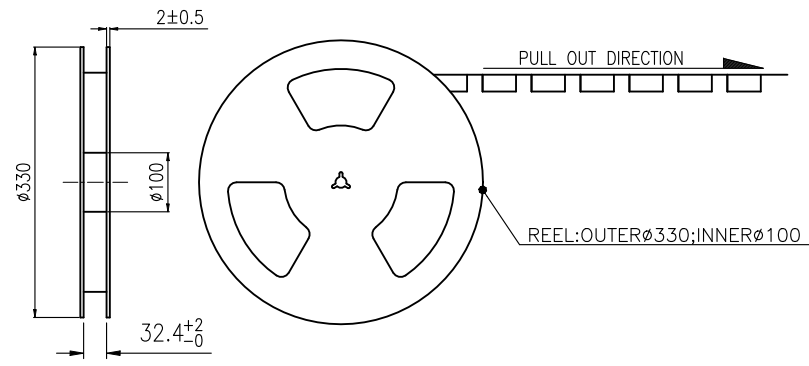
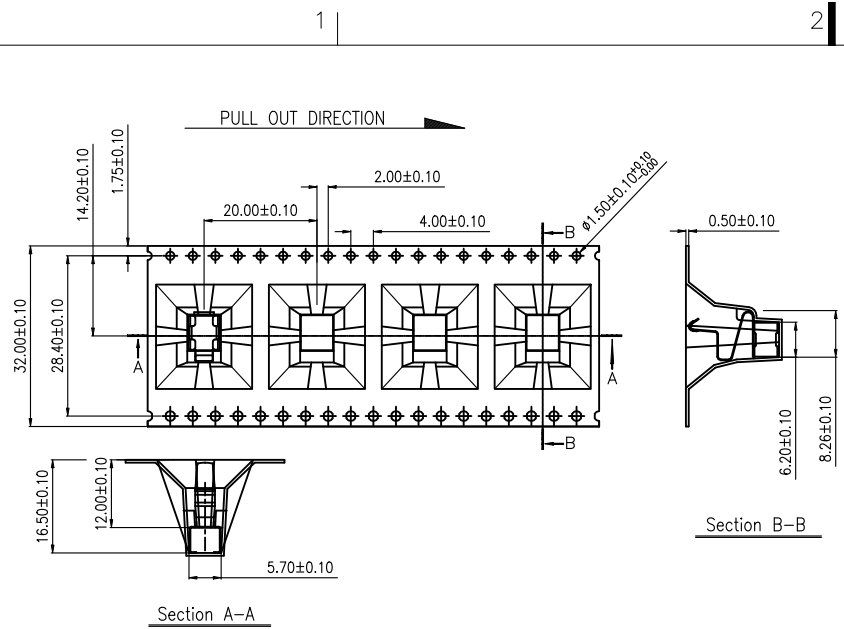

REV.	ECR/ECN No.	DESCRIPTION	DRAWN/DATE	CHECKED/DATE	APPROVED/DATE
B	ECN20190096	Update product direction	Staven 2019-09-16	Biao 2019-09-16	Biao 2019-09-16

- NOTES:
- MATERIAL:
    - CARRY TAPE:HIPS,T=0.50mm, COLOR:TRANSPARENT.
    - REEL:HIPS,BLUE.
    - SHIM:PE,CLEAR.
  - PRIMARY PACKING:180PCS/REEL.
  - SECONDARY PACKING:8 REELS/CARTON ("TOTAL"=8\*180/CARTON).
  - PEELING RESISTANCE: 0.1N~1.2N(10~120gf);  
PEELING ANGLE: 165°~180°;  
PEELING SPEED: 300mm/minutes.

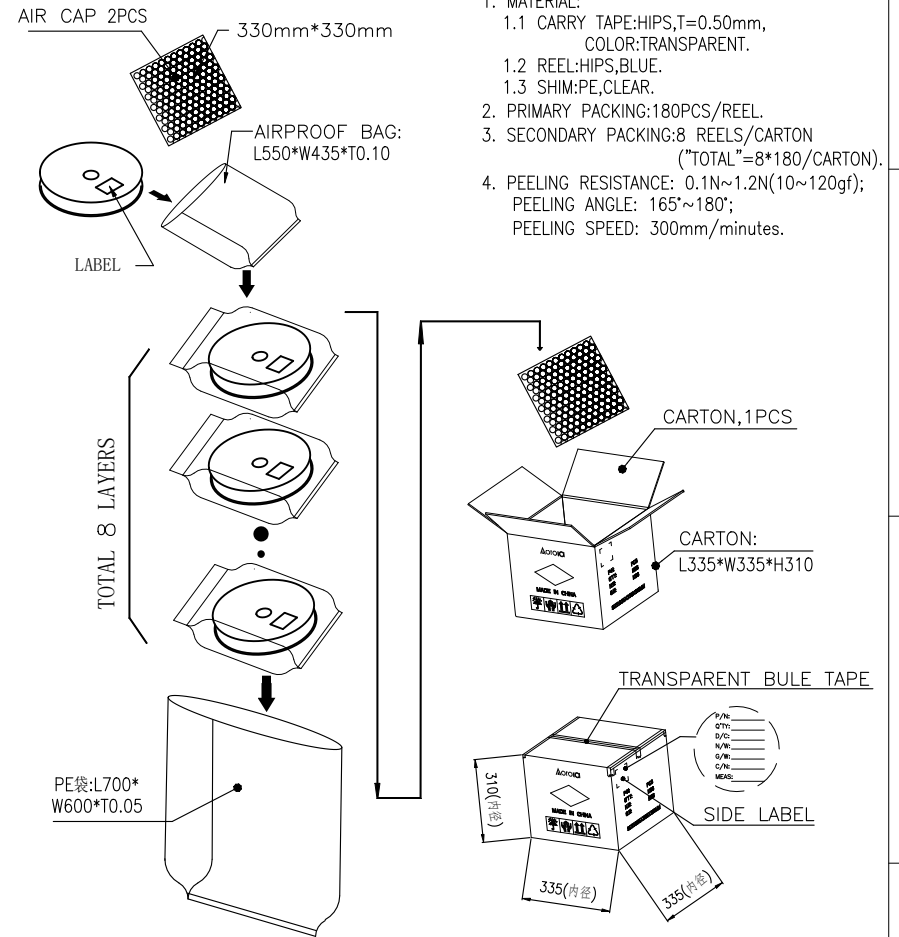

UNLESS OTHERWISE SPECIFIED TOLERANCES				ANGLE OF PROJECTION	
X.	±0.30	X. °	± 2'		
X.X	±0.26	X.X °	± 1'		
X.XX	±0.15	X.XX °	± 0.5'	DOC TYPE: PACKING Drw	
X.XXX	±0.10	X.XXX °	± 1'	DRAWN	DATE: Staven 2019-09-16
LINEAR DIMS		ANGLES DIMS		DESIGN	DATE: Staven 2019-09-16
P/N: A-H0255				CHECKED	DATE: Biao 2019-09-16
MATERIAL: SEE NOTES				APPROVED	DATE: Biao 2019-09-16
FINISHED: SEE NOTES					

		Amphenol Aorora Technology (Huizhou) Co.,Ltd	
		TITLE: H16.0mm SPRING--PACKING	
SIZE: A4	DWG NO. Z01V-4G7L1-11000-E000	REV. B	
SCALE: 1:1	UNIT: mm	SHEET: 1 OF 1	