

1

2

3

4

REV.	ECR/ECN No.	DESCRIPTION	DRAWN/DATE	CHECKED/DATE	APPROVED/DATE
A		NEW RELEASE	Staven 2017-06-03	MuYuan Liu 2017-06-03	Judy 2017-06-03
B	ECN2022081	UPDATE FRAME	Abner 2022-06-14	Staven 2022-06-14	Sam 2022-06-14

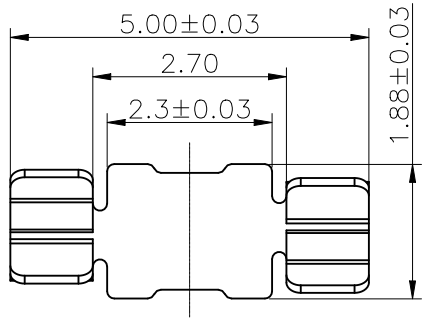
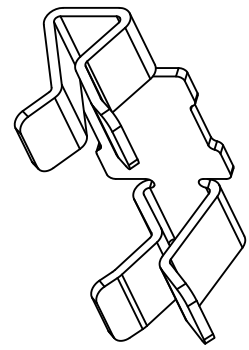

NOTES:

1. MATERIAL: SUS 304 T=0.15mm.
2. FINISH:
Tin 80-200u" SURFACE PLATING OVER ALL.
Ni 40-120u" UNDER PLATING OVER ALL.
3. BURRS: 0.03mm Max.
4. THE SURFACE IS NOT ALLOWED TO HAVE CRUSHING;
SCRATCH;DEFORMATION;DIE MARKS;OIL STAINS.
4. WITH "▼" MUST BE CPK CONTROL.

A

B

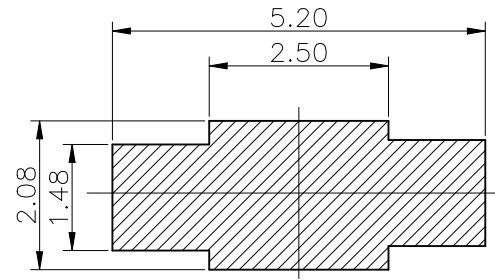
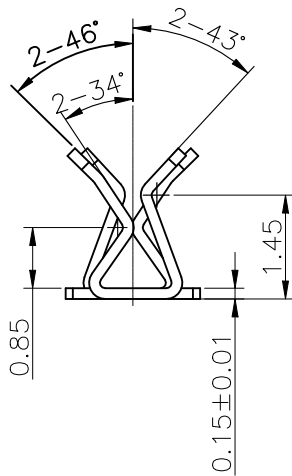
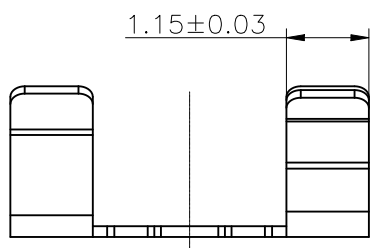
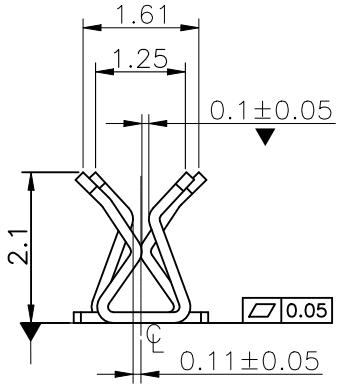

RECOMMEND PCB LAYOUT SIZE



This document is the property of and embodies CONFIDENTIAL and PROPRIETARY information of AOR. No part of the information shown on this document may be used in any way or disclosed to others without the written consent of AOR. © 2019 AOR

UNLESS OTHERWISE SPECIFIED TOLERANCES				ANGLE OF PROJECTION		Amphenol AORORA	
X.	±0.25	X. °	± 5'			Amphenol Aorora Technology (Huizhou) Co.,Ltd	
X.X	±0.20	X.X °	± 3'				
X.XX	±0.10	X.XX °	± 0.2'	DOC TYPE: Customer Drw		TITLE: H2.1 CLIP	
X.XXX	±0.05	X.XXX °	± 0.1'				
LINEAR DIMS		ANGLES DIMS		DRAWN	DATE	Abner	2022-06-14
DWG NO.: A-S0450				DESIGN	DATE	Abner	2022-06-14
MATERIAL		SEE NOTES		CHECKED	DATE	Staven	2022-06-14
FINISHED		SEE NOTES		APPROVED	DATE	Sam	2022-06-14
SIZE	PART NUMBER:		REV.				
A4	Z012-4G7U1-11000-E000		B				
SCALE	1:1	UNIT : mm	SHEET 1 OF 1				

1

2

3

4

REV.	ECR/ECN No.	DESCRIPTION	DRAWN/DATE	CHECKED/DATE	APPROVED/DATE
A		NEW RELEASE	Staven 2017-06-07	MuYuan Liu 2017-06-07	Judy 2017-06-07
B	ECN2022081	UPDATE FRAME	Abner 2022-06-14	Staven 2022-06-14	Sam 2022-06-14

1. PACKING INTO REEL:

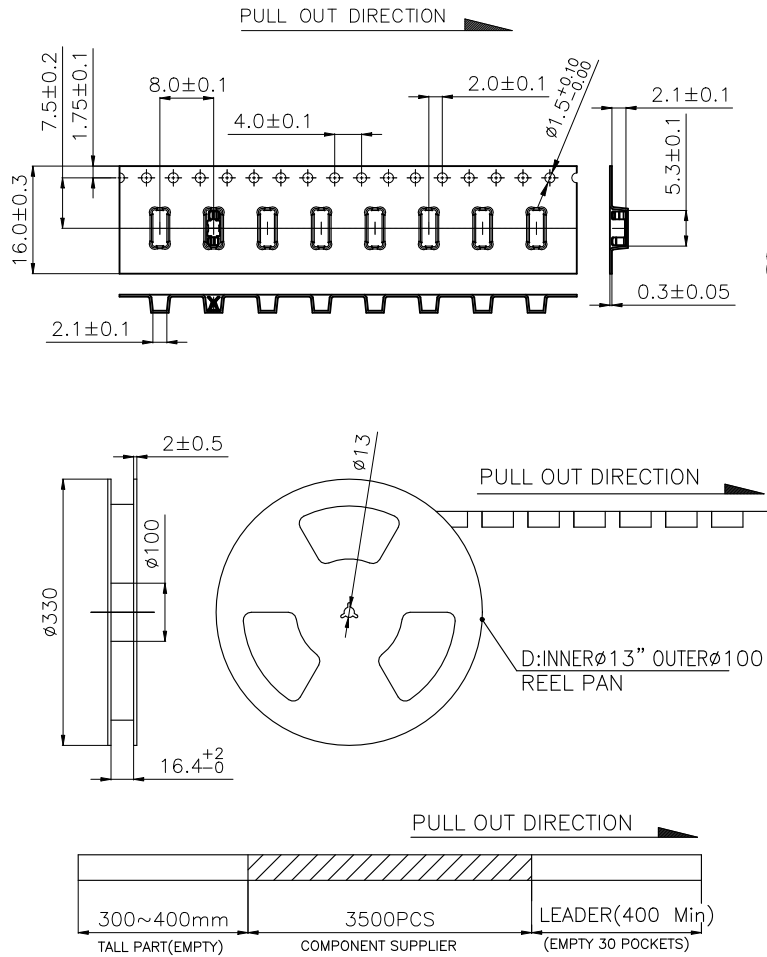

2. PACKING INTO CARTON:

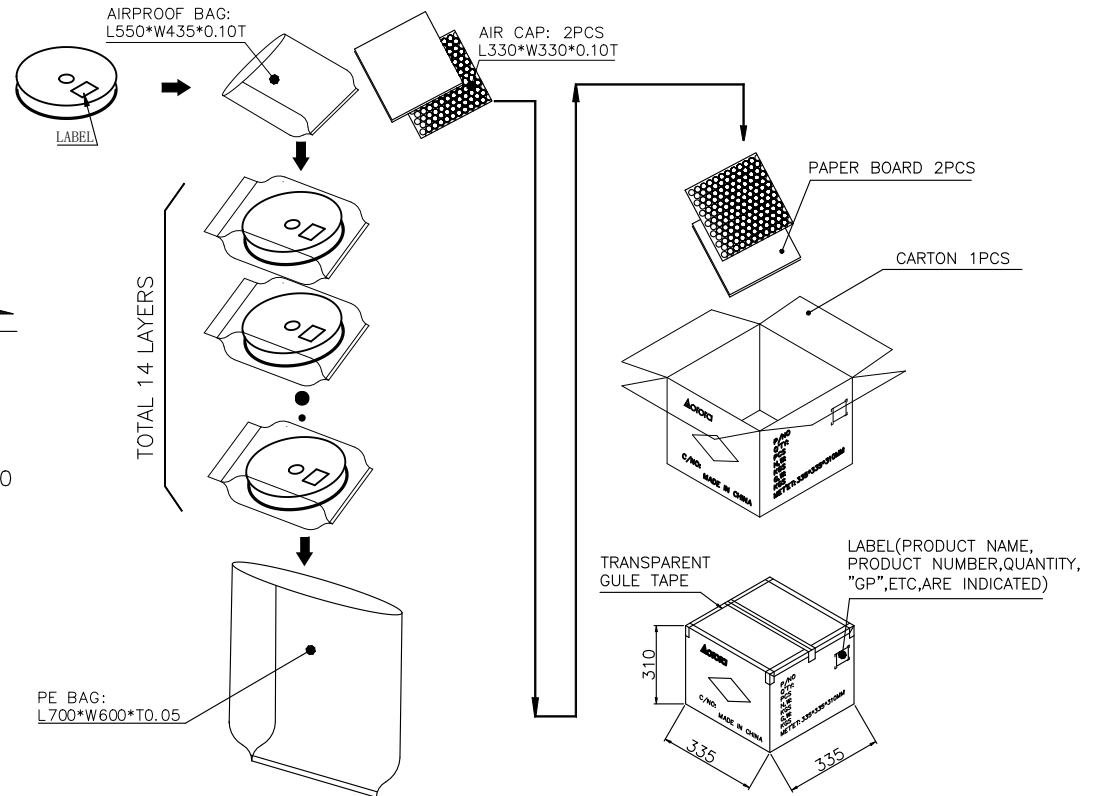

NOTES:

- MATERIAL:
 - CARRY TAPE: PS, T=0.3mm, CLEAR: Transparent.
 - REEL: HIPS, BLUE.
 - SHIM: PE, CLEAR.
- PRIMARY PACKING: 3500PCS/REEL.
- SECONDARY PACKING: 14 REELS/CARTON (49000PCS/CARTON).
- PEELING RESISTANCE: 0.2N~1.2N (20~120gf);
 PEELING ANGLE: 165°~180°;
 PEELING SPEED: 300mm/minutes.

UNLESS OTHERWISE SPECIFIED TOLERANCES				ANGLE OF PROJECTION		Amphenol AORORA	
X.	±0.25	X. *	± 5'			Amphenol Aorora Technology (Huizhou) Co.,Ltd	
X.X	±0.20	X.X *	± 3'				
X.XX	±0.10	X.XX *	± 0.2'	DOC TYPE		TITLE:	
X.XXX	±0.05	X.XXX *	± 0.1'	DRAWN DATE		H2.1 CLIP	
LINEAR DIMS		ANGLES DIMS		DESIGN DATE		PART NUMBER:	
DWG NO.: A-H0252				CHECKED DATE		A4	
MATERIAL		SEE NOTES		APPROVED DATE		Z012-4G7U1-11000-E000	
FINISHED		SEE NOTES		SCALE		REV. B	
				1:1		SHEET 1 OF 1	