

REV.	ECR/ECN No.	DESCRIPTION	DRAWN/DATE	CHECKED/DATE	APPROVED/DATE
C	ECN2022152	UPDATE FRAME	Abner 2022-09-28	Staven 2022-09-28	Sam 2022-09-28

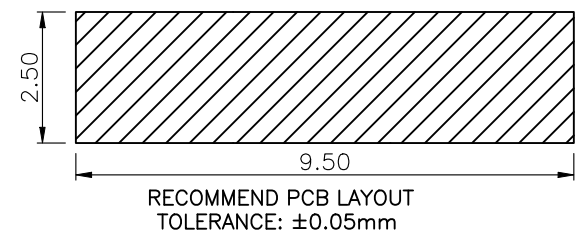
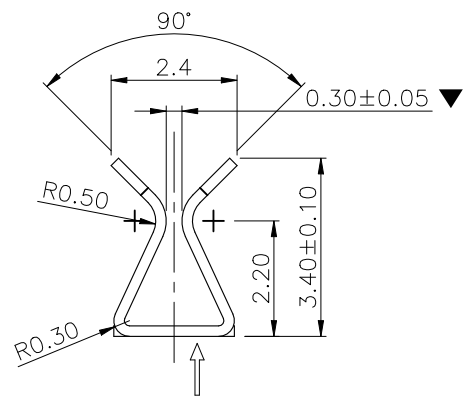
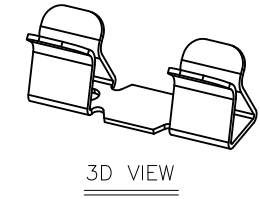
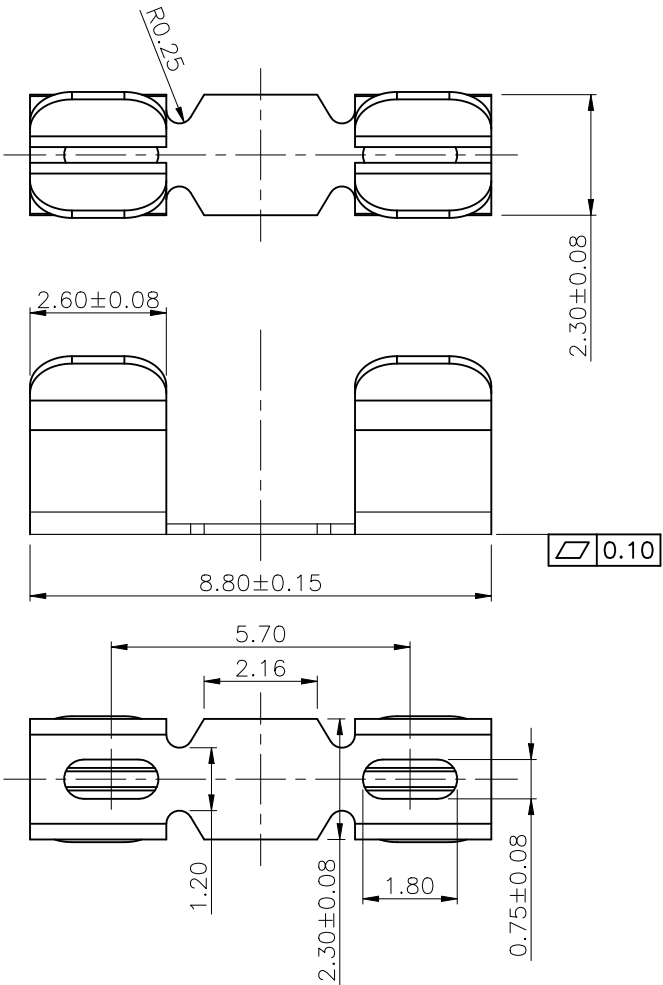

- NOTES:
- MATERIAL: PHOSPHOR BRONZE;
 - FINISH: GOLD FLASH SURFACE PLATING OVER SOLDER AREA, Ni 40-120u" UNDER PLATING OVER ALL.
 - ALL MATERIAL MUST BE COMPLY WITH RoHS2.0;
 - WITH "▼" MUST BE CPK CONTROL.

UNLESS OTHERWISE SPECIFIED TOLERANCES				ANGLE OF PROJECTION		Amphenol AORORA	
X.	±0.30	X. °	± 5'			Amphenol Aorora Technology (Huizhou) Co.,Ltd	
X.X	±0.25	X.X °	± 4'				
X.XX	±0.20	X.XX °	± 3'	Customer Drw		TITLE: H3.4 CLIP	
X.XXX	±0.15	X.XXX °	± 2'	DRAWN	DATE	Deming Li	2016-02-17
LINEAR DIMS		ANGLES DIMS		DESIGN	DATE	Deming Li	2016-02-17
DWG NO.: A-S0310				CHECKED	DATE	Qi Han	2016-02-17
MATERIAL		SEE NOTES		APPROVED	DATE	Hongkui Liu	2016-02-17
FINISHED		SEE NOTES		SCALE		1:1	UNIT: mm
PART NUMBER: Z00U-4B7C1-11000						REV. C	SHEET 1 OF 1

1. PACKING INTO REEL:

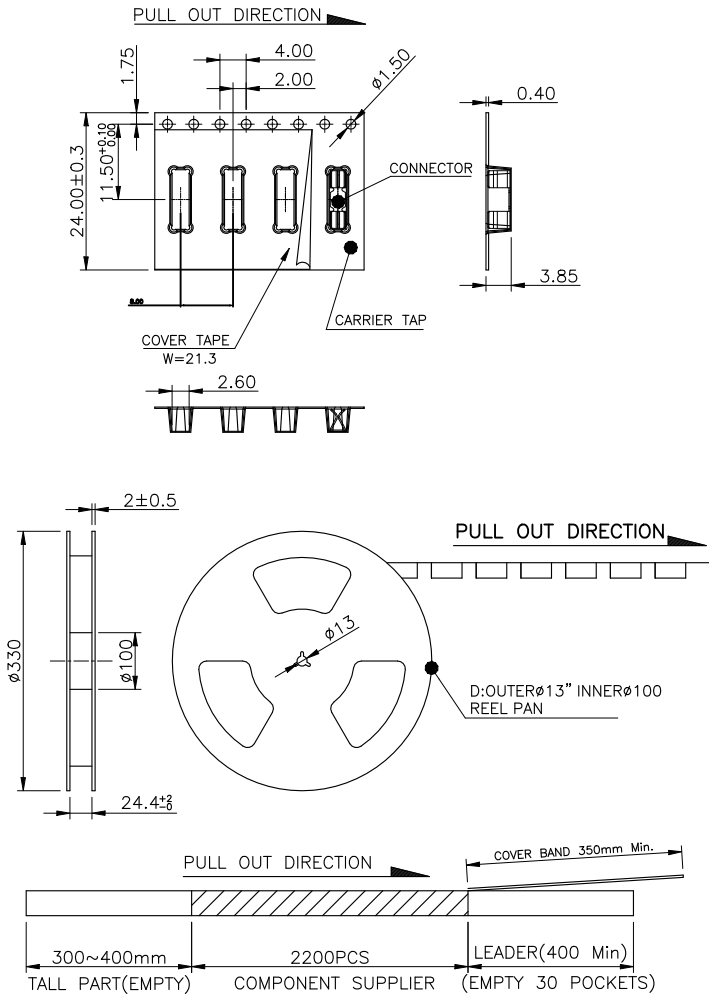

NOTES:

1. MATERIAL:
 - 1.1 CARRY TAPE:PS,T=0.4mm,COLOR:TRANSPARENT.
 - 1.2 REEL:HIPS,BLUE.
 - 1.3 SHIM:PE,CLEAR.
2. PRIMARY PACKING:2200PCS/REEL.
3. SECONDARY PACKING:10REELS/CARTON(22000PCS/CARTON).
4. PEELING RESISTANCE: 0.1N~0.9N(10~90gf);
PEELING ANGLE: 165°~180°;
PEELING SPEED: 300mm/minutes.
5. NET WEIGHT: 0.093g
6. CATON GROSS WEIGHT: 7.4Kg, NET WEIGHT: 2.05Kg

2

2. PACKING INTO CARTON:

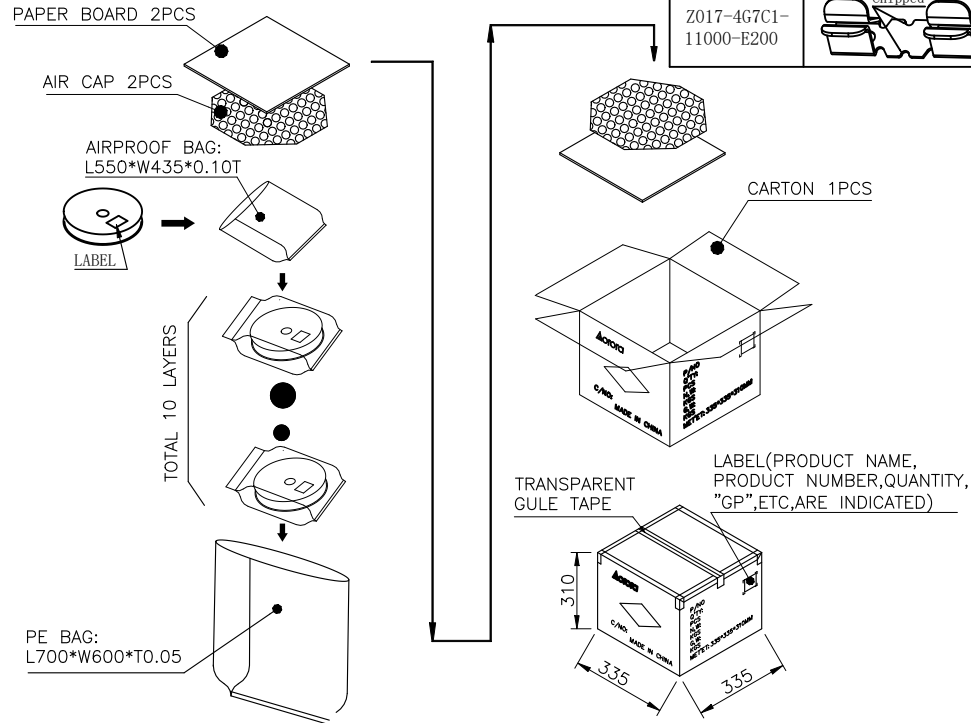

TABLE:

NO.	Sketch Map	Difference
Z002-4B7C1-11000		H3.4 Gap0.1mm
Z00U-4B7C1-11000		H3.4 Gap0.3mm
Z017-4G7C1-11000-E200		H3.4 Gap0.3mm Chipped

REV.	ECR/ECN No.	DESCRIPTION	DRAWN/DATE	CHECKED/DATE	APPROVED/DATE
C		New specifications	Staven 2019-03-04	Peng Li 2019-03-04	Judy 2019-03-04
D		UPDATE FRAME	Abner 2022-05-24	Staven 2022-05-24	Sam 2022-05-24

UNLESS OTHERWISE SPECIFIED TOLERANCES				ANGLE OF PROJECTION		Amphenol AORORA	
X.	±0.30	X. °	± 5'			Amphenol Aorora Technology (Huizhou) Co.,Ltd	
X.X	±0.25	X.X °	± 4'				
X.XX	±0.20	X.XX °	± 3'	DOC Typ Assembly Drw		TITLE: H3.4 CLIP	
X.XXX	±0.15	X.XXX °	± 2'	DRAWN DATE	Abner 2022-05-24	SIZE PART NUMBER:	REV. D
LINEAR DIMS		ANGLES DIMS		DESIGN DATE	Abner 2022-05-24	A4 SEE TABLE	
DWG NO.: A-H0167				CHECKED DATE	Staven 2022-05-24	SCALE	1:1
MATERIAL SEE NOTES				APPROVED DATE	Sam 2022-05-24	UNIT : mm	SHEET 1 OF 1
FINISHED SEE NOTES							

1

2

3

4