

REVISIONS			
REV	DESCRIPTION, ECN, EAR NO.	DATE	APP'D
E	UPDATE THE VIEW AS PER NEW MODEL	MAR08/21	S.M.
F	PRODUCT DWG. REV AS PER EAR 15037	OCT22/21	S.M.
G	PRODUCT DWG. REV AS PER EAR 15100	MAY17/22	S.M.

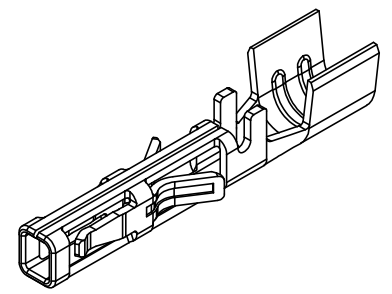
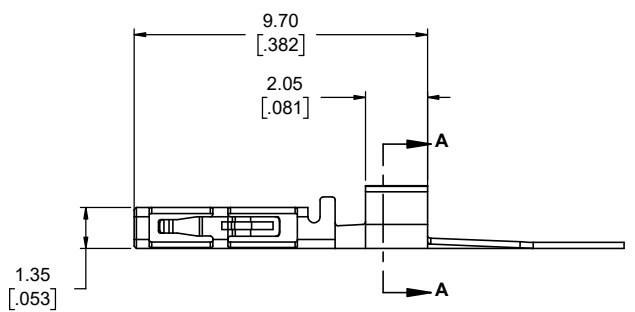
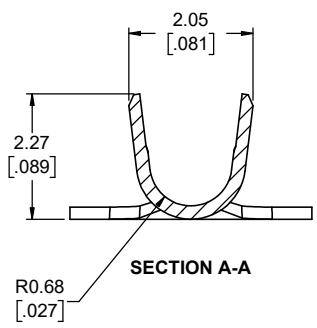
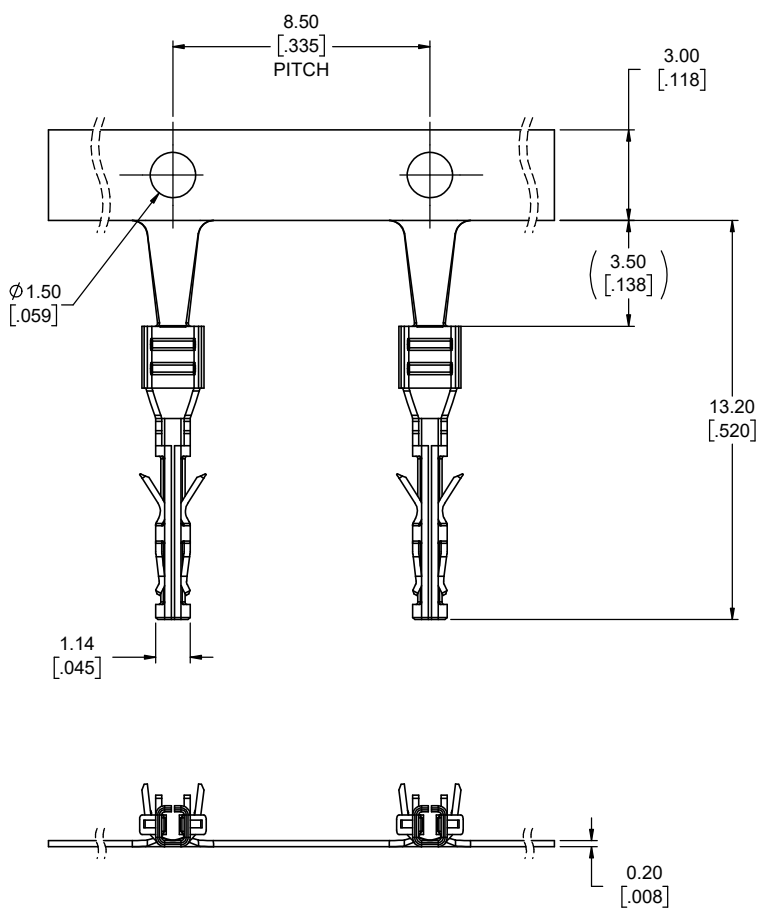

**CONTACT WITHOUT CARRIER**

**ORDERING CODE: FLH - SC136 - XXX**

**CONTACT FINISH**

- T01 = 100µ" TIN
- G15 = 15µ" GOLD
- G30 = 30µ" GOLD

**NOTES:**

1. MATERIALS: ALL MATERIALS ARE RoHS COMPLIANT PER EU DIRECTIVE 2011/65/EU & AMENDMENTS
  - CONTACTS: PHOSPHOR BRONZE PLATED WITH NICKEL UNDER PLATE ALL OVER. MATING AREA PLATED WITH MATTE TIN OR GOLD AS DEFINED BY THE PART NUMBER SELECTED.
2. ELECTRICAL CHARACTERISTICS
  - CURRENT RATING: 7A (18 AWG) OR 5A (20 AWG) OR 3A (22 AWG) PER CONTACT
  - MAXIMUM INSULATION DIAMETER 1.8 MM
  - OPERATING TEMPERATURE: -40°C TO +105°C
3. CONTACT DESIGNED FOR SOCKET CONNECTOR P/N: FLH-SX1-00



UNLESS SPECIFIED OTHERWISE	DRAWN	B.COPPING	NOV30/18
PRIMARY UNITS MILLIMETERS	CHECKED	S.MUGAN	NOV30/18
SECONDARY INCHES	M.E. APP'D		
REFERENCE IN PARENTHESSES	Q.A. APP'D		
GENERAL TOLERANCES	DWG APPR.		
1 DECIMAL PLACE	ENG. REL. NO.		
2 DECIMAL PLACES ±0.20	REF.		
3 DECIMAL PLACES	THIRD ANGLE PROJECTION		
ANGULAR DEGREES	DO NOT SCALE DRAWING		

**Amphenol Canada Corp.**  
Commercial Products

**FLH SERIES, 2.5mm PITCH SOCKET CONTACT, CRIMP TERMINATION, RoHS COMPLIANT**

DWG. NO. **P-FLH-SC136-XXX** REV **G**

CODE ID NO. 03554 DWG SIZE: X SCALE: 2:1 SHEET 1 OF 2

REVISIONS			
REV	DESCRIPTION, ECN, EAR NO.	DATE	APP'D
E	UPDATE THE VIEW AS PER NEW MODEL	MAR08/21	S.M.
F	PRODUCT DWG. REV. AS PER EAR 15037	OCT22/21	S.M.
G	PRODUCT DWG. REV. AS PER EAR 15100	MAY17/22	S.M.

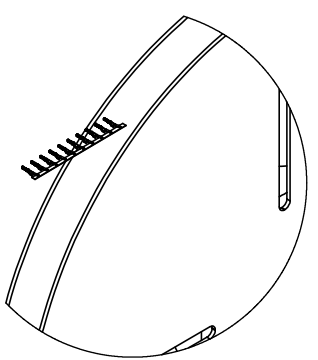

**DETAIL C**  
SCALE 2 : 5

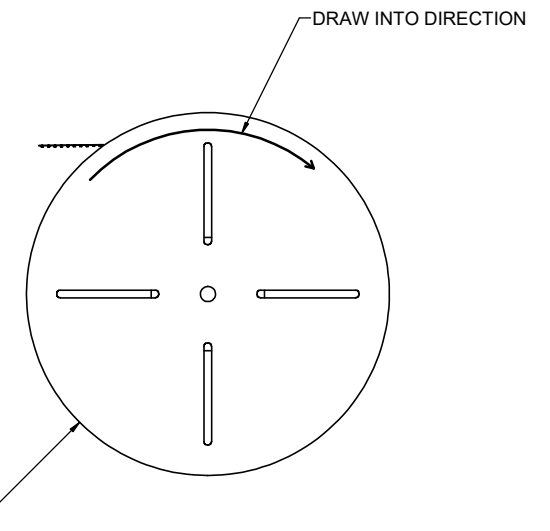
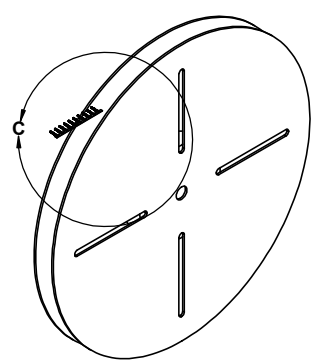

PACKAGING: FLH-SC136-XXX 5000PCS PER REEL.



UNLESS SPECIFIED OTHERWISE	DRAWN	B.COPPING	NOV30/18
PRIMARY UNITS MILLIMETERS	CHECKED	S.MUGAN	NOV30/18
SECONDARY INCHES	M.E. APP'D		
REFERENCE IN PARENTHESES	Q.A. APP'D		
GENERAL TOLERANCES	DWG APPR.		
1 DECIMAL PLACE	ENG. REL. NO.		
2 DECIMAL PLACES ±0.20	REF.		
3 DECIMAL PLACES	THIRD ANGLE PROJECTION		
ANGULAR DEGREES	DO NOT SCALE DRAWING		

**Amphenol Canada Corp.**  
Commercial Products

FLH SERIES, 2.5mm PITCH  
SOCKET CONTACT, CRIMP  
TERMINATION, RoHS COMPLIANT

DWG. NO. **P-FLH-SC136-XXX** REV **G**

CODE ID NO. 03554 | DWG SIZE: X | SCALE: 1:5 | SHEET 2 OF 2