

REVISIONS			
REV	DESCRIPTION, ECN, EAR NO.	DATE	APP'D
G	PRODUCT DWG. REV. AS PER EAR 15036	OCT22/21	S.M.
H	PRODUCT DWG. REV. AS PER EAR 15100	MAY03/22	S.M.

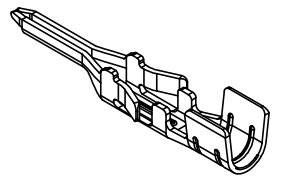
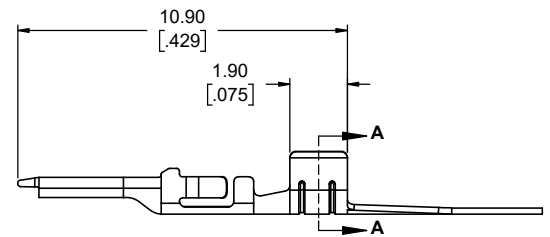
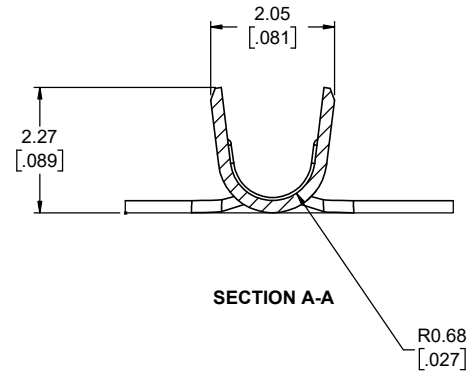
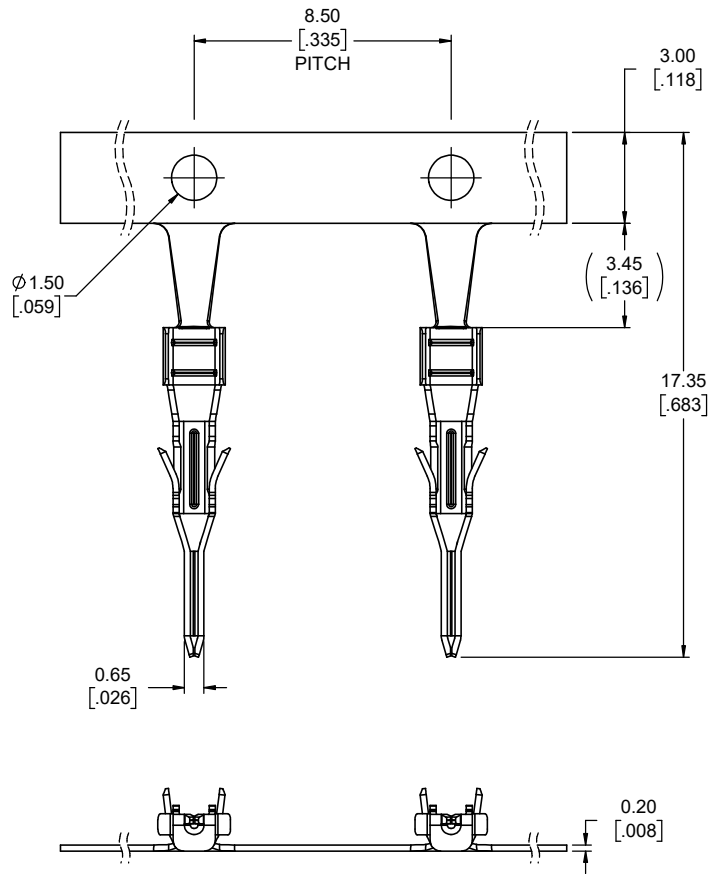

CONTACT WITHOUT CARRIER

ORDERING CODE: FLH - PC136 - XXX

CONTACT FINISH

- T01 = 100µ" TIN
- G15 = 15µ" GOLD
- G30 = 30µ" GOLD

NOTES:

1. MATERIALS: ALL MATERIALS ARE RoHS COMPLIANT PER EU DIRECTIVE 2011/65/EU & AMENDMENTS
 - CONTACTS: PHOSPHOR BRONZE PLATED WITH NICKEL UNDER PLATE ALL OVER. MATING AREA PLATED WITH MATTE TIN OR GOLD AS DEFINED BY THE PART NUMBER SELECTED.
2. ELECTRICAL CHARACTERISTICS
 - CURRENT RATING: 7A (18 AWG) OR 5A (20 AWG) OR 3A (22 AWG) PER CONTACT
 - MAXIMUM INSULATION DIAMETER 1.8 MM
 - OPERATING TEMPERATURE: -40°C TO +105°C
3. CONTACT DESIGNED FOR PIN CONNECTOR P/N: FLH-PX1-00



UNLESS SPECIFIED OTHERWISE	DRAWN	B.COPPING	NOV13/18
PRIMARY UNITS MILLIMETERS	CHECKED	S.MUGAN	NOV30/18
SECONDARY INCHES	M.E. APP'D		
REFERENCE IN PARENTHESES	Q.A. APP'D		
GENERAL TOLERANCES	DWG APPR.		
1 DECIMAL PLACE	ENG. REL. NO.		
2 DECIMAL PLACES ±0.20	REF.		
3 DECIMAL PLACES	THIRD ANGLE PROJECTION		
ANGULAR DEGREES	DO NOT SCALE DRAWING		

Amphenol Canada Corp.
Commercial Products

FLH SERIES, 2.5mm PITCH PIN CONTACT, CRIMP TERMINATION, RoHS COMPLIANT

DWG. NO. **P-FLH-PC136-XXX** REV **H**

CODE ID NO. 03554 DWG SIZE: X SCALE: 1:1 SHEET 1 OF 2

REVISIONS			
REV	DESCRIPTION, ECN, EAR NO.	DATE	APP'D
G	PRODUCT DWG. REV. AS PER EAR 15036	OCT22/21	S.M.
H	PRODUCT DWG. REV. AS PER EAR 15100	MAY03/22	S.M.

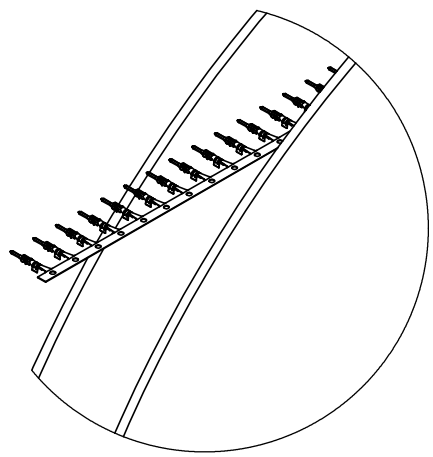

DETAIL A
SCALE 1 : 1

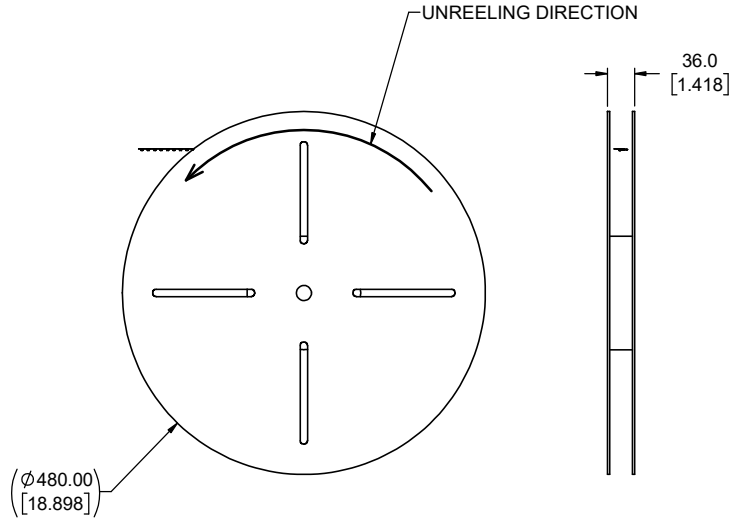
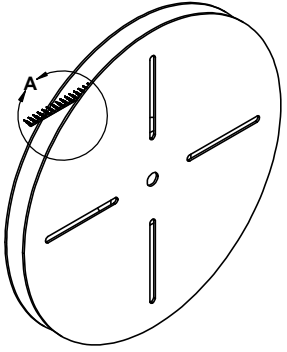

PACKAGING NOTES:

1. EACH REEL SHALL CONTAIN 5000 CONTACTS
2. EACH CARTON SHALL CONTAIN 4 REELS FOR A TOTAL OF 20,000 CONTACTS



UNLESS SPECIFIED OTHERWISE	DRAWN	B.COPPING	NOV30/18
PRIMARY UNITS MILLIMETERS	CHECKED	S.MUGAN	NOV30/18
SECONDARY INCHES	M.E. APP'D		
REFERENCE IN PARENTHESES	Q.A. APP'D		
GENERAL TOLERANCES	DWG APPR.		
1 DECIMAL PLACE	ENG. REL. NO.		
2 DECIMAL PLACES ±0.20	REF.		
3 DECIMAL PLACES	THIRD ANGLE PROJECTION		
ANGULAR DEGREES	DO NOT SCALE DRAWING		

Amphenol Canada Corp.
Commercial Products

FLH SERIES, 2.5mm PITCH PIN CONTACT, CRIMP TERMINATION, RoHS COMPLIANT

DWG. NO. **P-FLH-PC136-XXX** REV **H**

CODE ID NO. 03554 | DWG SIZE: X | SCALE: 1:5 | SHEET 2 OF 2