

FLH-CT-S-02 APPLICATOR

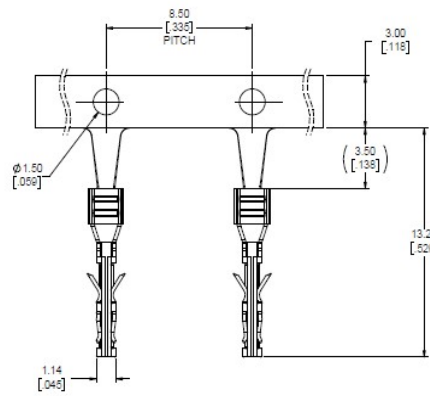

SOCKET CONTACT FLH-SC136-T01

REVISIONS			
REV	DESCRIPTION, ECN, EAR NO.	DATE	APP'D
A	INITIAL RELEASE	FEB04/21	S.M
B	PROPOSAL DWG. REV. PER EAR 15148	JUN30/22	S.M



FLH-CT-0-02 CRIMP MACHINE WITH APPLICATOR

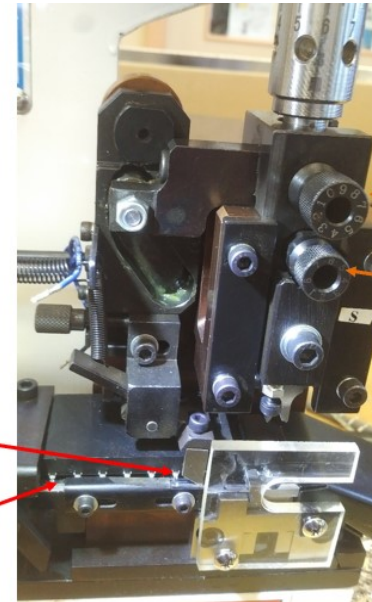

Wire crimp adjuster
Pull and rotate to make adjustments

Insulation crimp adjuster
Pull and rotate to make adjustments

IMPORTANT
Only wire and insulator adjustments are made, and nothing else

Contact Index
Contact

NOTES:

1. CRIMP SOCKET APPLICATOR SHOULD BE USED WITH FLH-CT-0-02 CRIMP MACHINE OR ADOPTED TO OTHER CRIMPING MACHINES
2. CRIMP TOOL IS INCLUDED WITH THE APPLICATOR
3. SOCKET CONTACT, FLH-SC136-T01 IN REEL ONLY TO BE USED WITH THIS APPLICATOR
4. PLEASE REFER TO APPLICATION SPECIFICATION NO. S 6147C
5. FOR ORDERING INFORMATION PLEASE CONTACT THE AMPHENOL REPRESENTATIVE



AMPHENOL PART No. FLH-CT-S-02

UNLESS SPECIFIED OTHERWISE	DRAWN	S.MUGAN	FEB04/21
PRIMARY UNITS MILLIMETERS	CHECKED		
SECONDARY	M.E. APP'D		
REFERENCE IN PARENTHESES	Q.A. APP'D		
GENERAL TOLERANCES	DWG APPR.		
1 DECIMAL PLACE	ENG. REL. NO.		
2 DECIMAL PLACES	REF.		
3 DECIMAL PLACES	THIRD ANGLE PROJECTION		
ANGULAR DEGREES	DO NOT SCALE DRAWING		

Ampenol Canada Corp. Commercial Products	
FLH SOCKET CRIMP APPLICATOR SEMI-AUTOMATIC	
DWG. NO.	REV
P-FLH-CT-S-02	B
CODE ID NO. 03554	DWG SIZE: X
SCALE: 5:1	SHEET 1 OF 1