

REVISIONS			
REV	DESCRIPTION	DATE	APPV
A	PRODUCTION RELEASE	BMURPHY 11/06/13	SAH

D
C
B
A

D
C
B
A

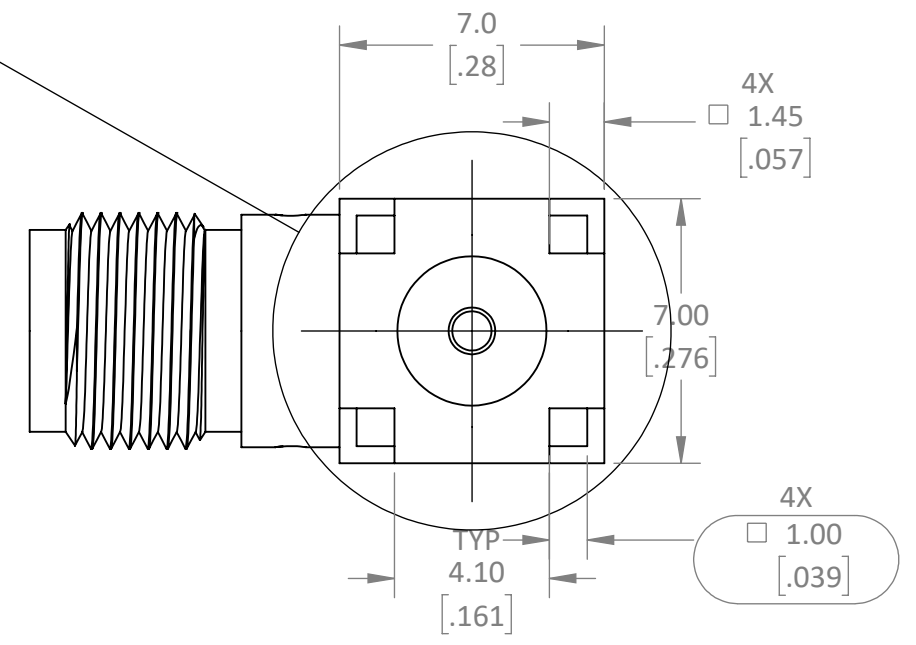
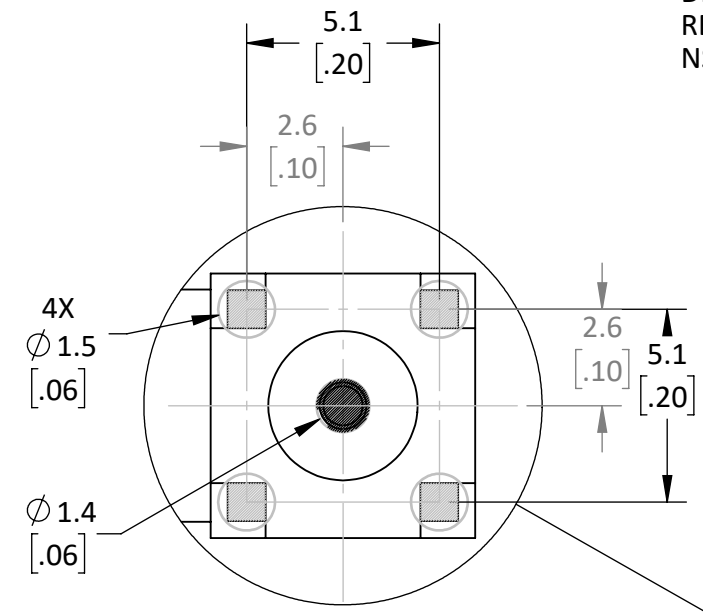
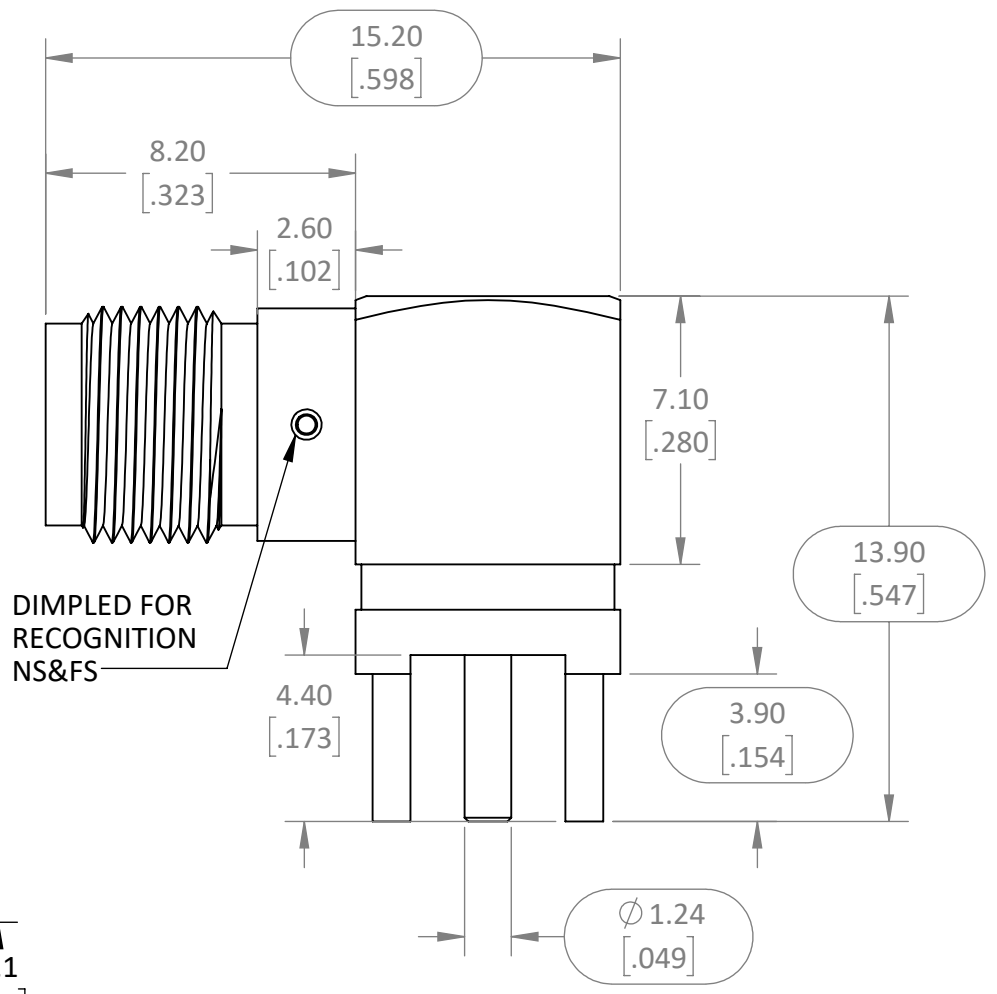

- ALL DIMENSIONS ARE IN MILLIMETERS [IN].
- DIMENSIONS APPLY AFTER FINISHING.
- MANUFACTURE TO BE COMPLIANT WITH EU RoHS DIRECTIVE, USE MATERIALS THAT DO NOT CONTAIN REACH SUBSTANCES OF VERY HIGH CONCERN >1000ppm, AND USE DRC CONFLICT-FREE SOURCED MATERIALS.
- ELECTRICAL PROPERTIES ARE SHOWN FOR REFERENCE ONLY. SEE DATA SHEET FOR COMPLETE LIST OF SPECIFICATIONS.
 - FREQUENCY: 0-6GHz
 - INSERTION LOSS: NTE .075xvf(GHz)
 - IMPEDANCE: 50Ω
- PRODUCT TESTED IAW INTERNAL TEST PLAN AT LATEST REVISION.
- UNLISTED DIMENSIONS ARE CONTROLLED BY SOLID MODEL AT LATEST REVISION.
- MECHANICAL:
 - OPERATING TEMPERATURE: -40° - 85°C
 - STORAGE TEMPERATURE: -40° - 85°C
 - MAX TORQUE: .57Nm [5in/Lbs]
 - INTERCONNECT: SMA STYLE [IAW MIL-STD-348B]
- PACKAGE PER PURCHASE ORDER AND LABEL LOT BAGS IAW LABEL DRAWING PROVIDED.

WARNING: THIS DRAWING CONTAINS PROPRIETARY INFORMATION THAT IS THE SOLE PROPERTY OF LINX TECHNOLOGIES, AND SHALL BE TREATED AS SUCH. NO DISCLOSURE OR REPRODUCTION OF THIS DOCUMENT IS PERMITTED, IN WHOLE OR IN PART, WITHOUT THE EXPRESS WRITTEN PERMISSION OF LINX TECHNOLOGIES OR ITS DESIGNATED AGENTS.



MATERIAL: BRASS, BeCu PTFE	INTERPRET DIMENSIONS AND TOLERANCES PER ASME Y14.5. .X ±.5 .XX ±.20 .XXX ±.100	ANGLES: ±1° SURFACE: √	PROJECTION:
WEIGHT:	DRAWN: B.MURPHY	DT: 2-APR-13	
FINISH: GOLD	ENGR: SHOGAN	DT: 11-JUN-13	

TITLE: SOLID MODEL, APPROVED FOR CUSTOMER USE		
SIZE B	DWG. NO. C-CON SMA002-G	REV A
SCALE: 5:1	DO NOT SCALE DRAWING	SHEET 1 OF 1