

DO NOT SCALE FROM THIS PRINT

QSS-XXX-XX-XX-D-RA-WT-XXX

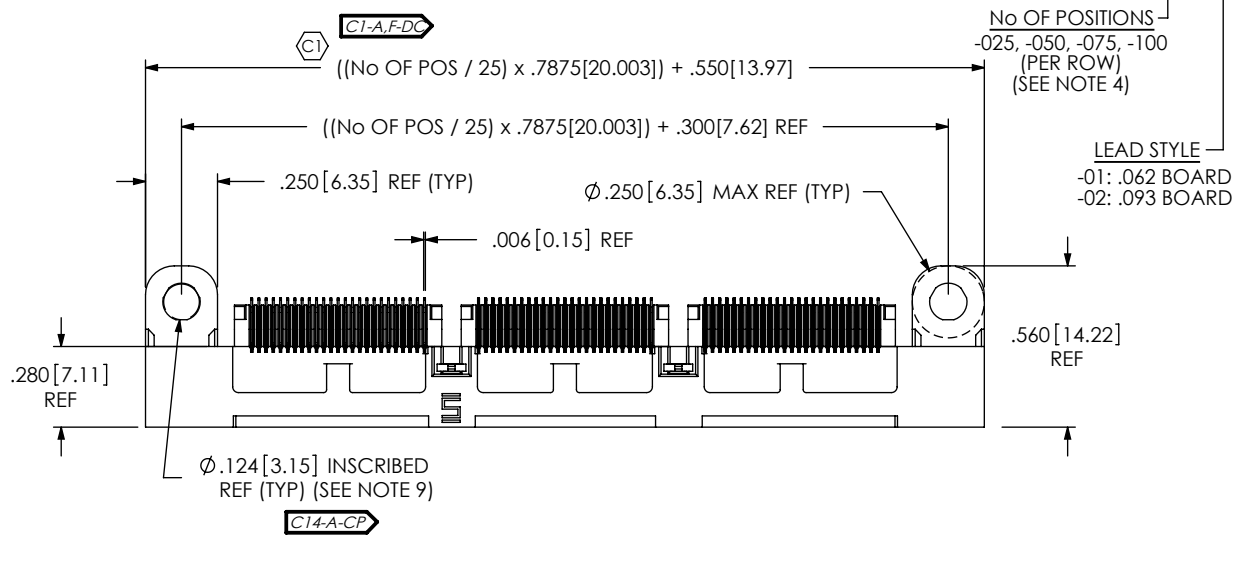

- OPTION
- LS1: LOCKING SCREW (SEE FIG. 2, SHT 3) (FOR MATING WITH QTS-...-RA-..LS1)
 - MTI: THREADED INSERT (SEE FIG. 5, SHT 5)
 - SP: SOLDER PIN (NOT AVAILABLE W/LS1 OPTION) (USE SP-19-T) (SEE FIG. 3, SHT 4)
 - K: KAPTON PAD (SEE FIG. 4, SHEET 4) (USE K-500-300)
- WT: WELD TAB
N/A ON 25 POSITION
- RA: RIGHT ANGLE
- ROW SPECIFICATION
-D: DOUBLE (USE QSS-25-01-D-XX-RA)
- PLATING SPECIFICATION
SEE TABLE 2

FIG. 1
QSS-075-01-XX-D-RA SHOWN

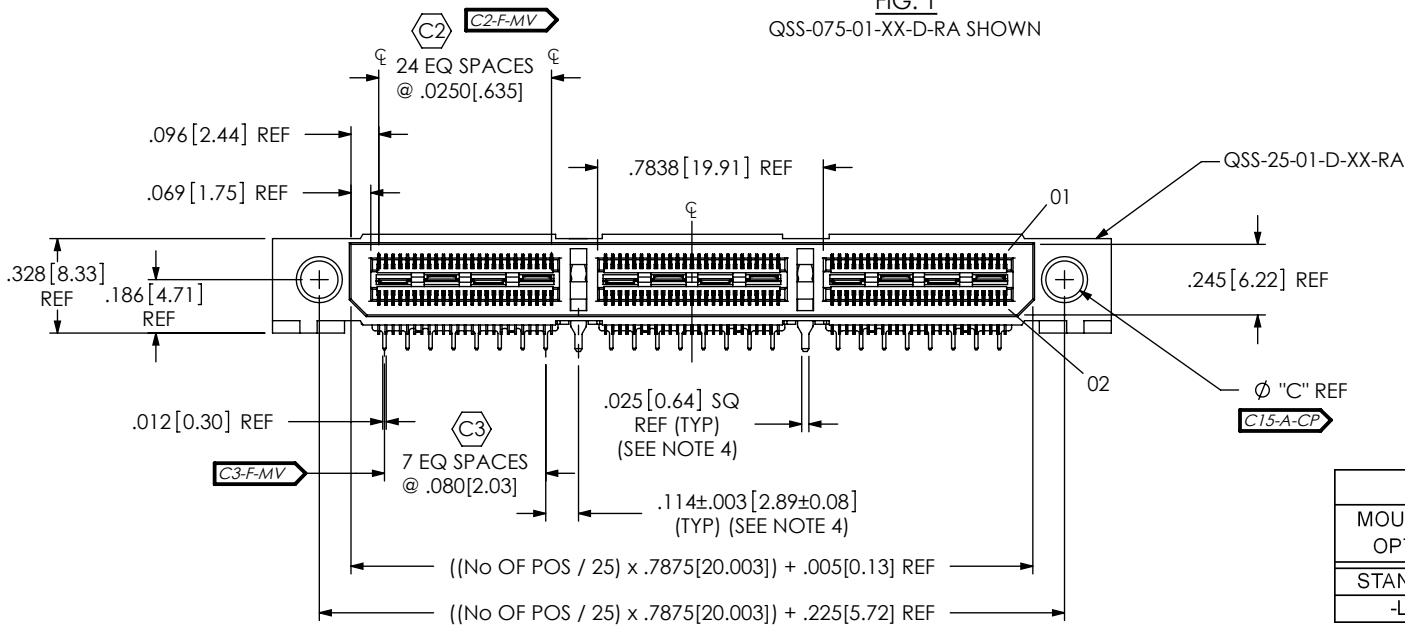

TABLE 4

MOUNTING OPTION	"C" HOLE DIA
STANDARD	.130[3.30]
-LS1	.0625[1.588]

- NOTES:
1. Ⓢ REPRESENTS A CRITICAL DIMENSION.
 2. BURR ALLOWANCE: .0010 MAX.
 3. MINIMUM PUSHOUT FORCE: 6 OZ.
 4. WELD TABS (WT-16-XX-T) NOT AVAILABLE ON -025 POSITION.
 5. IF NEEDED, -L PLATING CAN BE SUBSTITUTED FOR -F PLATING.
 6. IM-1G18-XX-1-XX RETENTION TO BE 1.0 LBS. MINIMUM PRIOR TO SECOND ROW FILL.
 7. DESIGNED FOR USE WITH A .062 OR .093 THICK PCB
 8. ASSEMBLIES TO BE PACKAGED IN TRAYS.
 9. RECOMMENDED TORQUE ON HOLD DOWN SCREWS TO BE 20 IN-OZ +/- 5 IN-OZ.

<p>UNLESS OTHERWISE SPECIFIED, DIMENSIONS ARE IN INCHES. TOLERANCES ARE:</p> <p>DECIMALS ANGLES</p> <p>.XX: ±.01 [.3] 2°</p> <p>.XXX: ±.005 [.13]</p> <p>.XXXX: ±.0020 [.051]</p>	<p>PROPRIETARY NOTE</p> <p>THIS DOCUMENT CONTAINS INFORMATION CONFIDENTIAL AND PROPRIETARY TO SAMTEC, INC. AND SHALL NOT BE REPRODUCED OR TRANSFERRED TO OTHER DOCUMENTS OR DISCLOSED TO OTHERS OR USED FOR ANY PURPOSE OTHER THAN THAT WHICH IT WAS OBTAINED WITHOUT THE EXPRESSED WRITTEN CONSENT OF SAMTEC, INC.</p>	<p>520 PARK EAST BLVD. NEW ALBANY, IN 47150 PHONE: 812-944-6733 FAX: 812-948-5047 e-Mail: info@SAMTEC.com code: 53322</p>

TABLE 3				
LEAD STYLE	"A"	"B"	IM-1G18-XX-1-X	WT-16-XX-T
-01	.064[1.63]	.058[1.47]	IM-1G18-01-1-XX	WT-16-02-T
-02	.125[3.18]	.125[3.18]	IM-1G18-02-1-XX	WT-16-04-T

TABLE 1	
No OF POSITIONS	COPLANARITY
-025 THRU -075	.004[0.10]
-100	.006[0.15]

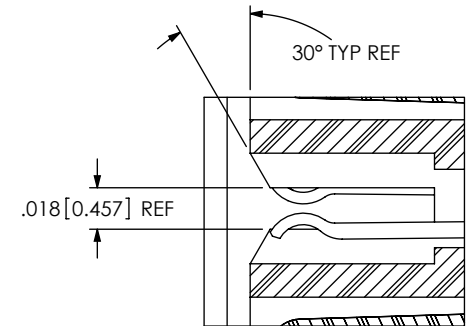
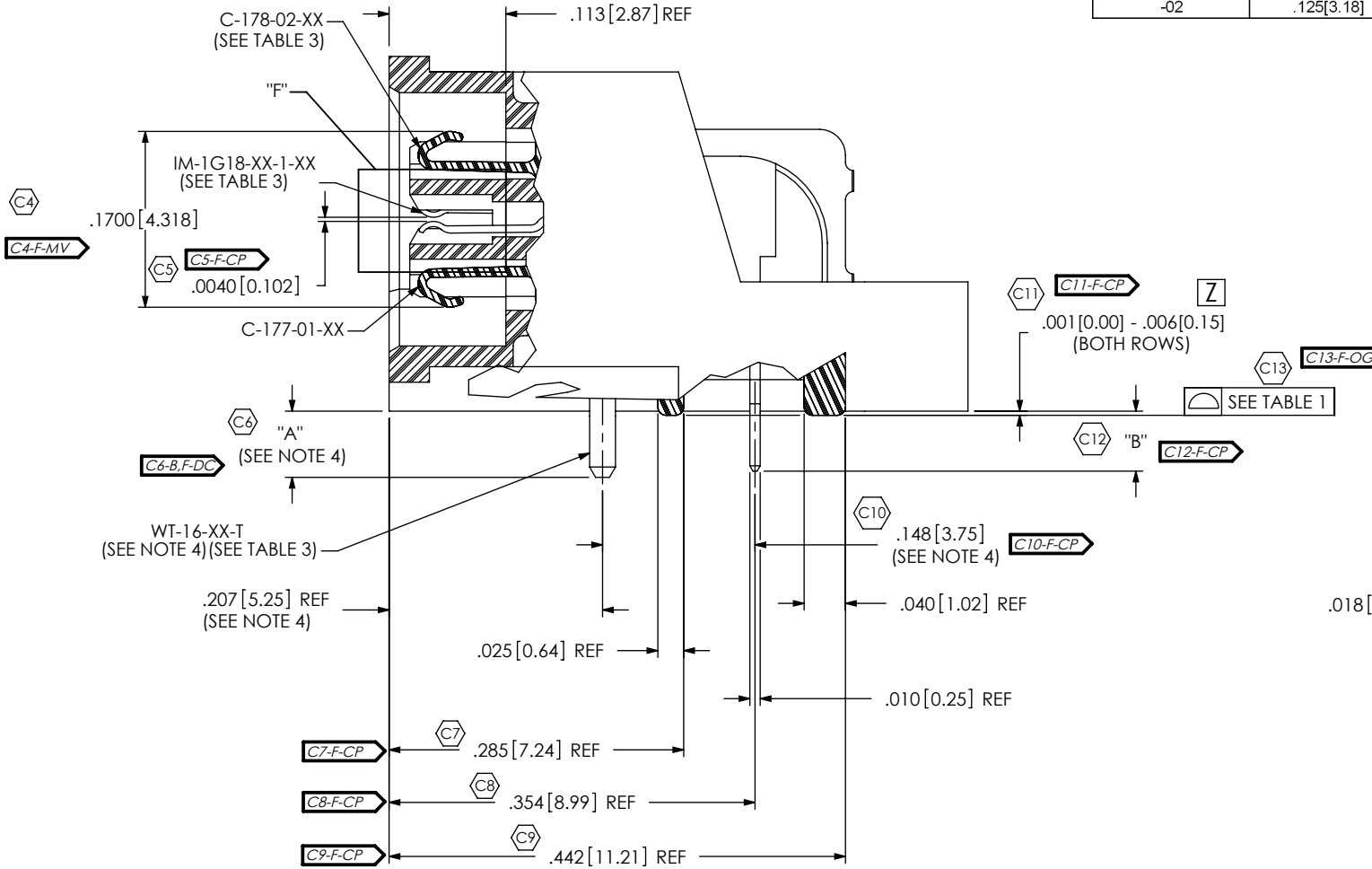



TABLE 2: PLATING SPECIFICATIONS

	CONTACT	CONTACT	GROUND PLANE	WELD TAB
-F	C-177-01-F FLASH GOLD CONTACT, MATTE TIN TAIL	C-178-02-F FLASH GOLD CONTACT, MATTE TIN TAIL	IM-1G18-XX-F FLASH GOLD CONTACT, MATTE TIN TAIL	WT-16-XX-T MATTE TIN ALL OVER
-L	C-177-01-L LIGHT GOLD CONTACT, MATTE TIN TAIL	C-178-02-L LIGHT GOLD CONTACT, MATTE TIN TAIL	IM-1G18-XX-L LIGHT GOLD CONTACT, MATTE TIN TAIL	WT-16-XX-T MATTE TIN ALL OVER
-H	C-177-01-H HEAVY GOLD CONTACT, FLASH GOLD TAIL	C-178-02-H HEAVY GOLD CONTACT, FLASH GOLD TAIL	IM-1G18-XX-L LIGHT GOLD CONTACT, MATTE TIN TAIL	WT-16-XX-T MATTE TIN ALL OVER
-FM	C-177-01-F FLASH GOLD CONTACT, MATTE TIN TAIL	C-178-02-F FLASH GOLD CONTACT, MATTE TIN TAIL	IM-1G18-XX-F FLASH GOLD CONTACT, MATTE TIN TAIL	WT-16-XX-T MATTE TIN ALL OVER
-LM	C-177-01-L LIGHT GOLD CONTACT, MATTE TIN TAIL	C-178-02-L LIGHT GOLD CONTACT, MATTE TIN TAIL	IM-1G18-XX-L LIGHT GOLD CONTACT, MATTE TIN TAIL	WT-16-XX-T MATTE TIN ALL OVER

F:\DWG\MISC\MKTG\QSS-XXX-XX-XX-D-RA-WT-XXX-MKT.SLDDRW

<p>PROPRIETARY NOTE THIS DOCUMENT CONTAINS INFORMATION CONFIDENTIAL AND PROPRIETARY TO SAMTEC, INC. AND SHALL NOT BE REPRODUCED OR TRANSFERRED TO OTHER DOCUMENTS OR DISCLOSED TO OTHERS OR USED FOR ANY PURPOSE OTHER THAN THAT WHICH IT WAS OBTAINED WITHOUT THE EXPRESSED WRITTEN CONSENT OF SAMTEC, INC.</p> <p>DO NOT SCALE DRAWING</p> <p>SHEET SCALE: 6:1</p>	 <p>520 PARK EAST BLVD, NEW ALBANY, IN 47150 PHONE: 812-944-6733 FAX: 812-948-5047 e-Mail: info@SAMTEC.com code: 55322</p>	
	<p>DESCRIPTION: .635mm DOUBLE ROW RIGHT ANGLE SOCKET STRIP</p> <p>DWG. NO. QSS-XXX-XX-XX-D-RA-WT-XXX</p>	
<p>BY: KEVIN B 01/22/02</p>		<p>SHEET 2 OF 5</p>

IN-PROCESS 1

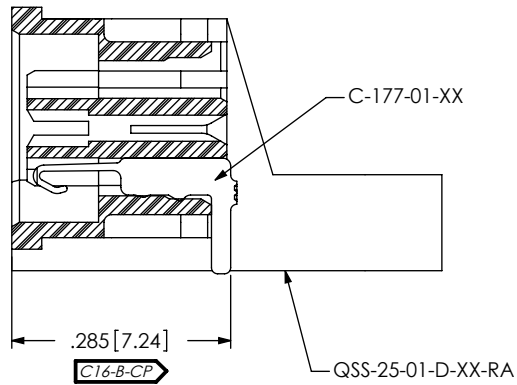

IN-PROCESS 2

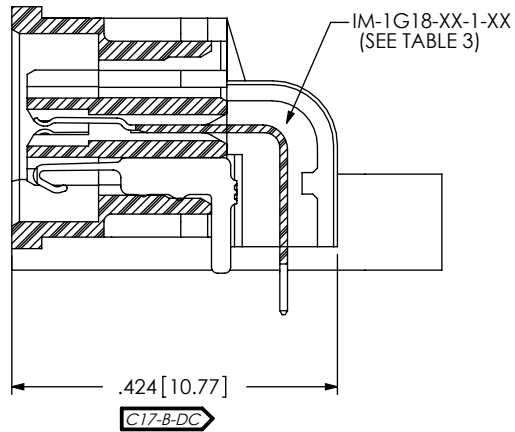

IN-PROCESS 3

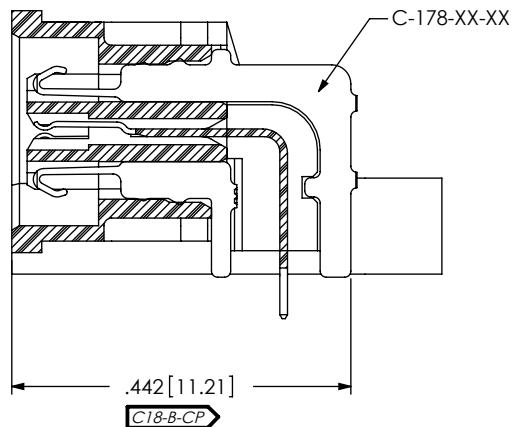
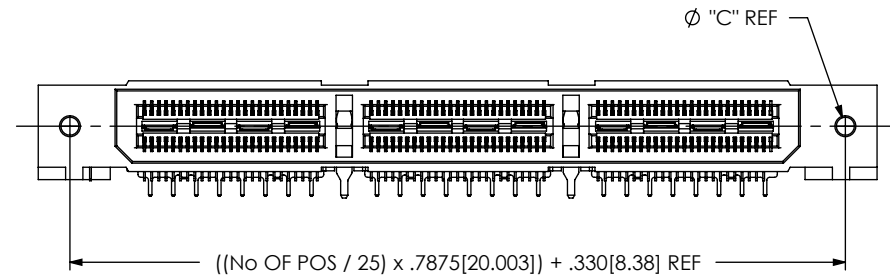
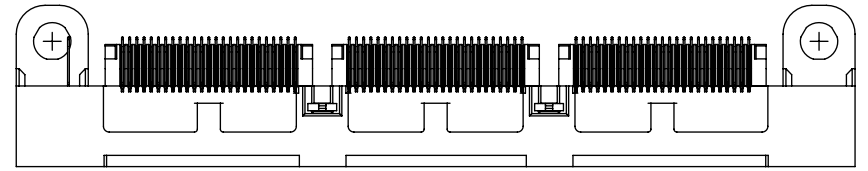

FIG. 2

QSS-075-01-X-D-RA-LS1 SHOWN
(SAME AS FIG. 1, EXCEPT AS SHOWN)



CRITICAL DIMENSION INSPECTION INSTRUCTION TABLE

ASSEMBLY OPERATION	START-UP INSPECTION INSPECT CODE A	IN-PROCESS INSPECTION INSPECT CODE B
FILL C-177-01-X	C1, C14, C15	C16
FILL IM-1G18-XX-1-XX	C1, C14, C15, C16	C17
FILL C-178-XX-X	C1, C14, C15, C16, C17	C18
FILL WT-16-XX-T	C1, C14, C15, C16, C17, C18	C6

F:\DWG\MISC\MKTG\QSS-XXX-XX-XX-D-RA-WT-XXX-MKT.SLDDRW

PROPRIETARY NOTE

THIS DOCUMENT CONTAINS INFORMATION CONFIDENTIAL AND PROPRIETARY TO SAMTEC, INC. AND SHALL NOT BE REPRODUCED OR TRANSFERRED TO OTHER DOCUMENTS OR DISCLOSED TO OTHERS OR USED FOR ANY PURPOSE OTHER THAN THAT WHICH IT WAS OBTAINED WITHOUT THE EXPRESSED WRITTEN CONSENT OF SAMTEC, INC.

DO NOT SCALE DRAWING

SHEET SCALE: 1.5:1



520 PARK EAST BLVD, NEW ALBANY, IN 47150
PHONE: 812-944-6733 FAX: 812-948-5047
e-Mail: info@SAMTEC.com code: 55322

DESCRIPTION:
.635mm DOUBLE ROW RIGHT ANGLE SOCKET STRIP

DWG. NO.
QSS-XXX-XX-XX-D-RA-WT-XXX

BY: KEVIN B 01/22/02 SHEET 3 OF 5

FIG. 3
 QSS-075-01-X-D-RA-WT-SP SHOWN
 (SAME AS FIG. 1, EXCEPT AS SHOWN)

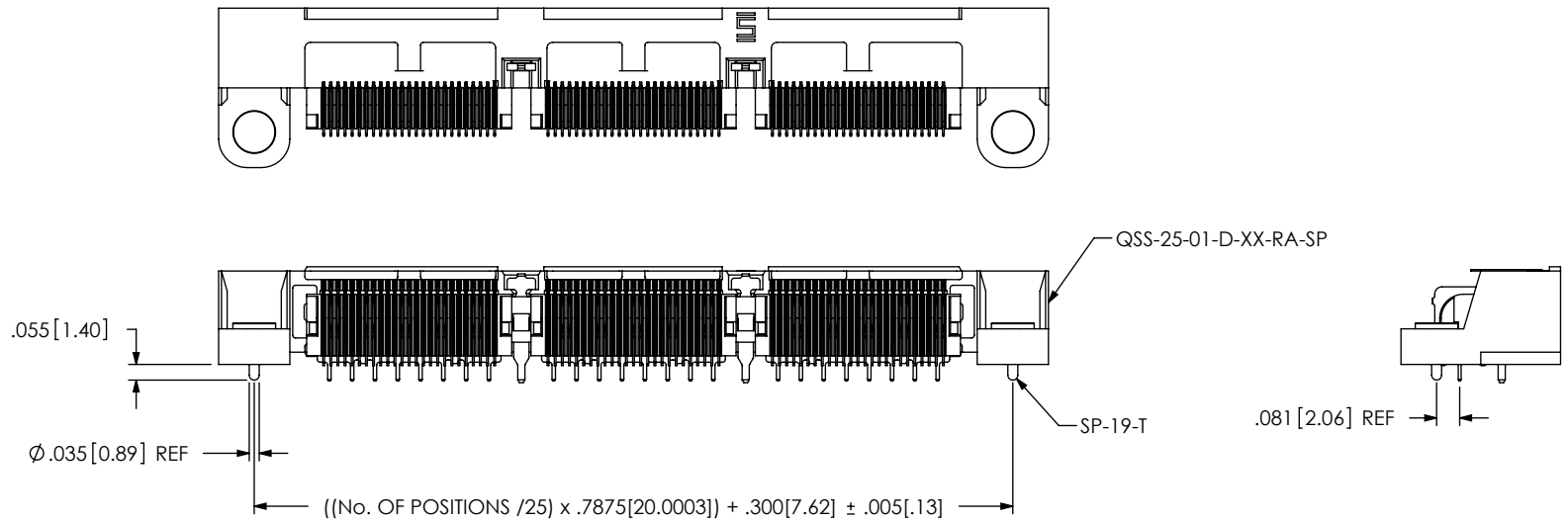

FIG. 4
 QSS-075-01-X-D-RA-WT-K SHOWN
 (SAME AS FIG. 1, EXCEPT AS SHOWN)

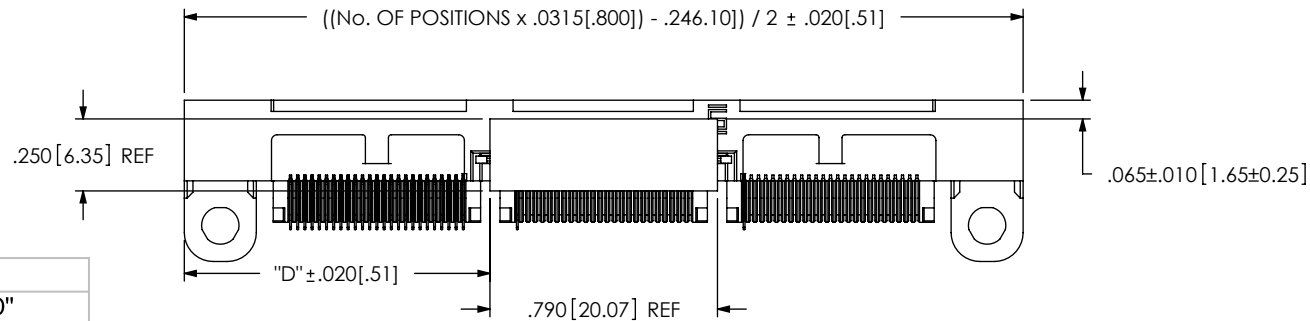

TABLE 5

NO OF POS	"D"
25	0.274 [6.95]
50	0.668 [16.96]
75	1.061 [26.95]
100	1.455 [36.96]

PROPRIETARY NOTE
 THIS DOCUMENT CONTAINS INFORMATION
 CONFIDENTIAL AND PROPRIETARY TO
 SAMTEC, INC. AND SHALL NOT BE REPRODUCED
 OR TRANSFERRED TO OTHER DOCUMENTS OR
 DISCLOSED TO OTHERS OR USED FOR ANY
 PURPOSE OTHER THAN THAT WHICH IT WAS
 OBTAINED WITHOUT THE EXPRESSED WRITTEN
 CONSENT OF SAMTEC, INC.

DO NOT SCALE DRAWING

SHEET SCALE: 1.5:1

samtec

520 PARK EAST BLVD, NEW ALBANY, IN 47150
 PHONE: 812-944-6733 FAX: 812-948-5047
 e-Mail: info@SAMTEC.com code: 55322

DESCRIPTION:
 .635mm DOUBLE ROW RIGHT ANGLE SOCKET STRIP

DWG. NO.
 QSS-XXX-XX-XX-D-RA-WT-XXX

BY: KEVIN B 01/22/02 SHEET 4 OF 5

FIG. 5
 QSS-075-01-X-D-RA-WT-MTI SHOWN
 (SAME AS FIG. 1, EXCEPT AS SHOWN)

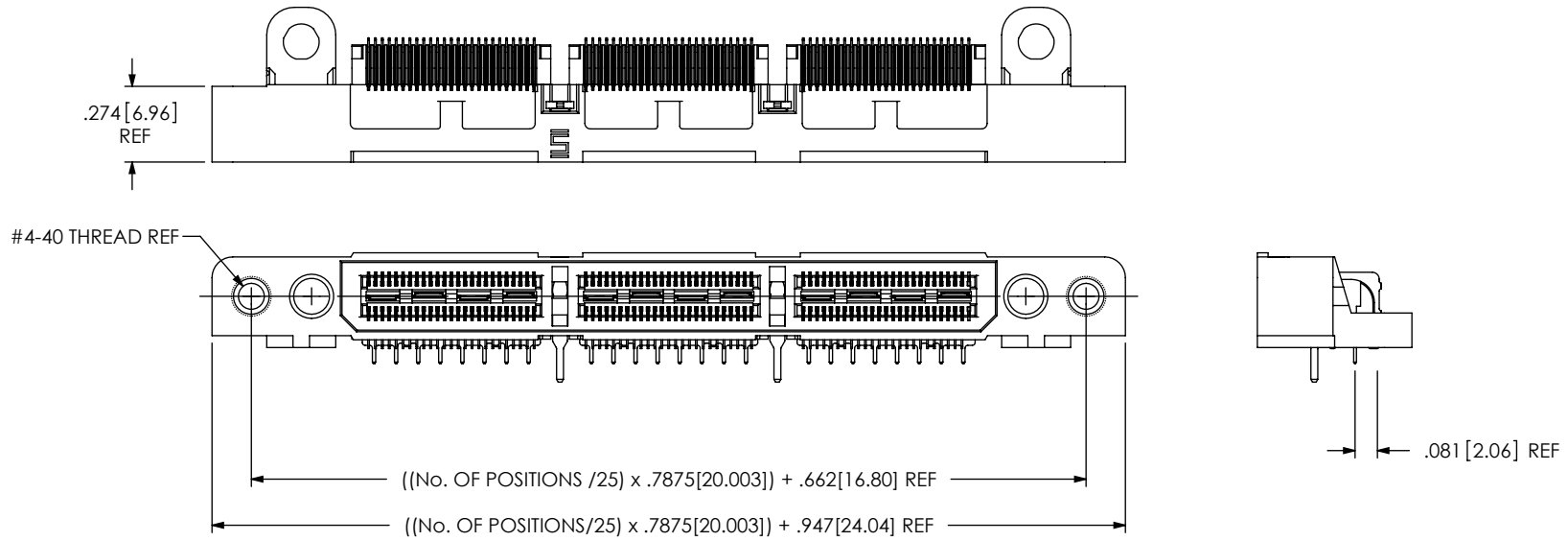

PROPRIETARY NOTE
 THIS DOCUMENT CONTAINS INFORMATION CONFIDENTIAL AND PROPRIETARY TO SAMTEC, INC. AND SHALL NOT BE REPRODUCED OR TRANSFERRED TO OTHER DOCUMENTS OR DISCLOSED TO OTHERS OR USED FOR ANY PURPOSE OTHER THAN THAT WHICH IT WAS OBTAINED WITHOUT THE EXPRESSED WRITTEN CONSENT OF SAMTEC, INC.

DO NOT SCALE DRAWING

SHEET SCALE: 1.5:1



520 PARK EAST BLVD, NEW ALBANY, IN 47150
 PHONE: 812-944-6733 FAX: 812-948-5047
 e-Mail: info@SAMTEC.com code: 55322

DESCRIPTION:
 .635mm DOUBLE ROW RIGHT ANGLE SOCKET STRIP

DWG. NO. QSS-XXX-XX-XX-D-RA-WT-XXX

BY: KEVIN B 01/22/02 SHEET 5 OF 5