

LOC	DIST	REVISIONS			
P	LR	DESCRIPTION	DATE	DWN	APPD
AJ	16	A	REVISED PER EC OS14-0150-05	30AUG05	BM JL

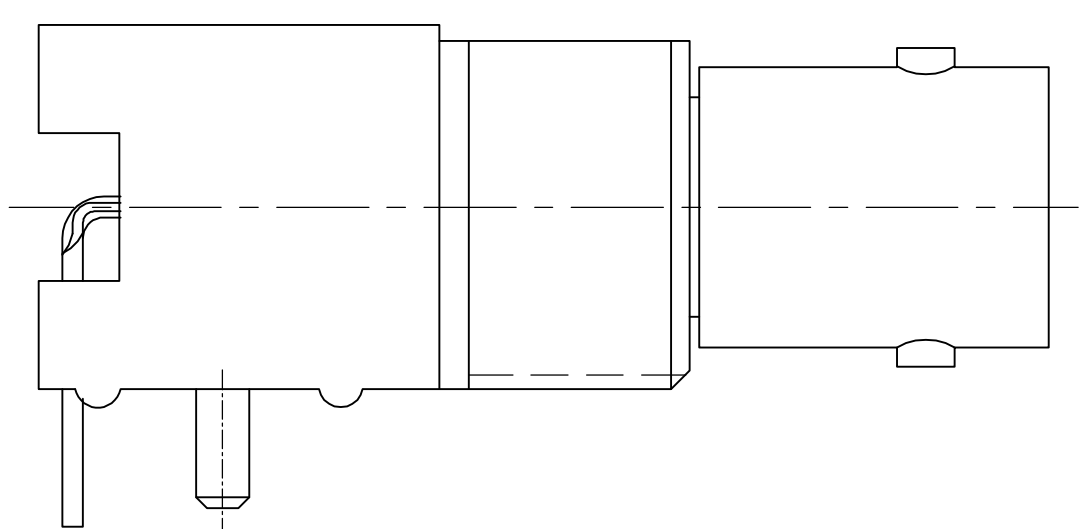

VIEW C
(SAME AS VIEW A EXCEPT AS SHOWN)

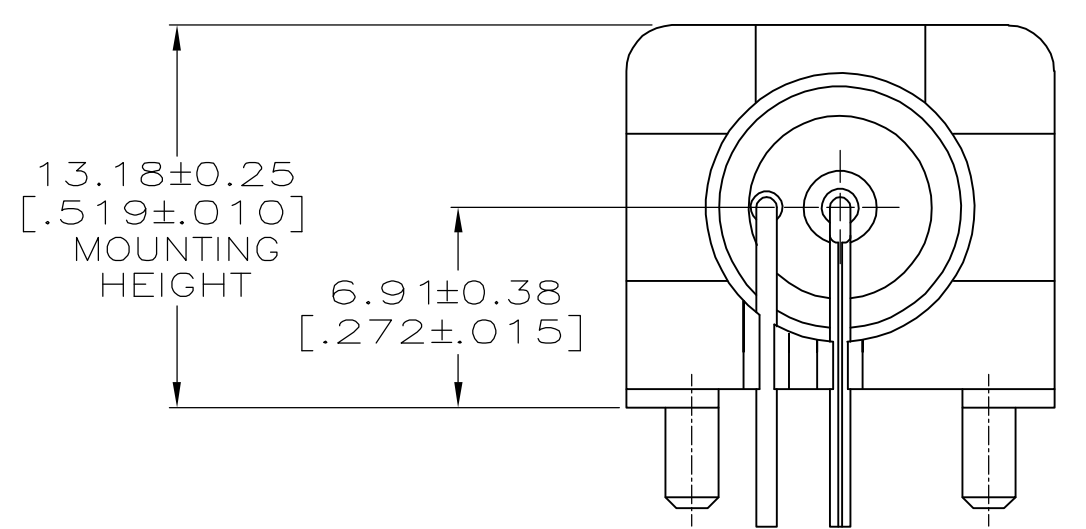
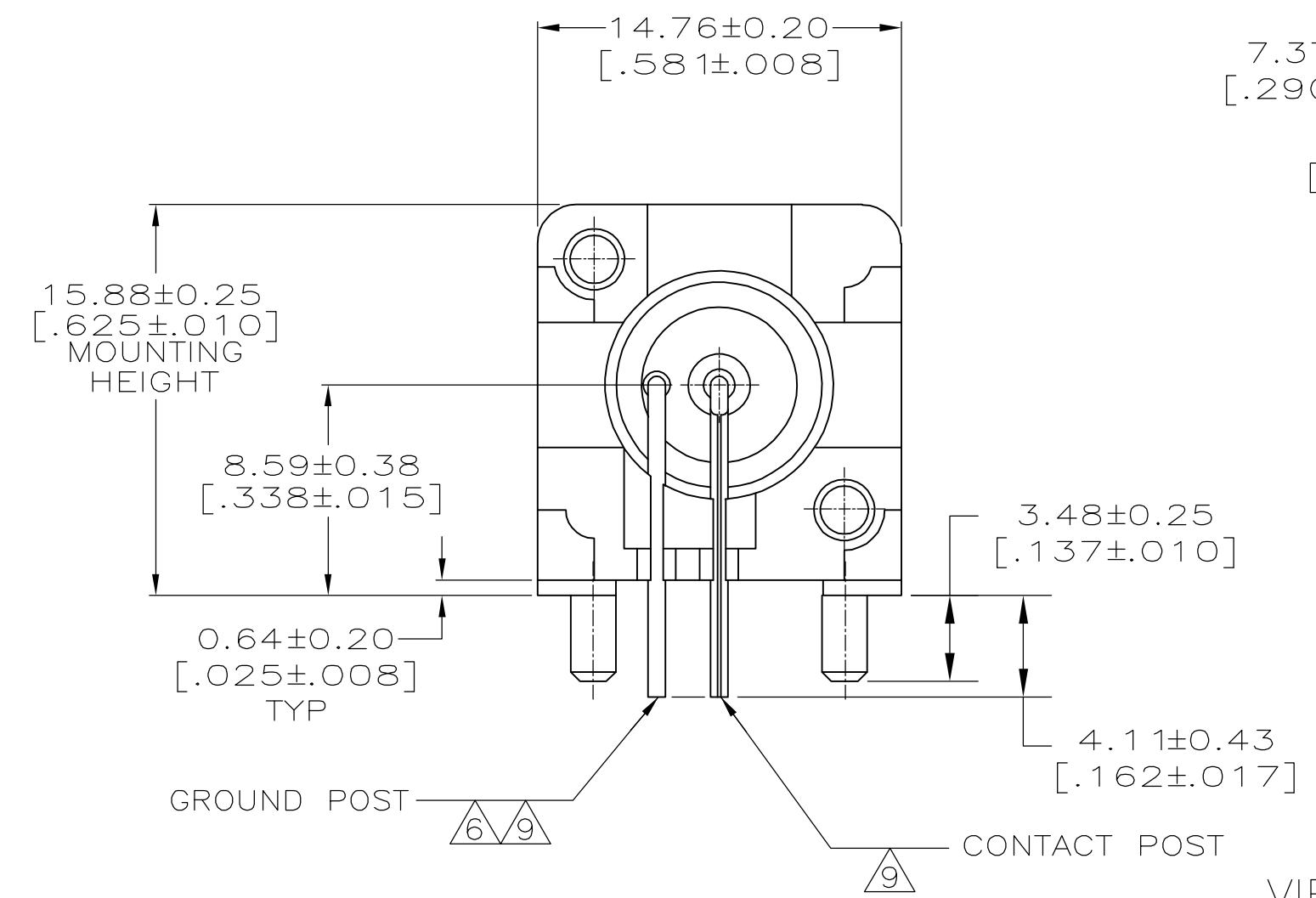

VIEW A

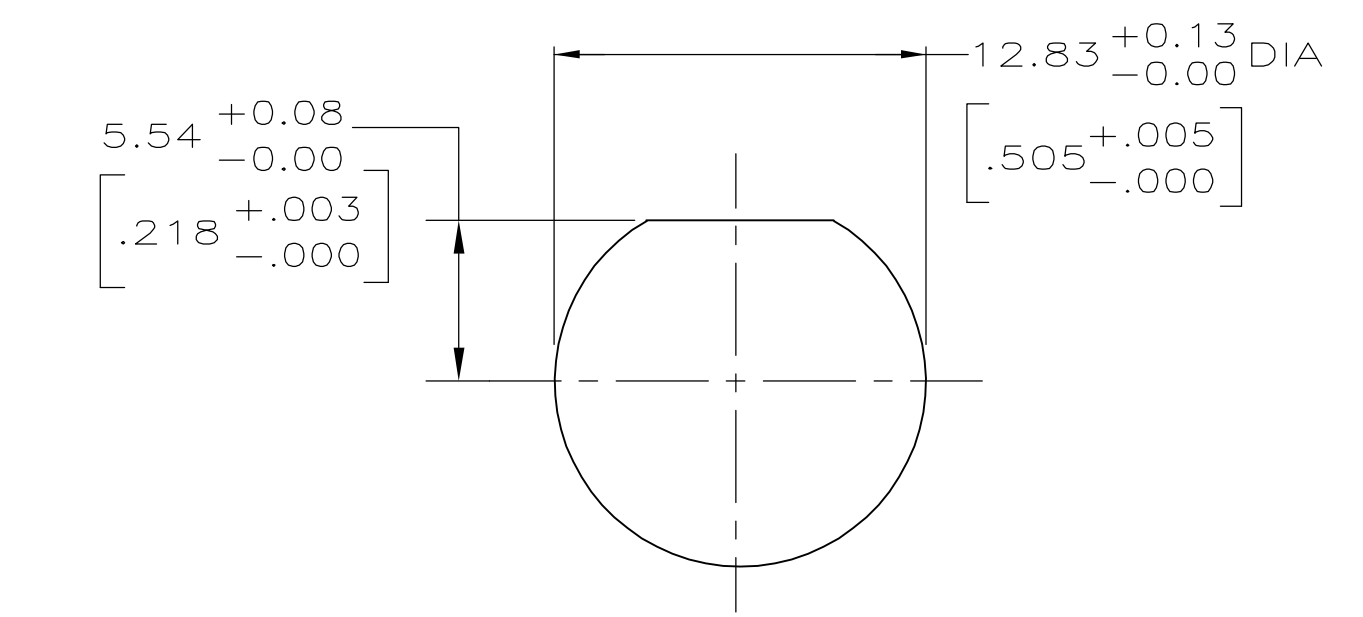
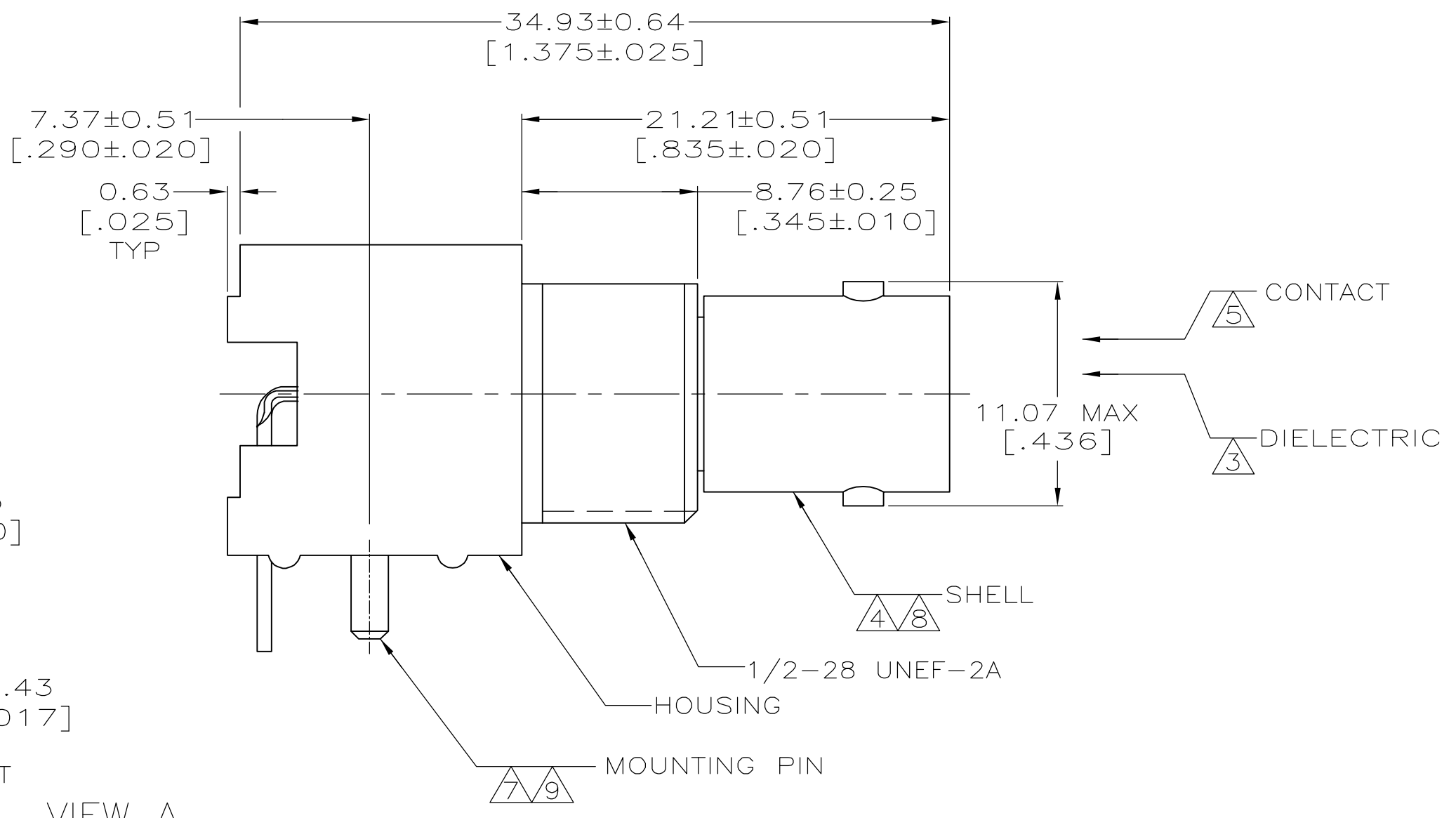

RECOMMENDED PANEL CUTOUT

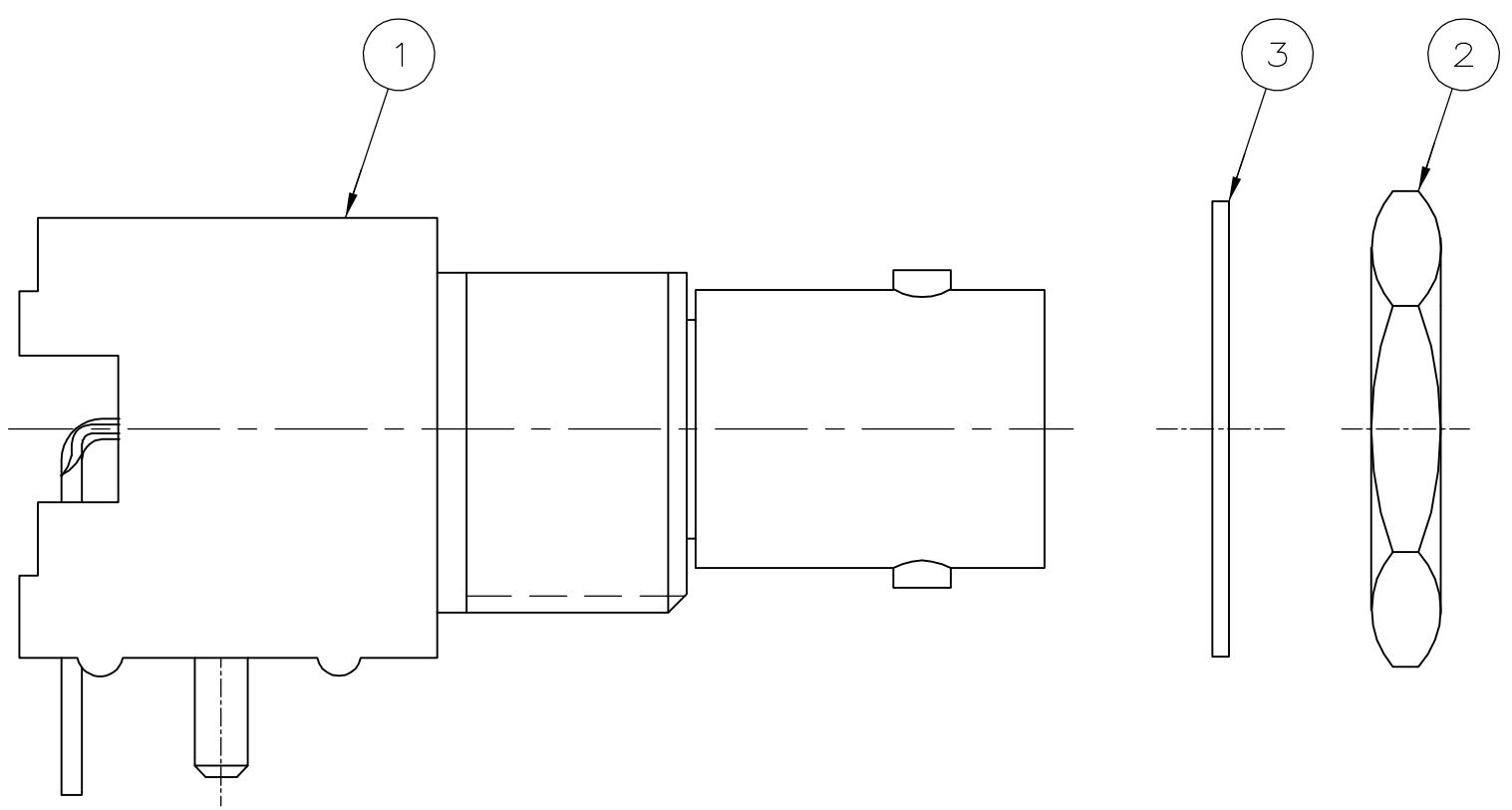

VIEW B

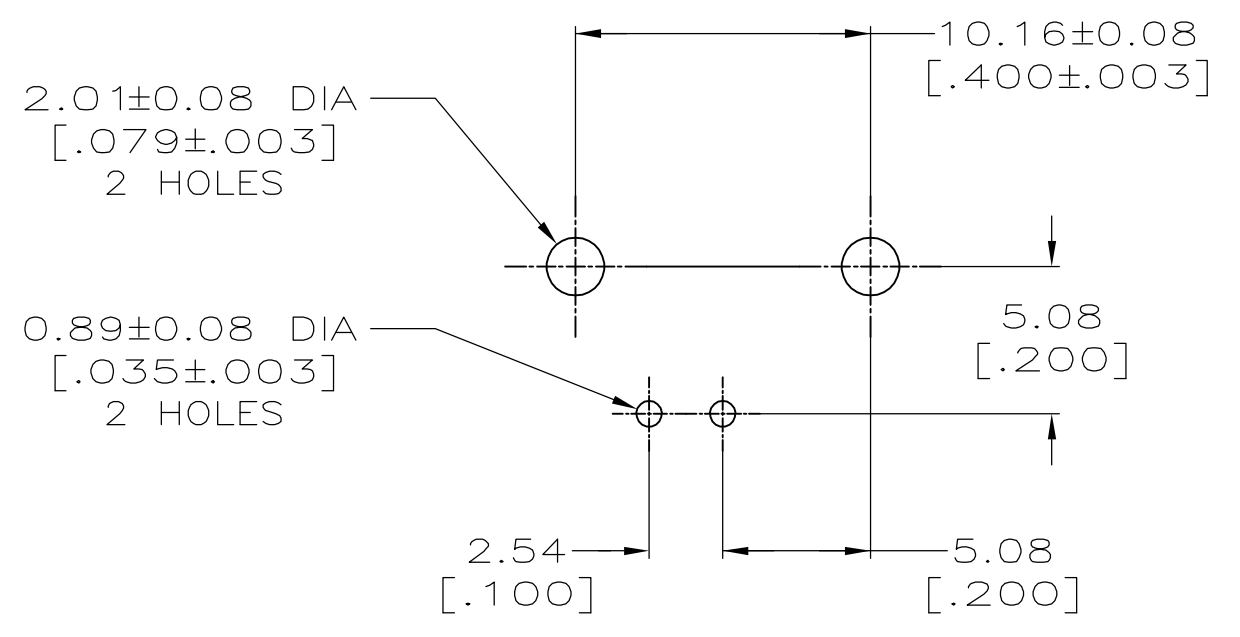

PCB CONFIGURATION

CONTACT FINISH	HOUSING MATERIAL	VIEW	LOCKWASHER	JAM NUT QTY=1	ASSEMBLY QTY=1	PART NUMBER
-	-	B	1-329632-2	1-329631-2	5227161-9	1-5227161-7
-	-	B	1-329632-2	1-329631-2	5227161-6	1-5227161-6
△	△	C	-	-	-	1-5227161-5
△	△	C	-	-	-	5227161-9
△	△	C	-	-	-	5227161-7
△	△	A	-	-	-	5227161-6
△	△	A	-	-	-	5227161-3
△	△	A	-	-	-	5227161-2
△	△	A	-	-	-	5227161-1

THIS DRAWING IS A CONTROLLED DOCUMENT.

DIMENSIONS: mm[INCHES]	TOLERANCES UNLESS OTHERWISE SPECIFIED:	0 PLC ± -	1 PLC ± -	2 PLC ± 0.05 [0.02]	3 PLC ± -	4 PLC ± -	ANGLES ± -	FINISH
MATERIAL		APVD		PRODUCT SPEC		APPLICATION SPEC		WEIGHT
△△△△△△△△		L VARELA - DOCK5		108-12078		SIZE CAE CODE DRAWING NO		RESTRICTED TO
CUSTOMER DRAWING		L HAVENER		S BURKHOLDER		A1 00779 C=5227161		SCALE 4:1 SHEET 1 OF 1 REV A

tyco Electronics Corporation Harrisburg, Pa 17105-3608
 JACK, RIGHT ANGLE, 50 OHM, PCB, BNC