

THIS DRAWING IS UNPUBLISHED. RELEASED FOR PUBLICATION 14MAR06, 2006.  
 © COPYRIGHT 2006 BY TYCO ELECTRONICS CORPORATION. ALL RIGHTS RESERVED.

LOC	DIST	REVISIONS					
E	B	P	LTR	DESCRIPTION	DATE	DWN	APVD
		B		ECR-07-004803	26FEB07	AM	FWK

- NOTES:**
- ELECTRICAL DATA: CONTACT RESISTANCE: 10 mOhm MAX  
 INSULATION RESISTANCE: 100 MOhm MIN at 500VDC  
 CURRENT RATING: 5 AMPS (FOR 3, 4 AND 5 POSITIONS) AND 2 AMPS (FOR 8 POSITION ONLY)  
 BREAKDOWN VOLTAGE: 500 VAC MIN PER MINUTE
  - ENVIRONMENTAL: OPERATING TEMPERATURE: -25°C TO +90°C  
 SEALING REQUIREMENTS: IP67
  - PACKAGING: 107-3334
  - SEAL FOR CABLE OD:  $\phi$ 4.5mm -  $\phi$ 6.5mm
  - FOR TECHNICAL DATA REFER TO YOUR LOCAL TYCO ELECTRONICS SALES OFFICE.
  - ALL DIMENSIONS ARE FOR NOMINAL REFERENCE ONLY UNLESS OTHERWISE STATED.

ITEM	DESCRIPTION	MATERIAL	FINISH/COLOUR	QUANTITY / ITEM		
				-1	-2	-3
1	CONNECTOR HOUSING	GF NYLON	BLACK	1	1	1
2	GASKET	SILICONE	BLACK	1	1	1
3	CONNECTOR BODY	GF NYLON	BLACK	1	1	1
4	SEALING NUT	GF NYLON	BLACK	1	1	1
5	SEAL	EPDM	BLACK	1	1	1
6	PIN CONTACT	BRASS	0.15 $\mu$ m GOLD OVER NICKEL	3	4	5
7	SCREW NUT	ZINC DIE CAST	2.5 $\mu$ m NICKEL PLATED	1	1	1

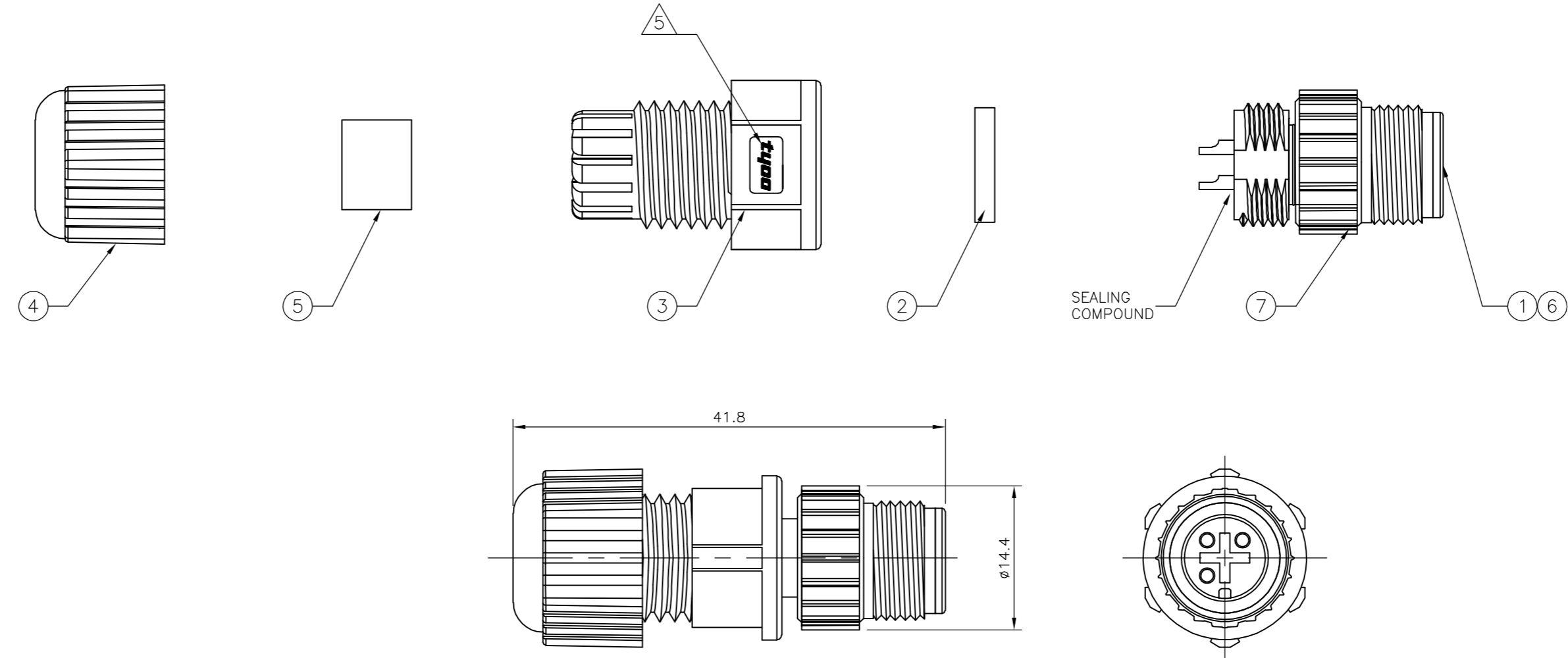

1838275-1  
PIN ASSIGNMENTS  
FRONT VIEW

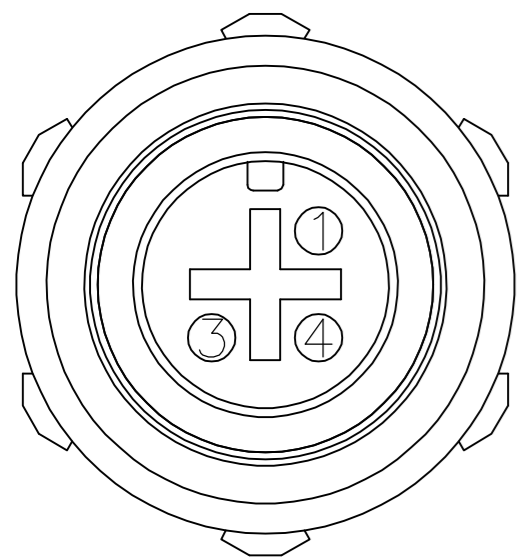

1838275-2  
PIN ASSIGNMENTS  
FRONT VIEW

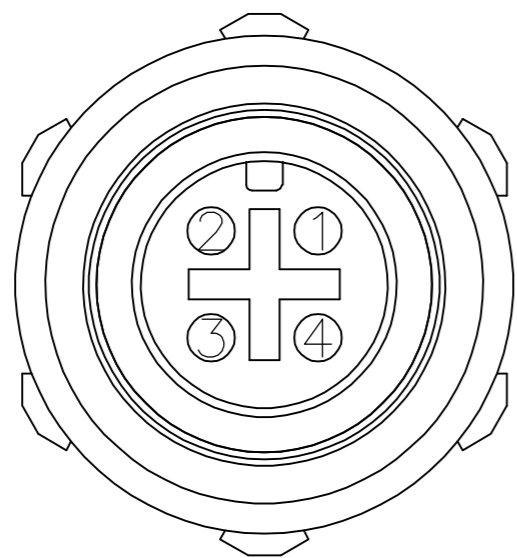

1838275-3  
PIN ASSIGNMENTS  
FRONT VIEW

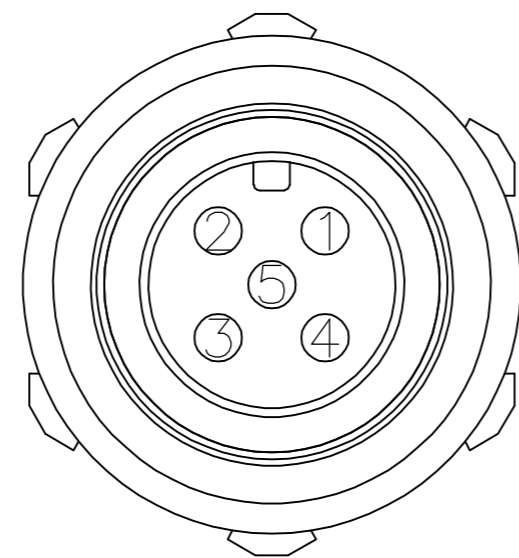

1838275-4  
PIN ASSIGNMENTS  
FRONT VIEW

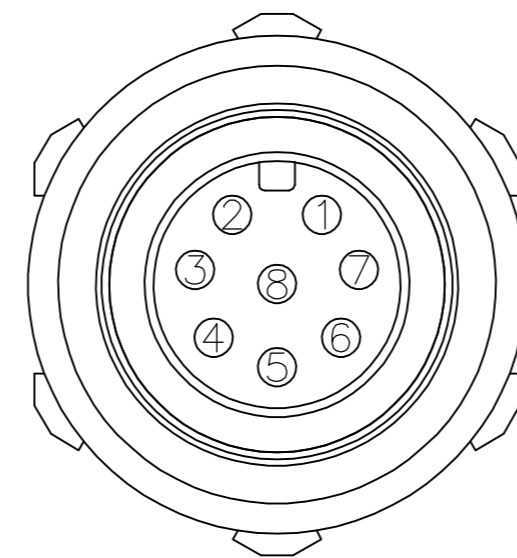

DESCRIPTION	NO. OF POS	PART NUMBER
M12 FIELD SERVICEABLE CONNECTOR, MALE PIN, SOLDER TYPE	8	1838275-3
M12 FIELD SERVICEABLE CONNECTOR, MALE PIN, SOLDER TYPE	5	1838275-3
M12 FIELD SERVICEABLE CONNECTOR, MALE PIN, SOLDER TYPE	4	1838275-2
M12 FIELD SERVICEABLE CONNECTOR, MALE PIN, SOLDER TYPE	3	1838275-1

THIS DRAWING IS A CONTROLLED DOCUMENT.

DWN	A. Morey	14MAR06	Tyco Electronics Corporation Bideford, UK, EX39 4HE	
CHK	F. Wheeler-King	12APR06		
APVD	F. Wheeler-King	12APR06		
PRODUCT SPEC				
APPLICATION SPEC			NAME	
WEIGHT			M12 FIELD SERVICEABLE CONNECTOR, MALE PIN, SOLDER TYPE	
CUSTOMER DRAWING			SIZE	A2
			CAGE CODE	00779
			DRAWING NO	C=1838275
			RESTRICTED TO	
			SCALE	NTS
			SHEET	1 OF 1
			REV	B