

SUPPLY VOLTAGE MONITOR

ISSUE 2 – JANUARY 2003

ZSM330

DEVICE DESCRIPTION

The ZSM330 is a three terminal under voltage monitor circuit for use in microprocessor systems. The threshold voltage of the device has been set to 3.1 volts making it ideal for 3.3 volt circuits.

Included in the device is a precise voltage reference and a comparator with built in hysteresis to prevent erratic operation. The ZSM330 features an open collector output capable of sinking at least 10mA which only requires a single external resistor to interface to following circuits.

Operation of the device is guaranteed from one volt upwards, from this level to the device threshold voltage the output is held low providing a power on reset function. Should the supply voltage, once established, at any time drop below the threshold level then the output again will pull low.

The device is available in a TO92 package for through hole applications as well as SOT223 for surface mount requirements.

FEATURES

- SOT223 and TO92 packages
- Power on reset generator
- Automatic reset generation
- Low standby current
- Guaranteed operation from 1 volt
- Wide supply voltage range
- Internal clamp diode to discharge delay capacitor
- 3.1 volt threshold for 3.3 volt logic
- 20mV hysteresis prevents erratic operation

APPLICATIONS

- Microprocessor systems
- Computers
- Computer peripherals
- Instrumentation
- Automotive
- Battery powered equipment

SCHEMATIC DIAGRAM

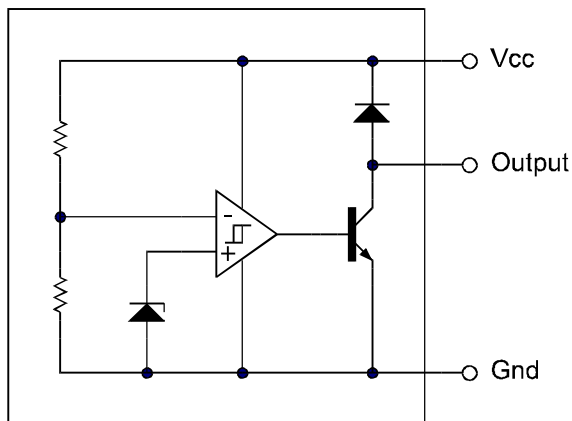

ZSM330

ABSOLUTE MAXIMUM RATING

Input Supply Voltage	-1 to 10V	Power Dissipation	
Offstate Output Voltage	10V	TO92	780mW
Onstate Output		SOT223	2W(Note 2)
Sink Current(Note 1)	Internally limited		
Clamp Diode			
Forward Current(Note 1)	100mA		
Operating Junction Temperature	150°C		
Operating Temperature	-40 to 85°C		
Storage Temperature	-55 to 150°C		

TEST CONDITIONS

($T_{amb}=25^{\circ}\text{C}$ for typical values, $T_{amb}=-40$ to 85°C for min/max values (Note3))

COMPARATOR

PARAMETER	SYMBOL	MIN	TYP.	MAX.	UNITS
Threshold Voltage High state output (V_{cc} increasing)	V_{IH}	3.01	3.09	3.15	V
Threshold Voltage Low state output (V_{cc} decreasing)	V_{IL}	3.01	3.07	3.15	V
Hysteresis	V_H	0.01	0.02	0.05	V

OUTPUT

Output sink saturation: ($V_{cc}=2.7\text{V}$, $I_{sink}=8.0\text{mA}$) ($V_{cc}=2.7\text{V}$, $I_{sink}=2.0\text{mA}$) ($V_{cc}=1.0\text{V}$, $I_{sink}=0.1\text{mA}$)	V_{OL}		0.46 0.15	1.0 0.4 0.25	V V V
Onstate output sink current (V_{cc} , Output=2.7V)	I_{sink}	10	27	60	mA
Offstate output leakage current (V_{cc} , Output=3.3V)	I_{oh}		0.02	0.5	μA
Clamp diode forward voltage ($I_f=10\text{mA}$)	V_f	0.6	1.2	1.5	V
Propagation delay (V_{in} 3.3V to 2.7V, $R_l=10\text{k}$, $T_{amb}=25^{\circ}\text{C}$)	T_d		2.2		μs

TOTAL DEVICE

Operating input voltage range	V_{cc}	1.0 to 6.5			V
Quiescent input current ($V_{cc}=3.3\text{V}$)	I_q		120	180	μA

Note:

1. Maximum package power dissipation must be observed
2. Maximum power dissipation for the SOT223 package is calculated assuming that the device is mounted on a PCB measuring 2 inches square.
3. Low duty cycle pulse techniques are used during test to maintain junction temperatures as close to ambient as possible

ZSM330

TYPICAL CHARACTERISTICS

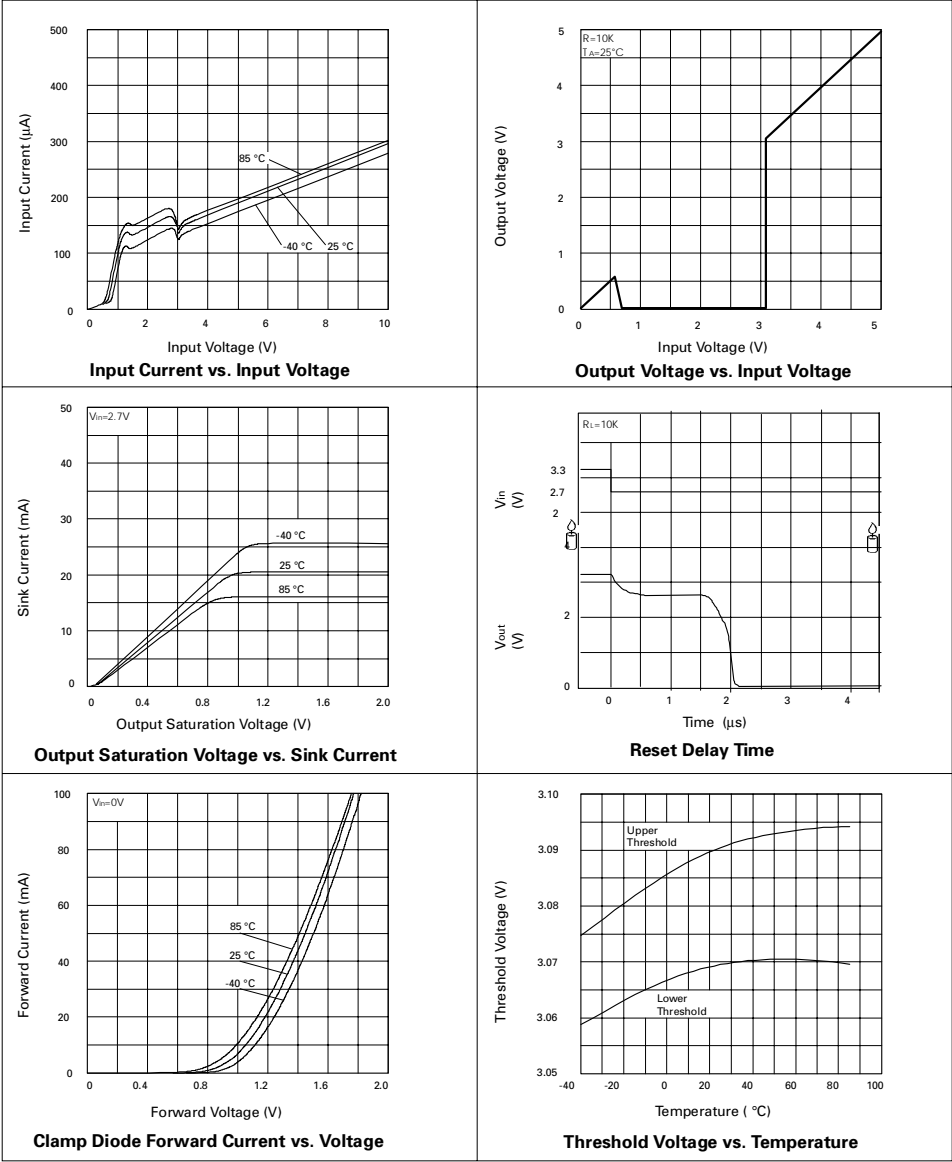

ZSM330

TIMING DIAGRAM

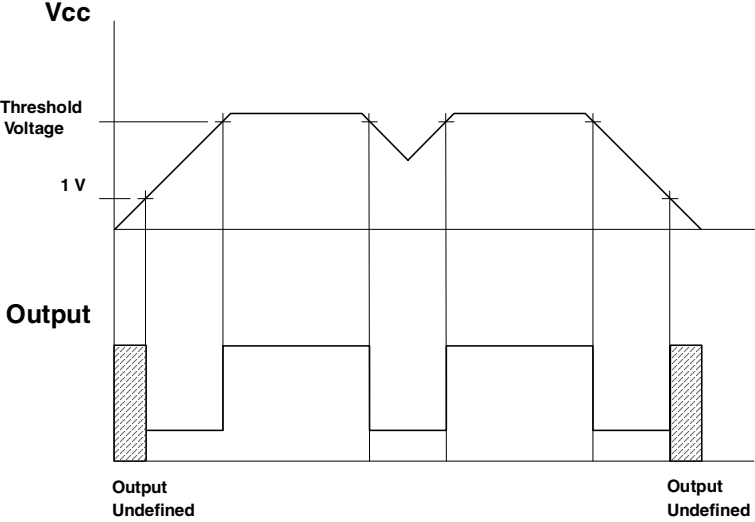

APPLICATION CIRCUIT

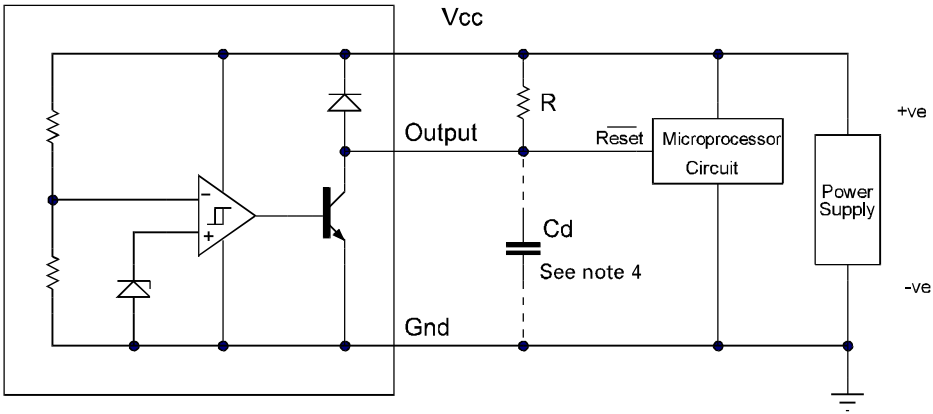

Note 4: A time delayed reset can be accomplished with the additional Cd.

$$T_{DY} = RCd \ln \left(\frac{1}{1 - \frac{V_{TH}(mpu)}{V_{in}}} \right)$$

T_{DY} =Time (Seconds)
 V_{TH} =Microprocessor Reset Threshold
 V_{in} =Power Supply Voltage

ZSM330

CONNECTION DIAGRAMS

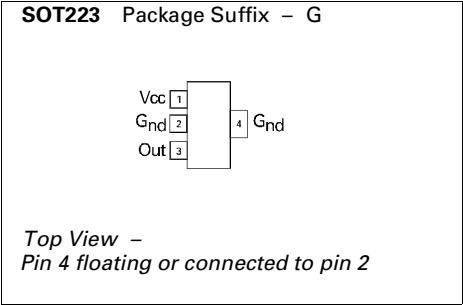
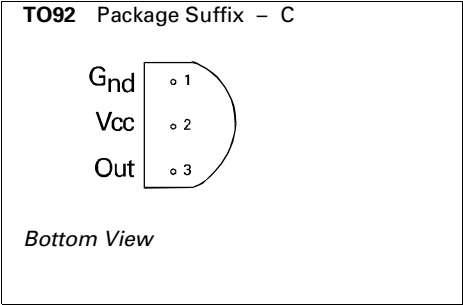

ORDERING INFORMATION

Part Number	Package	Part Mark
ZSM330G	SOT223	ZSM330
ZSM330C	TO92	ZSM330

PRODUCT AND INFORMATION DISCLAIMER

This publication is issued to provide outline information only which (unless agreed by the Company in writing) may not be used, applied or reproduced for any purposes or form part of any order or contract or be regarded as representation relating to the products or services concerned. The company reserves the right to alter without notice the specification, design, price or conditions of supply of any product or service.

Some changes to earlier published data may have been made, data presented in this hand book supersedes all previous specifications. The information contained in this publication has been carefully checked and is considered to be accurate, but no responsibility is assumed for any inaccuracies.

Zetex makes no warranty, representation or guarantee regarding the suitability of the products and circuits in this publication for any given purpose; nor does Zetex assume any liability arising from the use or application of any of these products or circuits and specifically disclaims any and all consequential and incidental damages.

Zetex products are specifically not authorised for use as critical components in life support devices or systems without the express written approval of the Managing Director of Zetex plc. As used herein -

a. Life support devices or systems are devices or systems which

(1) are intended to implant into the body, or

(2) support or sustain life and whose failure to perform when properly used in accordance with instructions for use provided in the labelling can be reasonably expected to result in significant injury to the user.

b. A critical component is any component in a life support device or system whose failure to perform can be reasonably expected to cause the failure of the life support device or to affect its safety or effectiveness.

E. & O. E.

"all rights reserved"

© Zetex plc 2002

Europe		Americas	Asia Pacific
Zetex plc Fields New Road Chadderton Oldham, OL9 8NP United Kingdom Telephone (44) 161 622 4422 Fax: (44) 161 622 4420 uk.sales@zetex.com	Zetex GmbH Streitfeldstraße 19 D-81673 München Germany Telefon: (49) 89 45 49 49 0 Fax: (49) 89 45 49 49 49 europe.sales@zetex.com	Zetex Inc 700 Veterans Memorial Hwy Hauppauge, NY11788 USA Telephone: (631) 360 2222 Fax: (631) 360 8222 usa.sales@zetex.com	Zetex (Asia) Ltd 3701-04 Metroplaza, Tower 1 Hing Fong Road Kwai Fong Hong Kong Telephone: (852) 26100 611 Fax: (852) 24250 494 asia.sales@zetex.com

These offices are supported by agents and distributors in major countries world-wide.

This publication is issued to provide outline information only which (unless agreed by the Company in writing) may not be used, applied or reproduced for any purpose or form part of any order or contract or be regarded as a representation relating to the products or services concerned. The Company reserves the right to alter without notice the specification, design, price or conditions of supply of any product or service.

For the latest product information, log on to www.zetex.com

