

Top View of Assembly

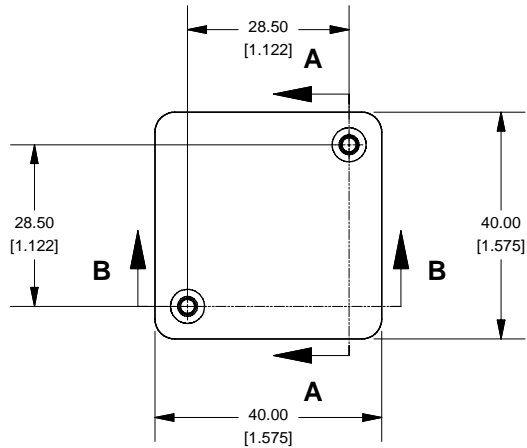

SECTION A-A End View of Assembly

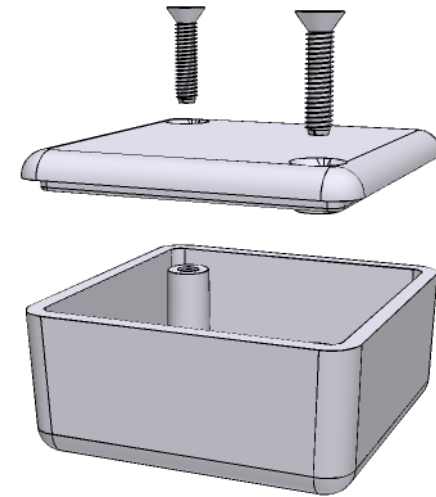
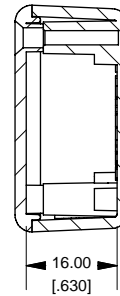

Top View Looking Inside Box

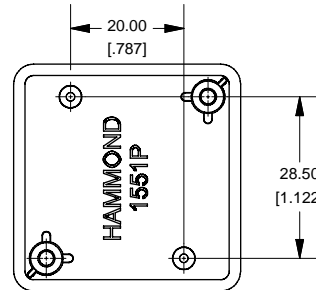

SECTION B-B Side View of Assembly

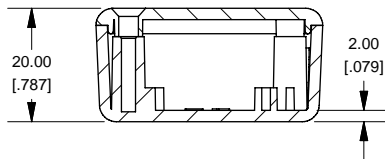

SECTION C-C Boss Heights

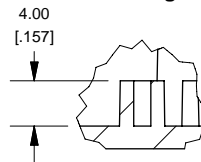

Lid

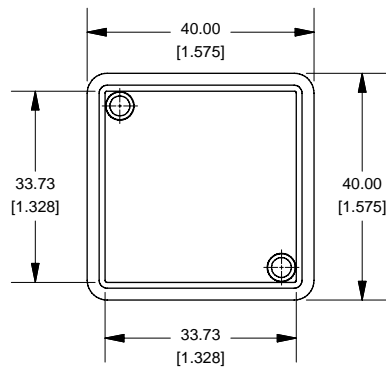

Maximum P.C. Board Size

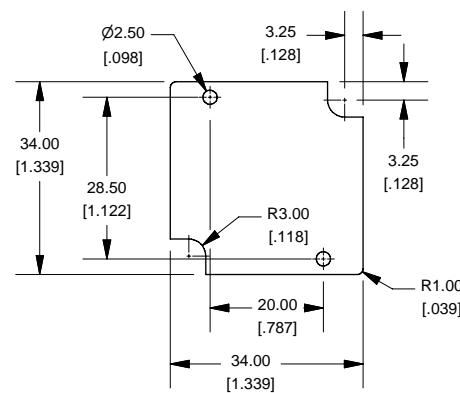

NOTE

Purchased assembly includes lid and box made from GP ABS material and cover screws.

1551P

1551P Flange Enclosure

Black Enclosure - RAL 7001 - UL94 - HB	1551PHBK
Gray Enclosure - RAL 7035 - UL94 - HB	1551PGY
Translucent Blue - UL94 - HB	1551PTBU

ACCESSORIES

Black Enclosure Cover Screws (Pkg 100) [#4 X 1/2" Self Tapping]	1591TS100BK
Grey Enclosure Cover Screws (Pkg 100) [#4 X 1/2" Self Tapping]	1591TS100
P.C. Board Screws (Pkg 100) [32 x 3/16" Self Tapping]	1551ATS100

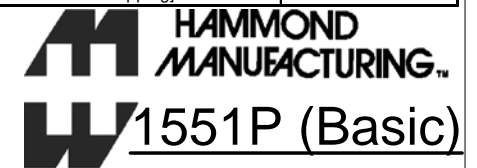

www.hammondmfg.com