

### Top View of Assembly

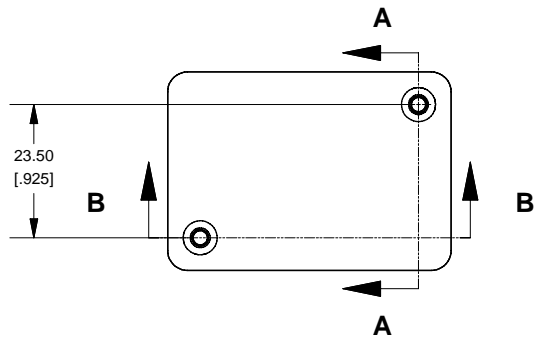

### SECTION A-A End View of Assembly

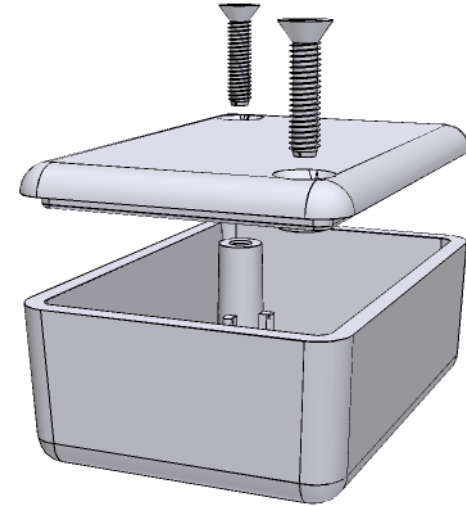
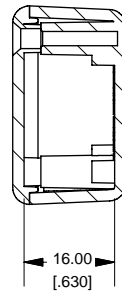

### Top View Looking Inside Box

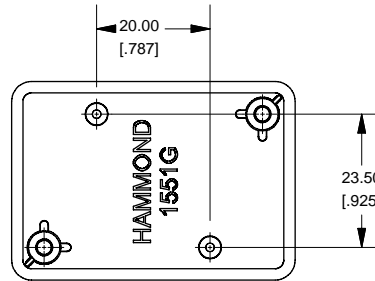

### SECTION B-B Side View of Assembly

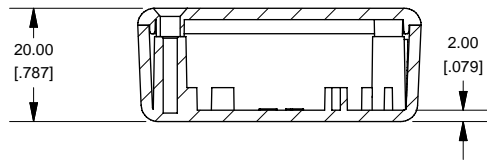

### SECTION C-C Boss Heights

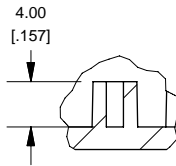

### Lid

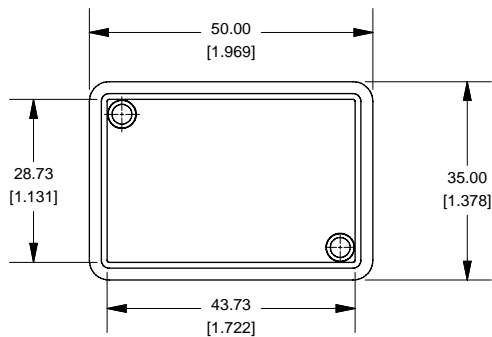

### Maximum P.C. Board Size

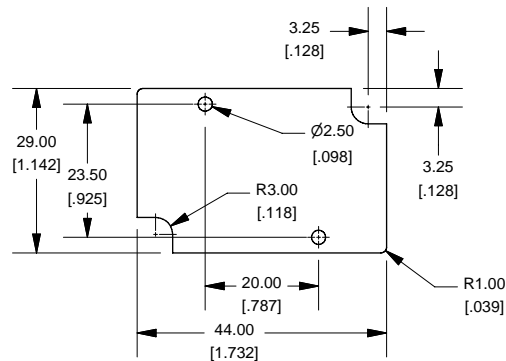

### NOTE

Purchased assembly includes lid and box made from GP ABS material and cover screws.

1551G	
1551G Flange Enclosure	
Black Enclosure - RAL 7001 - UL94 - HB	1551GHBK
Gray Enclosure - RAL 7035 - UL94 - HB	1551GGY
Translucent Blue - UL94 - HB	1551GTBU
ACCESSORIES	
Black Enclosure Cover Screws (Pkg 100) [#4 X 1/2" Self Tapping]	1591TS100BK
Grey Enclosure Cover Screws (Pkg 100) [#4 X 1/2" Self Tapping]	1591TS100
P.C. Board Screws (Pkg 100) [32 x 3/16" Self Tapping]	1551ATS100



[www.hammondmfg.com](http://www.hammondmfg.com)