



8STA shell size 02



Features & Benefits

- The smallest circular connector with removable contacts #26
- Ultra compact design & very lightweight connector
- Rugged aluminium body to ensure long service life in the harshest environment
- Positive locking mechanism with locked colour indicators
- 7 colour-coded keyway orientations
- Boot termination feature
- PCB option available
- Conductive black zinc plating

Technical characteristics

Mechanical

• Shell	Aluminium alloy
• Shell plating	Conductive black zinc (standard)
• Insulator	Thermoplastic
• Grommet & seal	Liquid silicone rubber
• Contact	Copper alloy
• Contact plating	Gold
• Endurance	500 matings/unmatings
• Shock	300 g for 3 ms and EIA-364-27
• Vibration	147 m/s ² , 10 to 2000 Hz
• Contact retention	35 N (size 26) 45 N (size 22D)

Electrical

• Test voltage	400 Vrms (size 26) 1000 Vrms (size 22D)
• Contact resistance	< 16 mΩ (size 26) < 14.6 mΩ (size 22D)
• Insulation resistance	> 5000 mΩ (at 400 Vdc / size 26) > 5000 mΩ (at 500 Vdc / size 22D)
• Contact rating	3 A (size 26) 5 A (size 22D)

Climatic

• Temperature range	-55°C to +175°C
• Sealing mated connectors	IP67 (1 metre for 30 min. minimum)
• Salt spray	48 hours



8STA shell size 02

How to order

Basic series	8STA 0 - 02 05 P N -
Shell style	0: Oval flange receptacle 1: In-line receptacle 2: Oval flange receptacle with PCB contacts 6: Plug
Plating	- : Standard version F: Nickel version
Shell size	02
Contact layouts	See page 6-8
Type of contacts	P: Pin contacts S: Socket contacts
Orientations	N: Red / A: Yellow / B: Blue / C: Orange / D: Green / E: Grey / U: Universal
Specification	- : Standard version 499: Integrated nut on the flange - M2 insert (only for shell style 0 & 2) - for more details, please see page 45-48 528: Integrated nut on the flange - M2.5 insert (only for shell style 0 & 2) - for more details, please see page 45-48

Range presentation

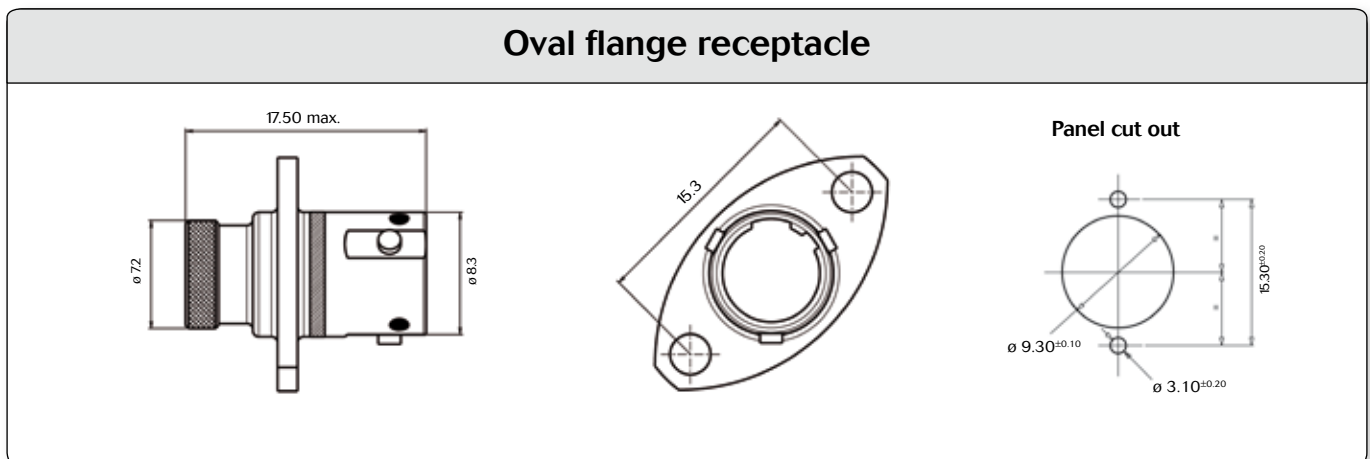
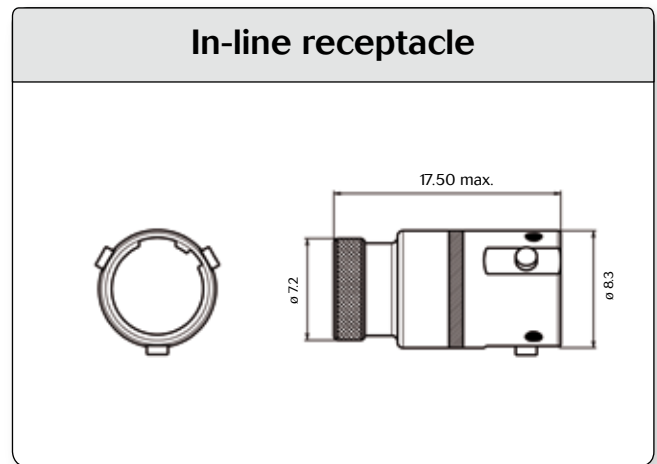
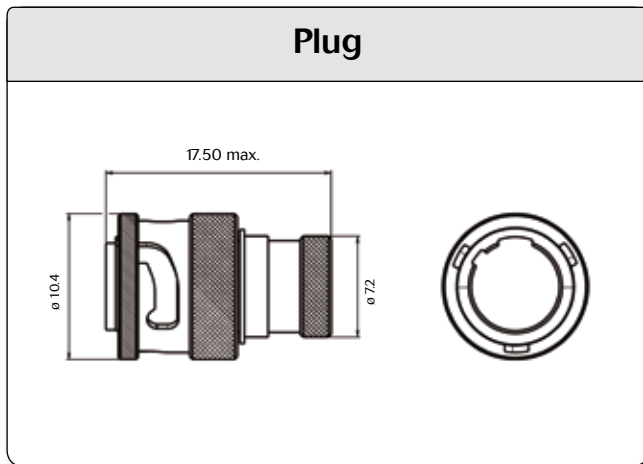



8STA shell size 02

Oval flange receptacle with PCB contacts

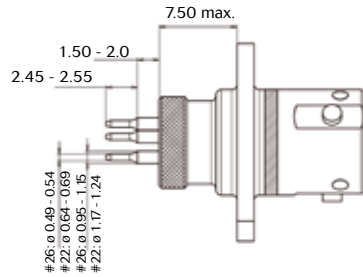

Panel cut out

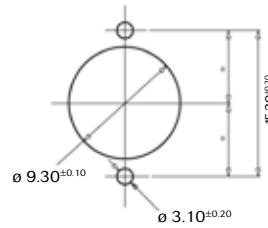

Grounded receptacle

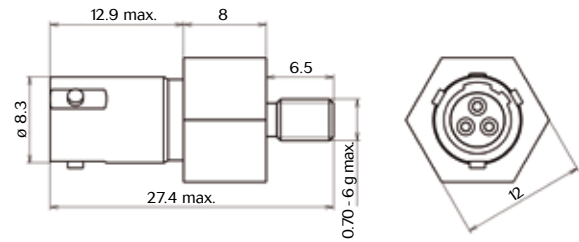

Please consult us for more information

Orientation

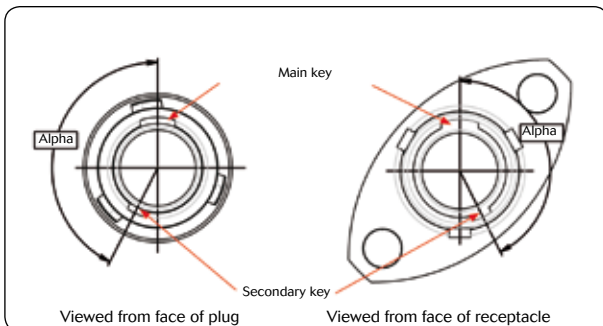

Key positions	Alpha	Colour band
N	153°	RED
A	51°	YELLOW
B	102°	BLUE
C	204°	ORANGE
D	255°	GREEN
E	306°	GREY

Main key remains fixed. 8STA 02-05 & 8STA 02-35 have the same orientations. Keyways width dimensions are different to avoid wrong mating in blind conditions.

8STA shell size 02





Contacts

Crimped & PCB contacts									
Contact size	Contact type	Contact \varnothing	Part numbers	Admissible wire section				External dia. over insulation (mm)	
				AWG		mm ²		Min.	Max.
Crimp contact				Min.	Max.	Min.	Max.	Min.	Max.
22D	Male	0.76	8599-0702-JJ	28	22	0.095	0.38	0.71	1.37
	Female		8599-0710-900						
26	Male	0.50	8599 1001-JL	30	24	0.095	0.24	0.60	0.83
	Female		8599 1002-900						

PCB contact		Part numbers	
22D	Male	0.76	8599 1031-JJ
	Female		8599 1032-900
26	Male	0.50	8599 1004-JL
	Female		8599 1005-900

Crimping tools				
Contact size	Wire sizes	Type	Locator part number	Tool part number
22D	22 to 28	Male	8476 09	M22520/2-01
		Female	8476 06	
26	24 to 30	Male	640 088	
		Female	640 089	

Accessories

Insertion & extraction tools					
 M81969/14-01	 8599-1006	Contact size	Part numbers	Colour	
				Insertion	Extraction
		22D	M81969/14-01 (plastic)	Green	White
		26	8599-1006 (metallic)	Extraction only	

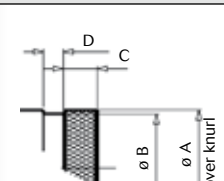
Shrinkable termination detail				
	$\varnothing A$	$B^{\pm 0.05}$	$C^{\pm 0.05}$	$D^{\pm 0.05}$
	7.2	6.55	2.2	2.30

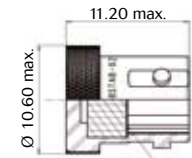
Metal protective cap	
Plug cap: 8STA802 11.20 max. 	Receptacle cap: 8STA902 9.80 max. 