

REV. SYM.		EI	DESCRIPTION		BY	APPD.
		M			DATE	DATE
A			ORIG. RELEASE		<i>AME</i>	<i>1/9/86</i>
B ₁	3259		ADD'G TO STAMPING & DATAPLATE P/N		<i>AME</i>	<i>3/10/86</i>
B ₂			REDESIGN DATAPLATE		<i>R/12/86</i>	

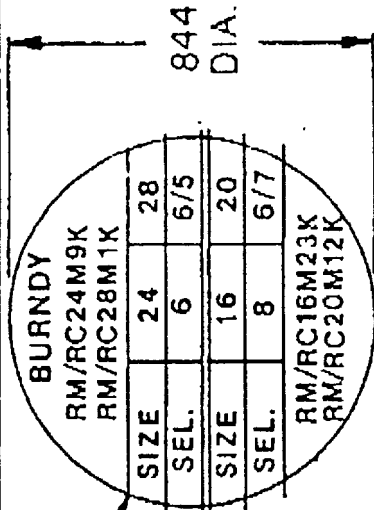

ITEM	PART NO.	REQ'D	DESCRIPTION
6	6-1048	2	.043 DIA X 129 P/N
5	8-1036	1	SPRING
4	1-1015	1	1/4-28 X 1/8 JAM SCREW
3	MH750-142A-B	1	BODY (GREEN)
2	86-164G-DP	1	DATAPLATE
1	MH750-141	1	INSERT

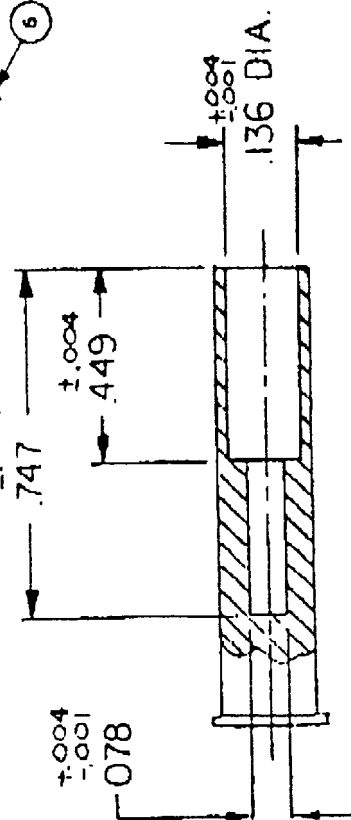
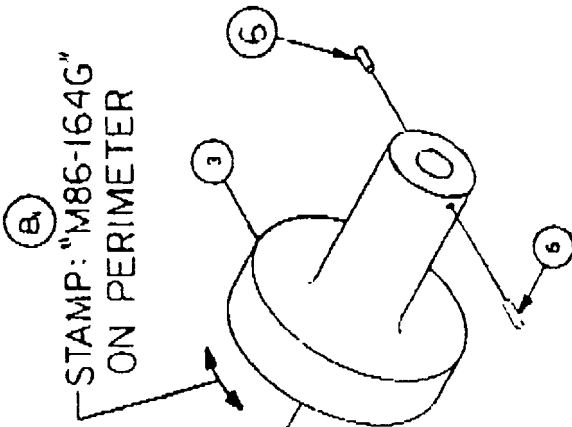

ITEM	PART NO.	REQ'D	DESCRIPTION/REMARKS
DRN.	<i>AME</i>		
CHK'D.	<i>AME</i>		
APP'D.	<i>AME</i>		
DATE	<i>1/9/86</i>		
DATE	<i>1/9/86</i>		
DATE	<i>1/9/86</i>		
DATE	<i>1/9/86</i>		
UNLESS OTHERWISE SPECIFIED TOLERANCE Fractions 3/32 Angles 3W Decimals .1: ±.030 - .XX: ±.010 .XXX: ±.005 - .XXXX: ±.0004 REMOVE BURRS & BREAK SHARP EDGES .093-.015			
MATERIAL		DANIELS MANUFACTURING CORP. ORLANDO, FLORIDA FORM 1186A	
HEAT TREAT		POSITIONER	
FINISH		WHERE USED: SIZE SCALE SUPERSEDES A NTS POSTING <i>1/2</i> P/N 86-164G	
		REV. B	

RESTRICTED & CONFIDENTIAL INFORMATION
PROPRIETARY RIGHTS INVOLVED

This document is transmitted by DANIELS MANUFACTURING CORP. (DANIELS) with the following understanding and agreement: By acceptance of this (these) document(s) recipient agrees that all rights in and to this document and the information contained herein are reserved by DANIELS and will not be copied, duplicated, used, sold, or disclosed to others without the express written permission of DANIELS, nor will devices embodying such information be manufactured, used, sold or disclosed to others without the express written permission of DANIELS.

This document belongs to and shall be returned to DANIELS upon request.

**THIS DRAWING IS FOR
MILES ROYSTONE USE ONLY.**
It is not to be released to customer
or other parties without express written
consent from DMG.