

# Customer Information Sheet

DRAWING No.: T1563F46

SHEET 2 OF 2

IF IN DOUBT - ASK



NOT TO SCALE

THIRD ANGLE PROJECTION

ALL DIMENSIONS IN mm

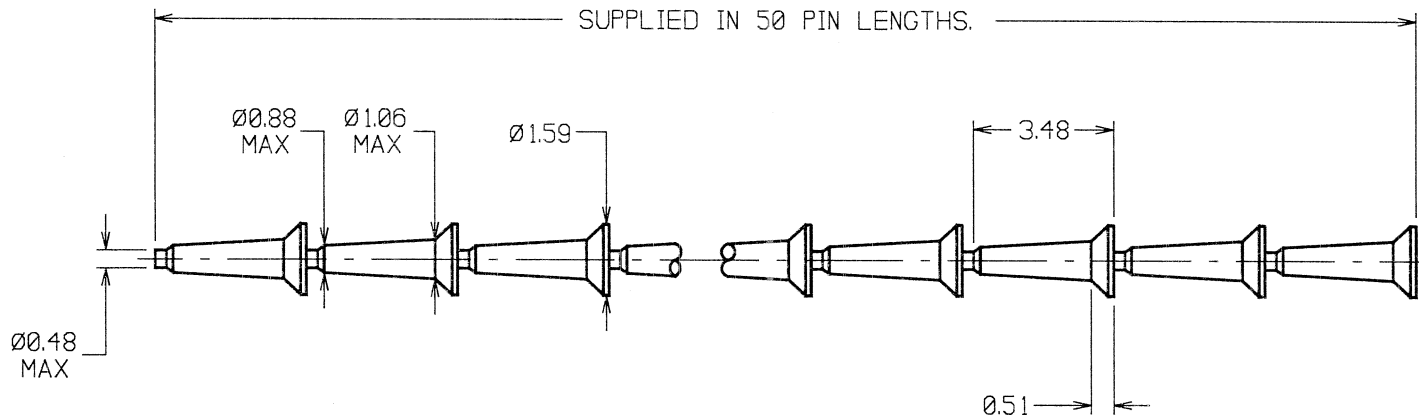

NOTES:

1. STRIPS ARE PACKED IN BOXES, 10 STRIPS PER BOX, (QUANTITY 500 PINS PER BOX).
2. USE WITH TRACK PIN INSERTION TOOL Z1002-00. AND INSTRUCTION SHEET IS-06.
3. THESE ITEMS ARE RoHS COMPLIANT.

MGP	1	15.02.06	9029
NAME	ISS.	DATE	C/NOTE
APPROVED: <i>[Signature]</i>			
CHECKED: <i>[Signature]</i>			
DRAWN:		MARK G PLESTED	
CUSTOMER REF.:			
ASSEMBLY DRG:			

## HARWIN

HARWIN USA  
TEL: 603 893 5376  
FAX: 603 893 5396  
mis@harwin.com

HARWIN Europe (UK)  
TEL: 023 9231 4545  
FAX: 023 9231 4590  
mis@harwin.co.uk

HARWIN Asia  
TEL: +65 6 779 4909  
FAX: +65 6 779 3868  
mis@harwin.com.sg

THIS DRAWING AND ANY INFORMATION OR DESCRIPTIVE MATTER SET OUT HEREON ARE CONFIDENTIAL AND COPYRIGHT PROPERTY OF THE HARWIN GROUP AND MUST NOT BE DISCLOSED, LOANED, COPIED OR USED FOR MANUFACTURING, TENDERING OR FOR ANY OTHER PURPOSE WITHOUT THEIR WRITTEN PERMISSION

TOLERANCES  
X. -  $\pm 1\text{mm}$   
X.X -  $\pm 0.25\text{mm}$   
X.XX -  $\pm 0.10\text{mm}$   
X.XXX -  $\pm 0.01\text{mm}$   
ANGLES -  $\pm 5^\circ$   
UNLESS STATED

MATERIAL:  
BRASS CW614N M (CuZn39Pb3)  
TO BS EN 12164  
FINISH: 100% TIN  
S/AREA: mm<sup>2</sup>

TITLE:  
CONTINUOUS TRACK PIN.  
DRAWING NUMBER:  
T1563F46

SHT  
2  
OF  
2

# Customer Information Sheet

DRAWING No.: T1563F46K

SHEET 2 OF 2

IF IN DOUBT - ASK



NOT TO SCALE

THIRD ANGLE PROJECTION

ALL DIMENSIONS IN mm

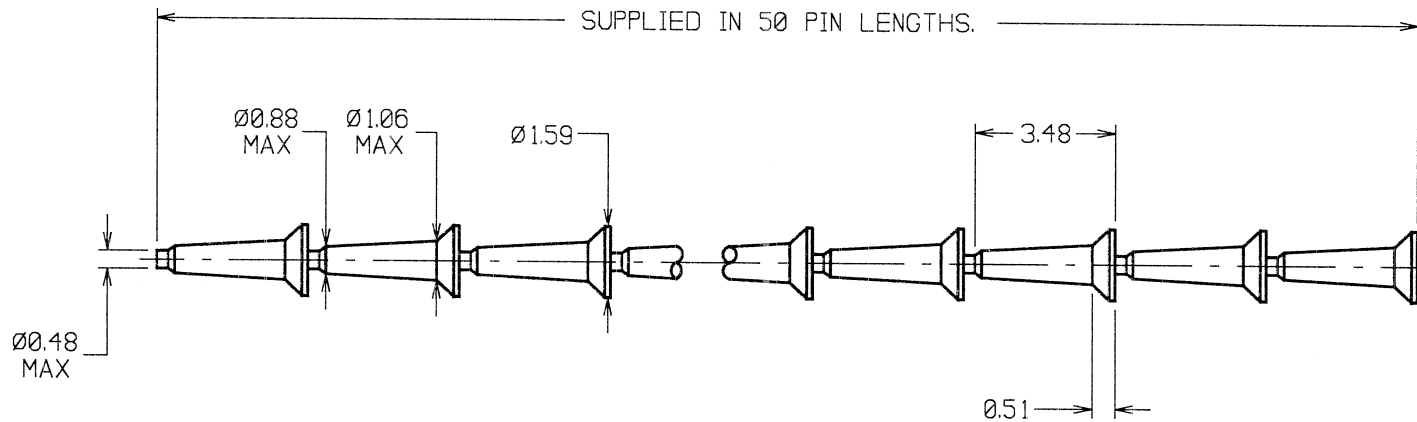

NOTES:

1. STRIPS ARE PACKED IN BOXES, 20 STRIPS PER BOX, (QUANTITY 1000 PINS PER BOX).
2. USE WITH TRACK PIN INSERTION TOOL Z1002-00. AND INSTRUCTION SHEET IS-06.
3. THESE ITEMS ARE RoHS COMPLIANT.

MGP	1	15.02.06	9029
NAME	ISS.	DATE	C/NOTE
APPROVED: <i>[Signature]</i>			
CHECKED: <i>[Signature]</i>			
DRAWN: MARK G PLESTED			
CUSTOMER REF.:			
ASSEMBLY DRG.:			

## HARWIN

THIS DRAWING AND ANY INFORMATION OR DESCRIPTIVE MATTER SET OUT HEREON ARE CONFIDENTIAL AND COPYRIGHT PROPERTY OF THE HARWIN GROUP AND MUST NOT BE DISCLOSED, LOANED, COPIED OR USED FOR MANUFACTURING, TENDERING OR FOR ANY OTHER PURPOSE WITHOUT THEIR WRITTEN PERMISSION.

TOLERANCES

X. - ±1mm  
 X.X - ±0.25mm  
 X.XX - ±0.10mm  
 X.XXX - ±0.01mm  
 ANGLES - ±5°  
 UNLESS STATED

MATERIAL:

BRASS CW614N M (CuZn39Pb3)  
 TO BS EN 12164

FINISH: 100% TIN

S/AREA: mm<sup>2</sup>

TITLE:

CONTINUOUS TRACK PIN.

DRAWING NUMBER:

T1563F46K

HARWIN USA  
 TEL: 603 893 5376  
 FAX: 603 893 5396  
 mis@harwin.com

HARWIN Europe (UK)  
 TEL: 023 9231 4545  
 FAX: 023 9231 4590  
 mis@harwin.co.uk

HARWIN Asia  
 TEL: +65 6 779 4909  
 FAX: +65 6 779 3868  
 mis@harwin.com.sg

SHT  
 2 OF 2