

F²MC-16FX FAMILY EVALUATION BOARD SK-96320-80PMC

USER GUIDE

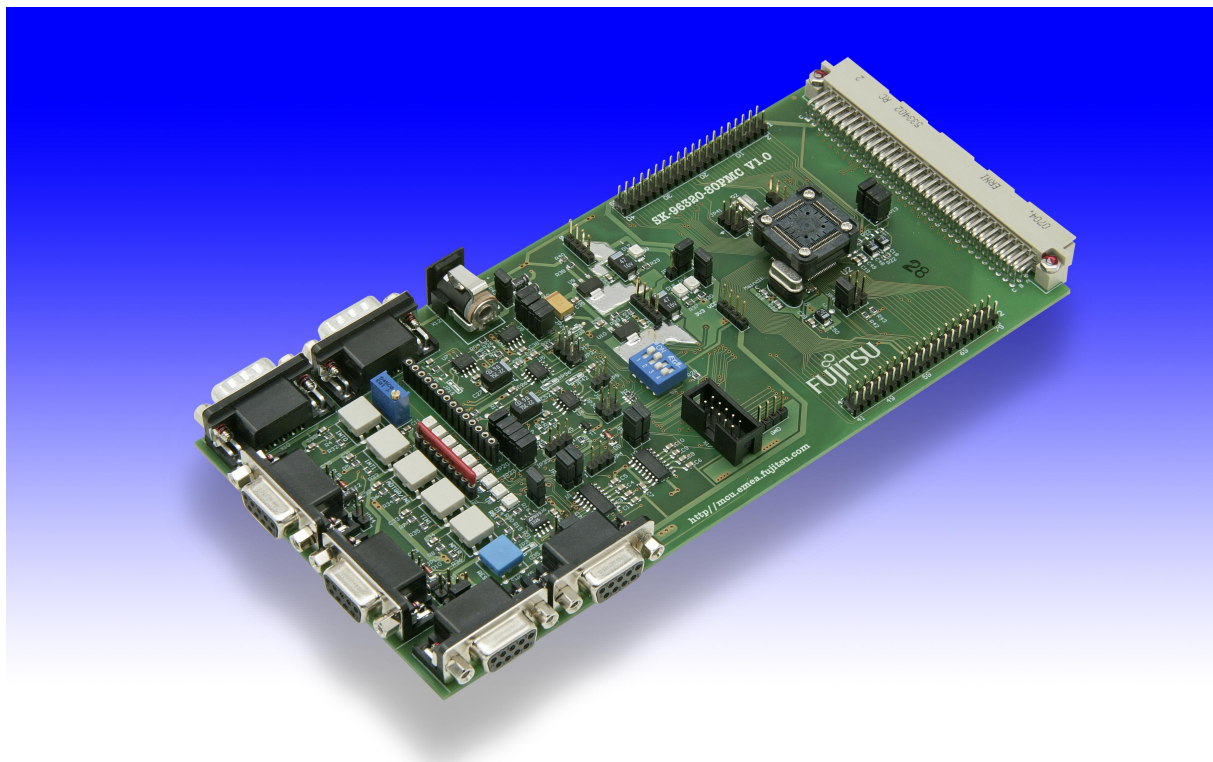

Revision History

Date	Issue
06.07.2007	V1.0, HWe/DGo, First Release
08.02.2008	V1.1, HWe, China-RoHS regulation added
01.04.2008	V1.2, HWe, Chapter 5.7 corrected (Pin 55 - 57)

This document contains 34 pages.

Warranty and Disclaimer

To the maximum extent permitted by applicable law, Fujitsu Microelectronics Europe GmbH restricts its warranties and its liability for **the SK-96320-80PMC Board and all its deliverables** (eg. software include or header files, application examples, target boards, evaluation boards, engineering samples of IC's etc.), its performance and any consequential damages, on the use of the Product in accordance with (i) the terms of the License Agreement and the Sale and Purchase Agreement under which agreements the Product has been delivered, (ii) the technical descriptions and (iii) all accompanying written materials. In addition, to the maximum extent permitted by applicable law, Fujitsu Microelectronics Europe GmbH disclaims all warranties and liabilities for the performance of the Product and any consequential damages in cases of unauthorised decompiling and/or reverse engineering and/or disassembling. **Note, the SK-96320-80PMC Board and all its deliverables are intended and must only be used in an evaluation laboratory environment.**

1. Fujitsu Microelectronics Europe GmbH warrants that the Product will perform substantially in accordance with the accompanying written materials for a period of 90 days from the date of receipt by the customer. Concerning the hardware components of the Product, Fujitsu Microelectronics Europe GmbH warrants that the Product will be free from defects in material and workmanship under use and service as specified in the accompanying written materials for a duration of 1 year from the date of receipt by the customer.
2. Should a Product turn out to be defect, Fujitsu Microelectronics Europe GmbH's entire liability and the customer's exclusive remedy shall be, at Fujitsu Microelectronics Europe GmbH's sole discretion, either return of the purchase price and the license fee, or replacement of the Product or parts thereof, if the Product is returned to Fujitsu Microelectronics Europe GmbH in original packing and without further defects resulting from the customer's use or the transport. However, this warranty is excluded if the defect has resulted from an accident not attributable to Fujitsu Microelectronics Europe GmbH, or abuse or misapplication attributable to the customer or any other third party not relating to Fujitsu Microelectronics Europe GmbH.
3. To the maximum extent permitted by applicable law Fujitsu Microelectronics Europe GmbH disclaims all other warranties, whether expressed or implied, in particular, but not limited to, warranties of merchantability and fitness for a particular purpose for which the Product is not designated.
4. To the maximum extent permitted by applicable law, Fujitsu Microelectronics Europe GmbH's and its supplier's liability are restricted to intention and gross negligence.

NO LIABILITY FOR CONSEQUENTIAL DAMAGES

To the maximum extent permitted by applicable law, in no event shall Fujitsu Microelectronics Europe GmbH and its suppliers be liable for any damages whatsoever (including but without limitation, consequential and/or indirect damages for personal injury, assets of substantial value, loss of profits, interruption of business operation, loss of information, or any other monetary or pecuniary loss) arising from the use of the Product.

Should one of the above stipulations be or become invalid and/or unenforceable, the remaining stipulations shall stay in full effect

0 Contents

REVISION HISTORY	2
WARRANTY AND DISCLAIMER	3
0 CONTENTS	4
1 OVERVIEW	6
1.1 Abstract.....	6
1.2 Features.....	6
1.3 General Description.....	7
2 INSTALLATION	9
Default Jumper settings for MB96320.....	10
3 JUMPERS AND SWITCHES	12
3.1 Operating Mode (S2).....	12
3.2 Power Supply (JP: 29, 37, 43, 44, 45)	13
3.3 Analog Power Supply Voltage (JP: 11, 13, 15).....	14
3.4 Subclock (JP: 34, 41)	15
3.5 UART"A" (JP: 1, 2, 31)	16
3.6 UART"B" (JP: 6, 8, 32)	16
3.7 LIN"A" (JP: 17, 18, 21, 22, 44).....	17
3.8 LIN"B" (JP: 9, 10, 38, 39, 45).....	18
3.9 CAN"A" (JP: 19, 25, 26).....	18
3.10 CAN"B" (JP: 27, 28)	19
3.11 I ² C Pull-Up (JP: 46, 47)	19
3.12 C-Pin Capacitor	19
3.13 Reset-Generation (JP: 3, 4, 5, 7, 24, 35)	20
3.14 Buttons SW1, SW2, SW3, SW4, SW5, SW6 (JP: 12, 14, 16, 20, 23, 24)	21
4 PROGRAMMING THE INTERNAL FLASH MEMORY	22
4.1 Asynchronous Mode.....	22
4.2 Synchronous Mode	24
5 CONNECTORS	25
5.1 Power connector (X12).....	25
5.2 Edge connector (X1, X2)	25
5.3 UART"A", UART"B" connector (X3, X5).....	25
5.4 LIN"A", LIN"B" Interface connector (X6, X8)	26
5.5 CAN"A", CAN"B" Interface connector (X10, X11).....	26
5.6 USER-LEDs & optional LC-Display	26

5.7	VG96 connector (X4).....	27
6	SILK-PLOT OF THE BOARD	28
7	REVISION AND ERROR LIST	29
8	RELATED PRODUCTS	30
9	INFORMATION IN THE WWW.....	31
10	CHINA-ROHS REGULATION	32
11	RECYCLING	34

1 Overview

1.1 Abstract

The SK-96320-80PMC is a multifunctional evaluation board for the Fujitsu 16-bit Flash microcontroller series MB96320.

It can be used stand-alone for software development and testing or as a simple target board to work with the emulator system.

The board allows the designer immediately to start software development before his own final target system is available.

1.2 Features

- ▶ Supports Fujitsu's MB96320 Series in FPT-80P-M21 package or the MB2198 Emulator System with the Probe Cable MB2198-505
- ▶ 9-12V unregulated external DC power supply
- ▶ 5V and 3.3V onboard voltage regulators
 - ▶ Power-LEDs
 - ▶ Onboard voltage supervisor monitor
- ▶ In-Circuit serial Flash programming
- ▶ All resources available for evaluation
- ▶ All MCU pins routed to edge connectors
- ▶ 4 MHz main crystal
- ▶ 32 kHz crystal for sub clock operation
- ▶ Two RS232, two LIN and two CAN interface are usable simultaneously
- ▶ 3V capable CAN, LIN and RS232 transceivers
- ▶ 8 User LEDs, optional: alphanumeric standard LC-Display connectable instead of LEDs
- ▶ Reset button, Reset LED
- ▶ 5 User buttons
- ▶ 96-pin VG connector featuring most MCU signals (DIN 41612)

**This board must only be used for test applications
in an evaluation laboratory environment.**

1.3 General Description

The SK-96320-80PMC supports the 16-bit Flash microcontroller MB96320 Series.

It can be used as a stand-alone evaluation board or as a target board for the emulator debugger.

The evaluation board supports the following package: FPT-80P-M21.

The board is supplied with a socketed 4 MHz crystal as main oscillation source. Using the internal PLL of the μ C, higher internal clock rates up to 56 MHz can be achieved.

Two separate RS232 transceivers are available to connect two on-chip UARTs to 9-pin D-Sub connectors (X3, X5). The transceivers generate the adequate RS232 levels for the receive (RXD) and transmit (TXD) lines. Either the DTR line or the RTS line can be selected with jumpers (JP3, JP4, and JP5) to generate a system reset. The RTS signal can be shortcut to CTS using the jumpers JP31 and JP32.

In-circuit programming (asynchronous) can be done via UART"A" (X3) or UART"B" (X5).

Two single-wire LIN-transceivers (TLE7259) are available to connect two on-chip UARTs to 9-pin D-Sub connectors (X6, X8). The transceivers generate the adequate levels to drive the bus line in LIN systems for automotive and industrial applications. The LIN Vs line can be powered by the unregulated supply input of the board, so no additional supply is needed.

Two high-speed CAN transceiver (TLE6250GV33) are connected to the CAN interface of the MCU to allow easy connection to CAN networks.

All transceivers are fully 3.3V IO compatible to enable low voltage applications.

All pins of the microcontroller except the oscillator pins X0/1(A) are connected to the edge connectors X1 and X2 and are directly available to the user. Furthermore, most signals are available on the VG96 connector X4.

The on-board voltage regulators allow the user to connect an unregulated DC input voltage of +9V up to +12V. In case of any modifications of the board, care should be taken that the total power consumption will not overheat the voltage regulators. Maximum output current for VCC on connector X4 = 50 mA.

There are six push button switches on the board, which can be connected to input ports of the microcontroller. This allows the user to evaluate external Interrupts, external ADC trigger or Input Capture functions as well as simple input polling. One button is reserved as 'Reset'-button for the microcontroller, controlled by the supply monitor IC.

Eight user LEDs are connected to Port 6 and grounded by a 1K resistor network. If these LEDs are not required, the resistor network can be removed to disconnect the LEDs and to free the IO port.

Two additional pull-up resistors R42 and R43 can be connected to the I²C bus lines by setting the according Jumpers (JP46, JP47).

1.3.1 Emulator System

If the board is used as an emulator target board, the microcontroller must be removed from the socket and the corresponding probe cable has to be mounted:

Series	V-Chip	Probe cable	NQ-Pack	HQ-Pack
MB96320	MB96V300B	MB2198-505	NQPACK080SD-ND	HQPACK080SD

2 Installation

Carefully remove the board from the shipping carton.

First, check if there are any damages before powering up the evaluation board.

For the power supply a DC input voltage of 9V – 12V is recommended. The positive voltage (+) must be connected to the shield, and ground (GND) must be connected to the center pin of the connector X12!

Special care must be taken to the maximum input voltage, if the LIN Vs lines are supplied by the board (JP44/JP45), since the input supply voltage is directly applied to pin 1 of X6 / X8 without a voltage regulator.

After power-on, the yellow power-on LED's (D16, D17, D18) should be lit. If the LED's do not light up, switch off the power supply and check input polarity and the settings of JP43, JP29 and JP37.

The in-circuit programming allows the user to program own applications into the Flash memory. The procedures for Flash programming are described in chapter 4.

If the board shall be used as an emulator target board, switch off the power supply and remove the microcontroller from the socket. Now the probe cable can be mounted on the socket. Take care of the pin 1 marking on the socket and fasten the probe cable with the provided screws.

Do not use any other probe cable than MB2198-505 only!

Connect the probe cable to the MB2198-300 emulation Adapter Board. Check all jumper settings of the evaluation board (especially JP29), the Probe Cable and the Adapter Board.

When turning on the system, be sure to use the following power-up sequence:

1. Power up the emulator main unit (MB2198-01)
2. Power up the adapter board (MB2198-500)
3. Power up the target board (SK-96320-80PMC)

To turn off the system, switch off the components in reverse order, beginning with the target board.

Please refer to the corresponding user manuals and application notes for the emulator how to set up the emulator system. After power on, the 'Reset'-LED (D14) the emulator must be off and the 'Vcc'-LED must be on.

If the Reset LED is still lit, check the DIP-switch settings of the emulator system and the power supply of the evaluation board.

Note:

Some customers experience connectivity problems when connecting the MCU into the socket adapter. Only the small red screwdriver available in your box should be used to connect the cover (HQPAC) onto the socket (NQPACK).

If the four screws are not tightening equally, then it may cause a poor contact.

Do not screw the cover too tight (max 0.054 Nm). If you have connectivity problems then please loosen the screws and tighten again the screws equally.

Do not clean NQPACK, YQPACK, and YQSOCKET with steam. Cleaning material will contaminate inside of connector.

Default Jumper settings for MB96320

Jumper	Description / Function	Type	Default Setting	Coordinates
JP1	UART A (TXD) SOT2	Jumper 2 pin	Closed	E7
JP2	UART A (RXD) SIN2	Jumper 2 pin	Closed	E8
JP3	DTR/RTS A	Jumper 3 pin	Open	E3
JP4	RESET UART A/B	Jumper 3 pin	Open	E8
JP5	DTR/RTS B	Jumper 3 pin	Open	E6
JP6	UART B (RXD) SIN3	Jumper 2 pin	Closed	F9
JP7	Direct/Delay Reset	Solder JP 3 pin	1-2	E5
JP8	UART B (TXD) SOT3	Jumper 2 pin	Closed	F9
JP9	LIN B enable	Jumper 2 pin	Open	G10
JP10	LIN B Master mode	Jumper 2 pin	Open	H3
JP11	AVcc	Jumper 2 pin	Closed	G19
JP12	SW1	Jumper 2 pin	Closed	G7
JP13	AVcc=AVRH	Jumper 2 pin	Closed	G19
JP14	SW2	Jumper 2 pin	Closed	G7
JP15	AVss	Jumper 2 pin	Closed	H19
JP16	SW3	Jumper 2 pin	Closed	G7
JP17	LIN A enabled	Jumper 2 pin	Open	H17
JP18	LIN A Master mode	Jumper 2 pin	Open	H3
JP19	VCC CAN-transceiver, CAN A	Solder JP 3 pin	1-2	I7
JP20	SW4	Jumper 2 pin	Closed	G7
JP21	LIN A (TXD) SIN7R	Jumper 2 pin	Open	H10
JP22	LIN A (RXD) SOT7R	Jumper 2 pin	Open	H10
JP23	SW5	Jumper 2 pin	Closed	F7
JP24	Reset	Jumper 2 pin	Closed	F7
JP25	CAN A (TXD) TX1	Jumper 2 pin	Closed	H10
JP26	CAN A (RXD) RX1	Jumper 2 pin	Closed	I10
JP27	CAN B (TXD) TX2	Jumper 2 pin	Closed	I10
JP28	CAN B (RXD) RX2	Jumper 2 pin	Closed	I10
JP29	Vcc 5V / 3V3	Jumper 3 pin	1-2	H14
JP31	RTS-CTS A	Jumper 2 pin	Closed	D3
JP32	RTS-CTS B	Jumper 2 pin	Closed	D6
JP33	VCC CAN-transceiver, CAN B	Solder JP 3 pin	1-2	I11
JP34	X1A select	Jumper 3 pin	1-2	I17
JP35	DTR / DTRx	Jumper 3 pin	Open	F8
JP36	TLE6259(2-3)/TLE7259(1-2) "WAKE"	Solder JP 3 pin	1-2	H9
JP37	MCU_Vcc	Jumper 2 pin	Closed	H14
JP38	LIN B (RXD) SIN8R	Jumper 2 pin	Open	F10
JP39	LIN B (TXD) SOT8R	Jumper 2 pin	Open	F10
JP40	C-Pin to MCU_VCC	Jumper 2 pin	Closed	F16
JP41	X0A select	Jumper 4 pin	1-2	I16
JP42	TLE6259(2-3)/TLE7259(1-2) "WAKE"	Solder JP 3 pin	1-2	G10
JP43	Power	Jumper 2 pin	Closed	J10
JP44	LIN VBat A	Jumper 2 pin	Open	G3
JP45	LIN VBat B	Jumper 2 pin	Open	E3
JP46	SDA0 Pull-Up	Jumper 2 pin	Open	F16
JP47	SCL0 Pull-Up	Jumper 2 pin	Open	F16

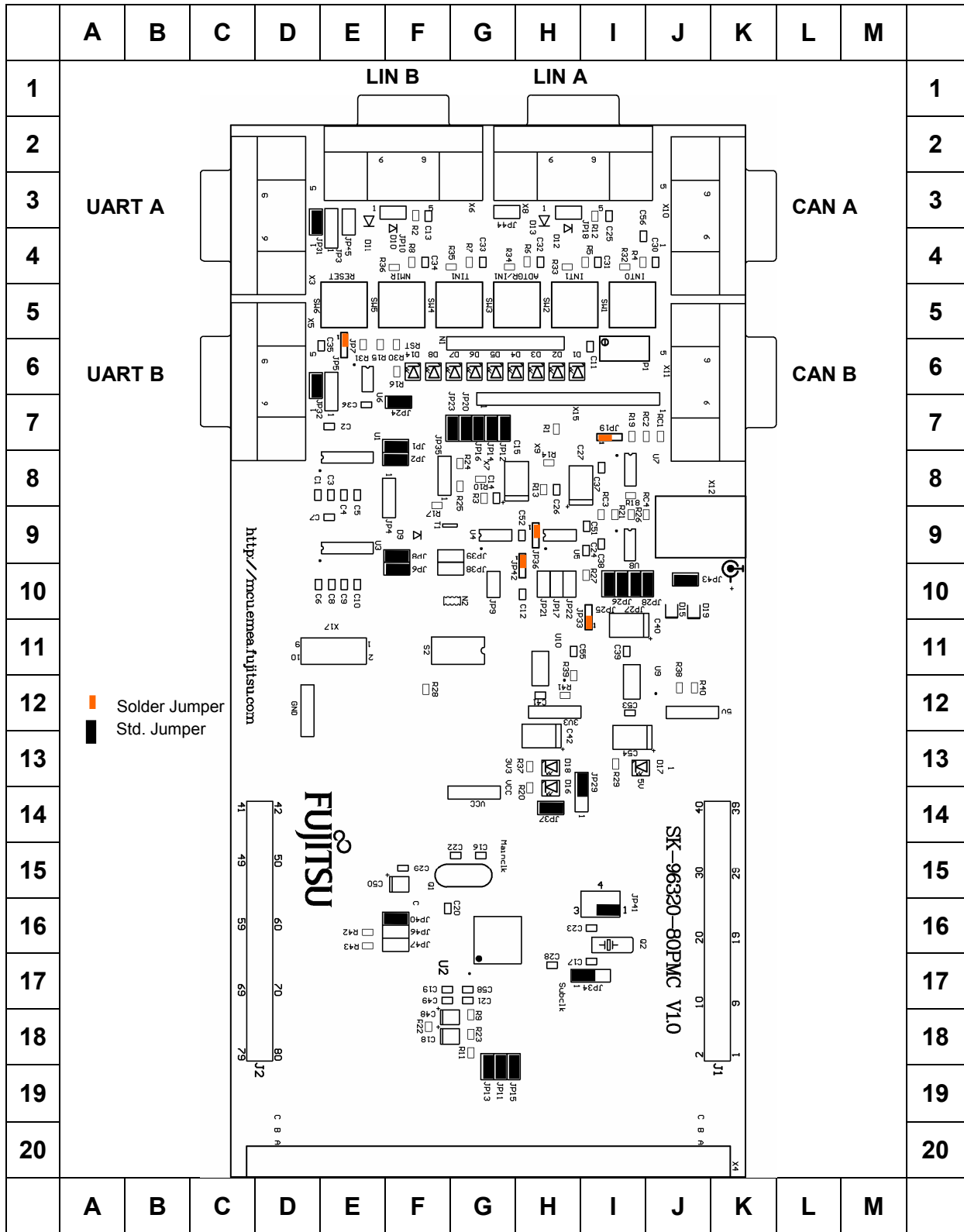

3 Jumpers and Switches

This chapter describes all jumpers and switches that can be modified on the evaluation board. The default setting (MB96320 Series) is shown with a grey shaded area.

3.1 Operating Mode (S2)

The DIP-switch S2 is used to set the operating mode of the μ C. Ensure that the mode pin settings correspond to the operation-mode of the application. For more detailed information please check the Hardware-Manual of the microcontroller.

DIP switch	Setting	Logical value
S2/1 (MD0)	ON (closed)	1 (high)
	OFF (open)	0 (low)
S2/2 (MD1)	ON (closed)	1 (high)
	OFF (open)	0 (low)
S2/3 (MD2)	ON (closed)	1 (high)
	OFF (open)	0 (low)
S2/4	not connected	

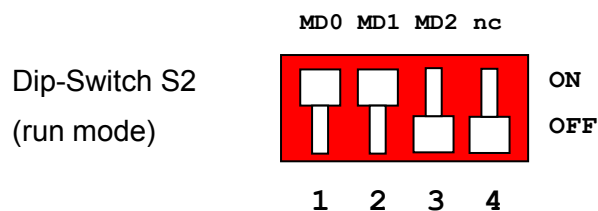

3.2 Power Supply (JP: 29, 37, 43, 44, 45)

Two onboard voltage regulators provide stabilized 5V and 3.3V supplies to the MCU and peripherals. Even though they are thermally protected against overload, care must be taken when supplying current for additional circuitry.

The LIN Vs line can be connected directly to the input supply of the board by JP44 and JP45. In this case, the input voltage to the board has to be suitable for the connected bus devices (mostly around 12V). Since there is a protection diode between Vin and Vs, it is not possible to power the board over the LIN bus.

JP29 Selects the MCU IO and peripherals Vcc voltage (3.3V or 5V)

JP37 Connects the MCU IO voltage to Vcc. Could be used for current measurement.

JP43 Main supply on / off

JP44 Connects LIN Vs (Pin 1 of X8) to Vin

JP45 Connects LIN Vs (Pin 1 of X6) to Vin

Jumper	Setting	Description
JP29 (VDD5 3V/5V)	1 - 2	MCU / Peripherals @ 5V
	2 - 3	MCU / Peripherals @ 3.3V
JP37 (VDD5)	Closed	Power supply Vcc connected to VDD5
	Open	Power supply Vcc not connected to VDD5
JP43 (Mains on/off)	Closed	The board is switched on
	Open	The board is switched off
JP44 (VBAT_A)	Closed	Vs of LIN A is powered by the board
	Open	No voltage supply to Vs of LIN A
JP45 (VBAT_B)	Closed	Vs of LIN B is powered by the board
	Open	No voltage supply to Vs of LIN B

3.3 Analog Power Supply Voltage (JP: 11, 13, 15)

The power supply as well as the positive reference voltage for the A/D-converter can be provided internally or externally.

JP11, JP15 connects analog power supply voltages (AVcc and AVss)

JP13 connects the analog reference voltage AVRH to AVcc

Jumper	Setting	Description
JP11 (AVcc)	Closed	AVcc is connected to Vcc
	Open	AVcc is disconnected from Vcc
JP13 (AVRH)	Closed	AVRH is connected to AVcc
	Open	AVRH defined by resistor network ^{*1}
JP15 (AVss)	Closed	AVss is connected to GND
	Open	AVss is disconnected from GND

^{*1}By default the resistors R11 and R23 are not mounted on the board

Default: JP11, JP13 and JP15 are closed

By default, the A/D-converter supply and reference voltage is same as the microcontroller supply voltage.

Note:

If JP11 and JP15 are open, the user has to supply an adequate analog voltage supply (AVcc and AVss) to the A/D-converter.

If JP13 is open, the resistors R11 and R23 define AVRH.

By default the resistors R11 and R23 are not mounted on the board.

3.4 Subclock (JP: 34, 41)

Some devices like e.g. MB96F326RW support a 32 kHz subclock (X0A, X1A), you can choose to not support subclock and use these pins as additional port-pins (e.g. P40, P41) instead.

Please check the related datasheet.

JP41: defines usage of Pin 24 (X0A/P40)

JP34: defines usage of Pin 25 (X1A/P41)

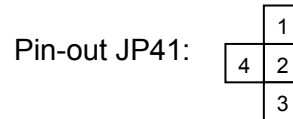

Jumper	Setting	Description
JP41 (X0A, P40)	1-2	Pin 24 is connected to the 32kHz Subclock (X0A)
	2-4	Pin 24 is used as P4_0 and is connected to X4-B10
	2-3	Pin 24 is connected to GND (in case that subclock-device is used, but no 32kHz crystal is connected)
JP34 (X1A, P41)	1-2	Pin 25 is connected to the 32kHz Subclock (X1A)
	2-3	Pin 25 is used as P4_1 and is connected to X4-C9

Default: JP41: 1-2, JP34: 1-2

By default, the 32 kHz-subclock-crystal is connected to the microcontroller.

3.5 UART"A" (JP: 1, 2, 31)

One RS232-transceiver (U1, X3) can be connected to one of the microcontroller's UART interfaces.

JP1, JP2 connect UART 2 to the RS232-transceiver (U1, X3)

JP31 Some programs (e.g. Terminals) need a connection between CTS and RTS

Jumper	Setting	Description
JP2 (UART"A"RxD)	Closed	SIN2 of the MCU is connected to UART"A"
	Open	SIN2 of the MCU is not connected to UART"A"
JP1 (UART"A"TxD)	Closed	SOT2 of the MCU is connected to UART"A"
	Open	SOT2 of the MCU is not connected to UART"A"
JP31 (RTS-CTS)	Closed	RTS and CTS of X3 are connected
	Open	RTS and CTS of X3 are not connected

By default, UART2 is connected to UART"A".

3.6 UART"B" (JP: 6, 8, 32)

One RS232-transceiver (U3, X5) can be connected to one of the microcontroller's UART interfaces.

JP6, JP8 connect UART 3 to the RS232-transceiver (U3, X5)

JP32 Some programs (e.g. Terminals) need a connection between CTS and RTS

Jumper	Setting	Description
JP6 (UART"B"RxD)	Closed	SIN3 of the MCU is connected to UART"B"
	Open	SIN3 of the MCU is not connected to UART"B"
JP8 (UART"B"TxD)	Closed	SOT3 of the MCU is connected to UART"B"
	Open	SOT3 of the MCU is not connected to UART"B"
JP32 (RTS-CTS)	Closed	RTS and CTS of X5 are connected
	Open	RTS and CTS of X5 are not connected

By default, UART3 is connected to UART"B".

UART "B" can be used for serial asynchronous Flash programming.

3.7 LIN"A" (JP: 17, 18, 21, 22, 44)

One LIN-transceiver (U5, X8) can be connected to one of the microcontroller's UART interfaces.

JP17 enable LIN-Transceiver

JP18 LIN Master-mode

JP21, JP22 connects UART 7 to the LIN-transceiver (U5, X8)
If the LIN interface is not used then the jumpers should be left open.

Jumper	Setting	Description
JP17 (LIN enable)	Closed	LIN-transceiver is enabled
	Open	LIN-transceiver is disabled
JP18 (LIN Master)	Closed	LIN Master-mode
	Open	LIN Slave-mode
JP21 (LIN"A"RXD)	Closed	SIN7 of the MCU is connected to LIN"A"
	Open	SIN7 of the MCU is not connected to LIN"A"
JP22 (LIN"A"TXD)	Closed	SOT7 of the MCU is connected to LIN"A"
	Open	SOT7 of the MCU is not connected to LIN"A"
JP44 (VBAT_A)	Closed	Vs of LIN A is powered by the board
	Open	No voltage supply to Vs of LIN A
JP36 (WAKE)	1-2	Connects WAKE signal to Bus power
	2-3	Connects WAKE signal to VCC

By default, the LIN"A"-interface is not connected to a UART.

3.8 LIN" B" (JP: 9, 10, 38, 39, 45)

One LIN-transceiver (U4, X6) can be connected to one of the microcontroller's UART interfaces.

JP9 enable LIN-Transceiver

JP10 LIN Master-mode

JP38, JP39 connects UART 1 to the LIN-transceiver (U4, X6)
If the LIN interface is not used then the jumpers should be left open.

Jumper	Setting	Description
JP9 (LIN enable)	Closed	LIN-transceiver is enabled
	Open	LIN-transceiver is disabled
JP10 (LIN Master)	Closed	LIN Master-mode
	Open	LIN Slave-mode
JP38 (LIN" B"RXD)	Closed	SIN8 of the MCU is connected to LIN" B"
	Open	SIN8 of the MCU is not connected to LIN" B"
JP39 (LIN" B"TXD)	Closed	SOT8 of the MCU is connected to LIN" B"
	Open	SOT8 of the MCU is not connected to LIN" B"
JP45 (VBAT_B)	Closed	Vs of LIN B is powered by the board
	Open	No voltage supply to Vs of LIN B
JP42 (WAKE)	1-2	Connects WAKE signal to Bus power
	2-3	Connects WAKE signal to VCC

By default, the LIN" B"-interface is not connected to a UART.

3.9 CAN" A" (JP: 19, 25, 26)

One high-speed CAN-transceiver can be connected to the microcontroller's CAN interface.

JP25, JP26 connects a CAN-port to the CAN-transceiver (U7, X10).
If the CAN interface is not used then the jumpers should be left open.

JP19 selects the power supply of the CAN A transceiver (5V / 3V3)

Jumper	Setting	Description
JP25 (CAN" A"TX)	closed	TX1 of MCU is connected to CAN" A"
JP26 (CAN" A"RX)	closed	RX1 of MCU is connected to CAN" A"
JP19 (VCC CAN A)	1-2	CAN A VCC is set to 5V
	2-3	CAN A VCC is set to 3V3

3.10 CAN“B” (JP: 27, 28)

One high-speed CAN-transceiver can be connected to the microcontroller’s CAN interface.

JP27, JP28 connects a CAN-port to the CAN-transceiver (U8, X11).

If the CAN interface is not used then the jumpers should be left open.

JP33 selects power supply of the CAN B transceiver (5V / 3V3)

Jumper	Setting	Description
JP27 (CAN“A”TX)	closed	TX2 of MCU is connected to CAN“B”
JP28 (CAN“A”RX)	closed	RX2 of MCU is connected to CAN“B”
JP33 (VCC CAN B)	1-2	CAN B VCC is set to 5V
	2-3	CAN B VCC is set to 3V3

3.11 I²C Pull-Up (JP: 46, 47)

Two 10k Ohm resistors can be connected to the SDA0 and SCL0 lines.

Jumper	Setting	Description
JP46 (SDA0)	closed	SDA0 is pulled up to VCC
JP47 (SCL0)	closed	SCL0 is pulled up to VCC

3.12 C-Pin Capacitor

For normal operation the C-pin must be connected to two capacitors. For test purposes you can disconnect these two capacitors.

Jumper	Setting	Description
JP40 (C-Pin)	closed	C-Pin is connected to capacitors for normal operation
	open	C-Pin is left open (not recommended for normal operation)

3.13 Reset-Generation (JP: 3, 4, 5, 7, 24, 35)

In addition to the internal Power-On reset, the microcontroller can be reset by an external reset circuit (Voltage Monitor) and also by a RS232 interface.

- JP3, JP5** As well the DTR-line as the RTS-Line of UART"A" or UART"B" can be used to generate a system reset.
- JP4** This jumper selects whether the DTR/RTS line from UART"A" or UART"B" will generate a system reset.
- JP7** This solder jumper selects between normal (immediate) reset and delayed reset. In delayed reset mode, the reset button has to be held down for 2 sec before a reset is generated to avoid accidental resets.
- JP24** Open this jumper if no external Reset shall be generated. In this case only the internal reset is active (e.g.: power-on)
- JP35** The signal on the DTR/RTS line can be negated with this jumper. Remove the jumper in order to disable the RS232 reset circuit.

Jumper	Setting	Description
JP3 (DTR / RTS "A")	1-2	DTR of UART"A" is selected
	2-3	RTS of UART"A" is selected
JP4 (UART"A"/"B")	1-2	UART"A" is used to generate Reset
	2-3	UART"B" is used to generate Reset
JP5 (DTR / RTS "B")	1-2	DTR of UART"B" is selected
	2-3	RTS of UART"B" is selected
JP7 (Reset imm./delayed)	1-2	Reset is applied immediately when SW6 is pressed
	2-3	Reset is applied when SW6 is pressed >2sec
JP24 (Main Reset)	Closed	External Reset generation is active
	Open	No external Reset generation
JP35 (Polarity)	1-2	No negation for the DTR/RTS signal
	2-3	DTR/RTS signal is negated

Default: JP24 is closed; JP3, JP4, JP5 and JP35 are open

By default, the external reset is enabled and set to immediate reset, the reset by UART is disabled.

Note:

While a reset signal is asserted the red Reset-LED D14 is lit.

During normal operation, this LED should be off!

If JP35 (Polarity) is set, JP4 and either JP3 or JP5 have to be set, too.

If the reset LED is steadily on, check the power supply input voltage and the settings for the reset-generation by UART.

3.14 Buttons SW1, SW2, SW3, SW4, SW5, SW6 (JP: 12, 14, 16, 20, 23, 24)

JP12, JP14, JP16, JP20, JP23

Five user push buttons SW1-SW5 can be connected to the microcontroller.

JP24 External reset circuit and button SW6 can be connected to the microcontroller.

Jumper	Setting	Description
JP12 (SW1)	Closed	Pin 74 (INT0) of the MCU is connected to "SW1"
	Open	No connection to the microcontroller
JP14 (SW2)	Closed	Pin 77 (INT1) of the MCU is connected to "SW2"
	Open	No connection to the microcontroller
JP16 (SW3)	Closed	Pin 53 (ATGR) of the MCU is connected to "SW3"
	Open	No connection to the microcontroller
JP20 (SW4)	Closed	Pin 2 (TIN1) of the MCU is connected to "SW4"
	Open	No connection to the microcontroller
JP23 (SW5)	Closed	Pin 4 (NMIR) of the MCU is connected to "SW5"
	Open	No connection to the microcontroller
JP24 (Reset)	Closed	RSTX is connected to the reset IC and SW6
	Open	No connection to RSTX

Default: JP12, JP14, JP16, JP20, JP23, JP24 = Closed

By default, all push-buttons as well as the reset circuit are connected to the microcontroller.

4 Programming the internal Flash memory

All Flash devices have an internal bootloader for asynchronous- as well as synchronous-Flash-programming:

- ▶ asynchronous-serial Flash-programming via X3
- ▶ synchronous-serial Flash-programming via X17

4.1 Asynchronous Mode

In order to program the Flash-ROM asynchronously, the tool “Fujitsu Flash MCU Programmer for FMC16FX” can be used. This tool is available free on the Fujitsu Micros DVD or Web Site (<http://mcu.emea.fujitsu.com/>: select ▶ Software ▶ Utilities)

The following procedure must be followed to enable Flash Programming:

1. Power off the board
2. Connect the Evaluation Board UART”A” or UART”B” to your serial PC communication port. A straight 1:1 cable connection has to be used.
3. Check the Jumper-settings according to the UART as described in chapter 3.5
4. Configure the mode:

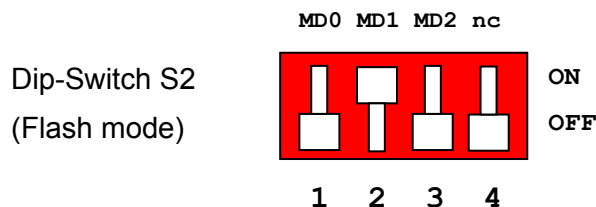

5. Power on the board

6. Check that the Reset LED is off. Otherwise change the DTR polarity (JP35) and check the power supply voltage.

Start the tool “Fujitsu Flash MCU Programmer for FMC16FX” software and follow the instructions:

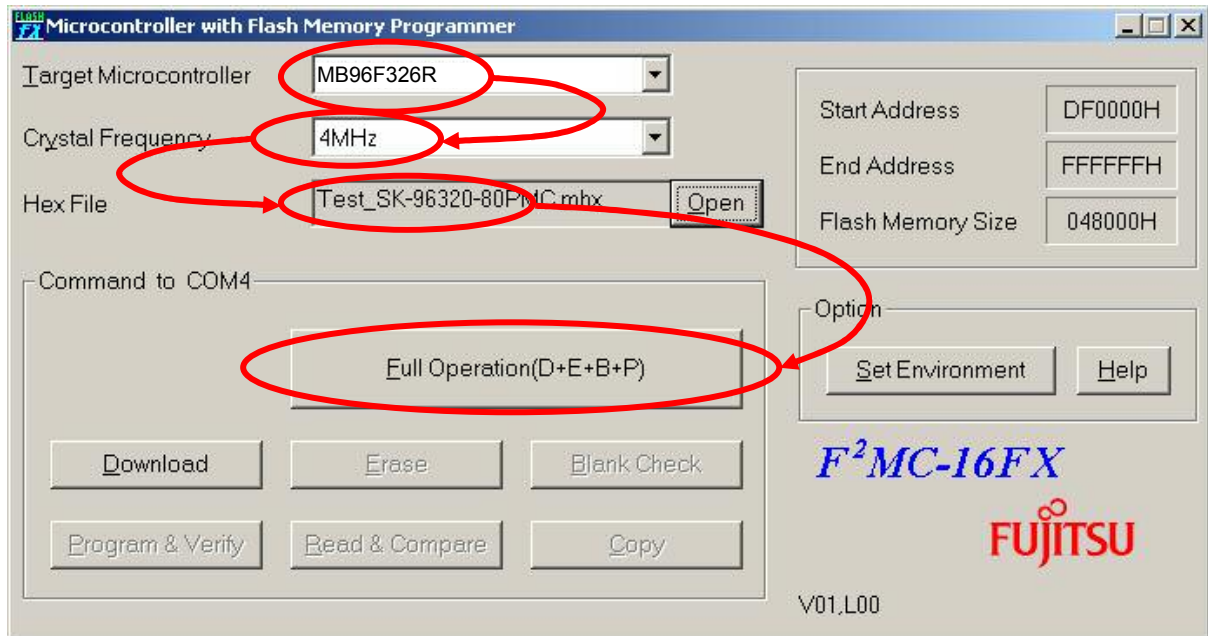

Figure 4-1: Settings for Automatic Mode

7. The software now automatically writes a flash loader to the microcontroller (“Download”), does a blank check and erases the Flash memory if necessary. After that the user application is programmed to the embedded Flash memory (“Program & Verify”).

8.

If the programming sequence has ended successfully, you will receive the output “It all ended normally completely”.

9. After programming the Flash-ROM, switch off the power supply and set back the mode according to the usage of the application, e.g.:

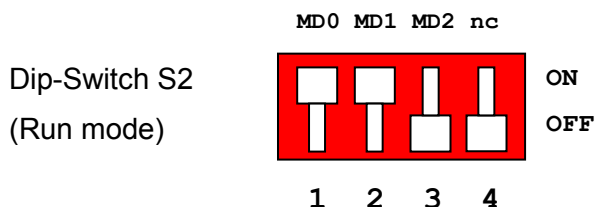

10. Power on the board. The user application is started directly.

4.2 Synchronous Mode

In order to program the Flash-ROM synchronously special third-party soft- and hardware has to be used, e.g. GALEP-4 from www.conitec.de. This tool is not available for free.

A dedicated Flash programming socket (X4) is provided on the evaluation-board for direct connection to this programmer.

X17: Flash programming socket

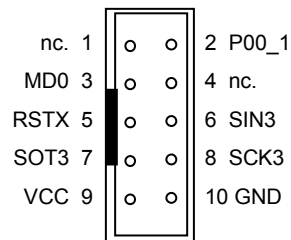
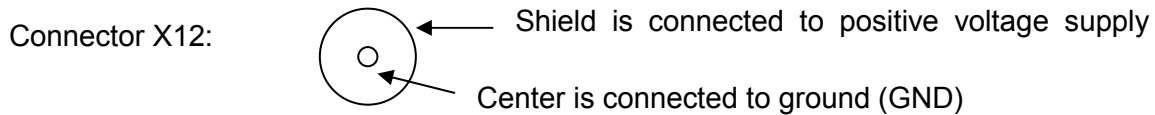

Figure 4-2: Flash Programming Socket

5 Connectors

5.1 Power connector (X12)

The following figure shows the power connection jack X12. This connector is used to connect an external unregulated DC power supply voltage (9V-12V DC) to the evaluation board.



It is recommended to use 9V DC input to minimize the power dissipation of the voltage regulators.

5.2 Edge connector (X1, X2)

All pins (except oscillator Pins) of the microcontroller are directly connected to X1 and X2 as follows:

Connector	MCU Pins
X1 (1 – 40)	1 – 40
X2 (41 – 80)	41 – 80

The odd pin numbers are located on the one side and the even pin numbers are located on the other side of the connector.

5.3 UART"A", UART"B" connector (X3, X5)

Two 9-pin D-Sub female connectors are used for the serial interface UART"A" and UART"B".

TXD is the transmit output, RXD is the receive input.

The DTR or RTS signal can be used to generate a reset.

Please use a 1:1 cable for PC-connection.

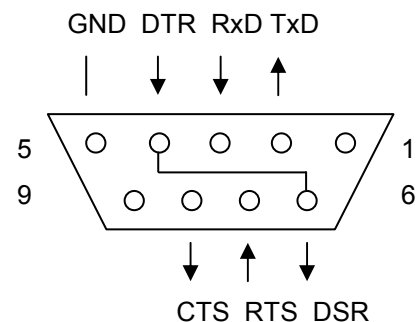

Connectors X3, X5:

5.4 LIN"A", LIN"B" Interface connector (X6, X8)

Two 9-pin D-Sub female connectors are used for the LIN communication.

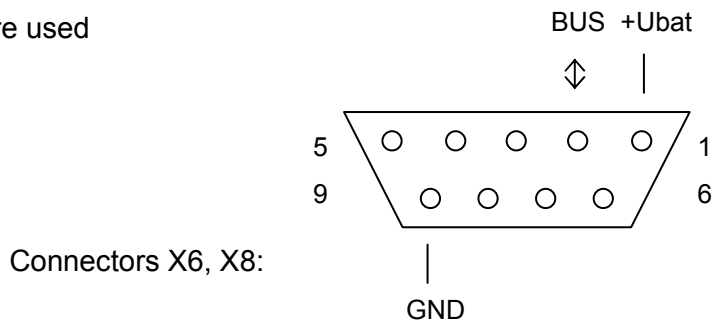

Connectors X6, X8:

5.5 CAN"A", CAN"B" Interface connector (X10, X11)

Two 9-pin D-Sub male connector are used for the CAN Bus interface.

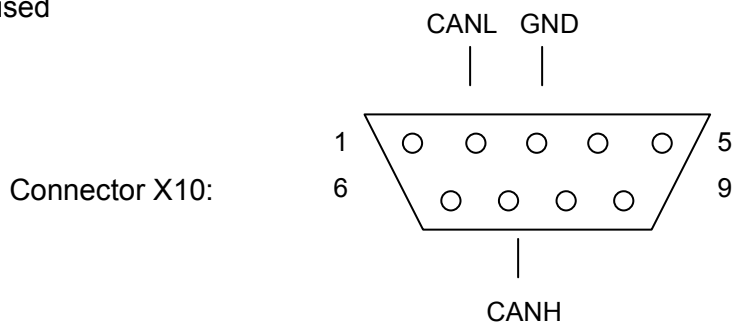

Connector X10:

5.6 USER-LEDs & optional LC-Display

Eight LEDs are supplied for user applications. In order to disconnect the LEDs from the related microcontroller port, the resistor network N1 can be removed.

Instead of the user-LEDs an alphanumeric LC-Display (optional) can be connected.

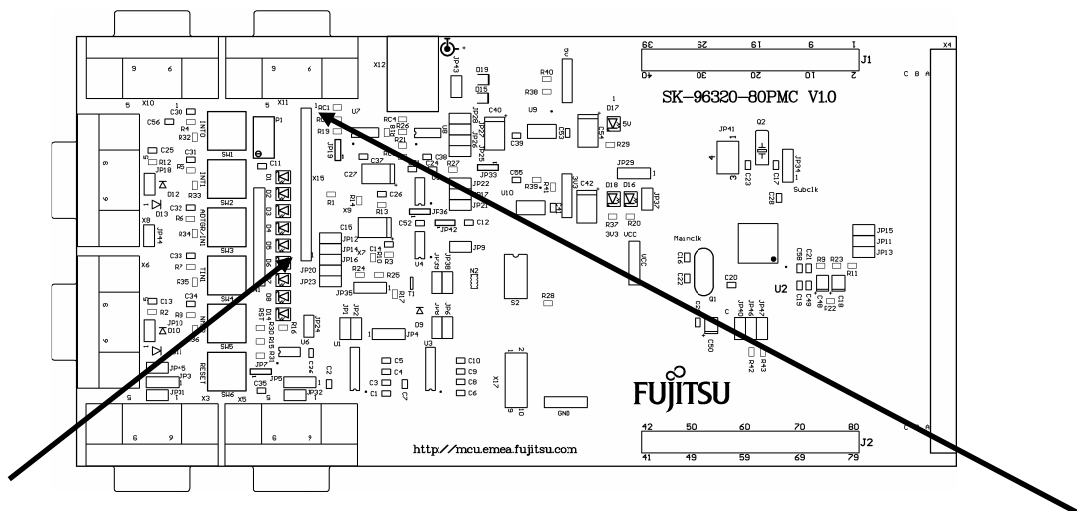

The following control signals are provided:

	14	13	12	11	10	9	8	7	6	5	4	3	2	1
LCD	D7	D6	D5	D4	-	-	-	-	E	R/W	RS	V0	VCC	GND
LED	D8	D7	D6	D5				D4	D3	D2	D1			
MCU	8	7	6	5				4	3	79	78			
Port	06_7	06_6	06_5	06_4				06_3	06_2	06_1	06_0			

5.7 VG96 connector (X4)

Connector-Pin cross-reference:

MCU	X4	Function	Evaboard	MCU	X4	Function	Evaboard
1	-	AVSS5	AVSS (JP15)	51	18B	P02_1	-
2	-	AVRH5	AVRH	52	18C	P02_2	-
3	4A	P06_2	LED D3	53	19A	P02_3	-
4	4B	P06_3	LED D4	54	19B	P02_4	-
5	4C	P06_4	LED D5	55	19C	P02_6	-
6	5A	P06_5	LED D6	56	20A	P02_7	-
7	5B	P06_6	LED D7	57	20B	RSTX	JP24
8	5C	P06_7	LED D8	58	-	X1	MP2
9	6A	P07_1	JP14 (SW2)	59	-	X0	MainClock
10	6B	P05_0	JP2 (UART A)	60	-	VSS	VSS
11	6C	P05_1	JP1 (UART A)	61	-	MCUVCC	JP37
12	7A	P05_2	-	62	-	C	JP40 (C-MCU)
13	7B	P05_3	-	63	20C	P17_2	-
14	7C	P05_4	-	64	21A	P13_5	-
15	8A	P05_5	JP23 (SW5)	65	21B	P02_5	JP16 (SW3)
16	8B	P05_6	-	66	21C	P04_4	JP46
17	8C	P05_7	-	67	22A	P04_5	JP47
18	9A	P07_0	JP12 (SW1)	68	22B	P03_3	-
19	9B	P04_2	JP26 (CAN A)	69	22C	P03_1	-
20	10C	P17_6	-	70	23A	P03_2	JP28 (CAN B)
21	10A	P04_3	JP25 (CAN A)	71	23B	P03_3	JP27 (CAN B)
22	-	MCUVCC	JP37	72	23C	P03_4	-
23	-	VSS	VSS	73	24A	P03_5	-
24	-	X0A/P04_0	JP41	74	24B	P03_6	-
25	-	X1A/P04_1	JP34	75	24C	P03_7	-
26	-	MD2	S2	76	25A	P13_6	-
27	-	MD1	S2	77	25B	P13_7	-
28	-	MD0	S2	78	25C	P06_0	LED D1
29	11A	P17_7	-	79	26A	P06_1	LED D2
30	11B	P00_0	-	80	-	AVCC5	AVCC
31	11C	P00_1	JP22 (LAN A)				
32	12A	P00_2	JP21 (LIN A)				
33	12B	P00_3	-				
34	12C	P00_4	JP39 (LIN B)				
35	13A	P00_5	JP38 (LIN B)				
36	13B	P00_6	-				
37	13C	P00_7	-				
38	14A	P09_0	-				
39	14B	P09_1	-				
40	14C	P01_0	JP20 (SW4)				
41	15A	P01_1	-				
42	15B	P01_2	JP6 (UARTB/X17)				
43	15C	P01_3	JP8 (UARTB/X17)				
44	16A	P01_4	X17				
45	16B	P01_5	-				
46	16C	P01_6	-				
47	17A	P01_7	-				
48	17B	P09_2	-				
49	17C	P09_3	-				
50	18A	P02_0	-				

6 Silk-Plot of the Board

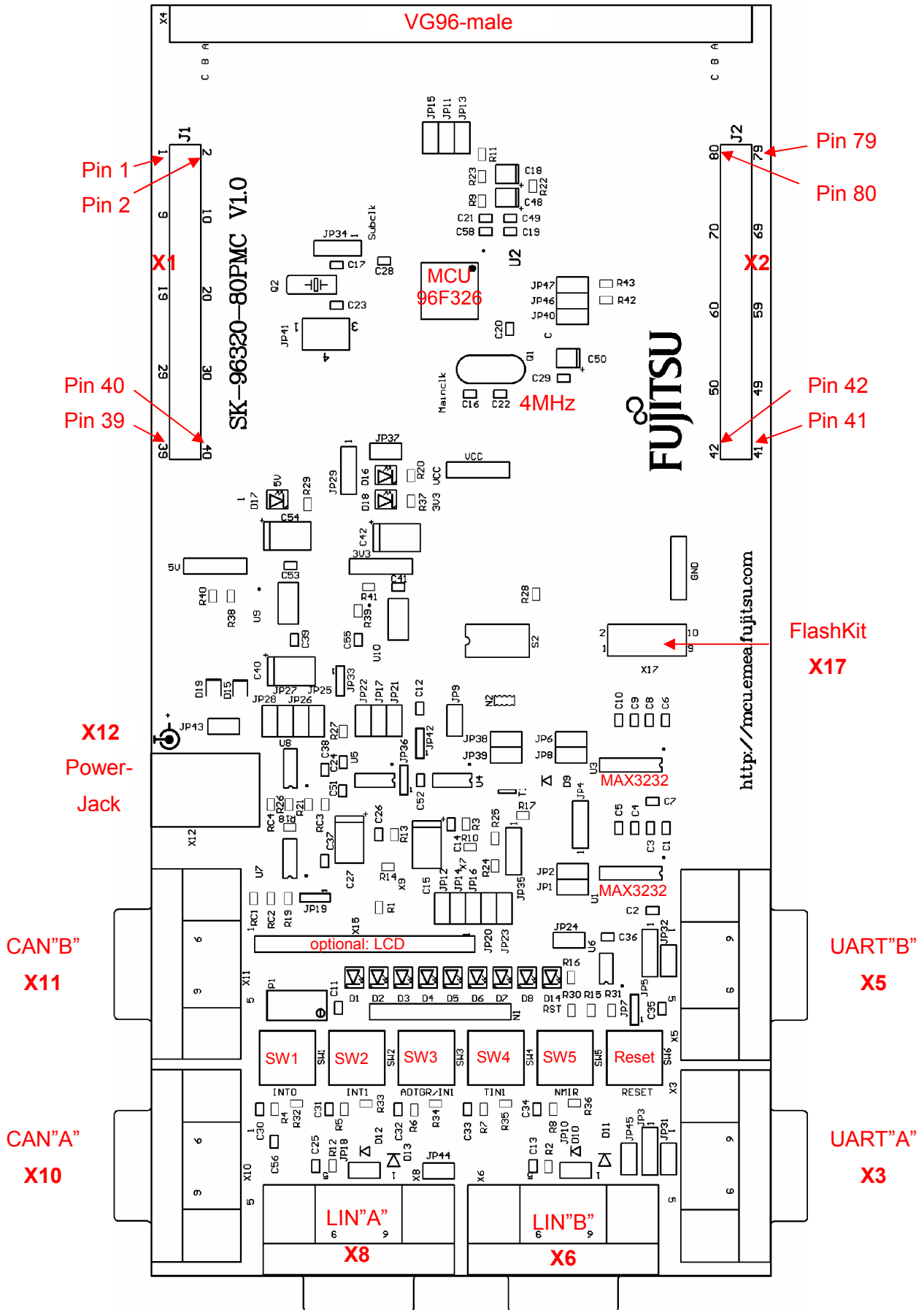

7 Revision and Error List

The following bugs have been found with the board and need to be observed when working with this tool:

Date	Revisions – Errors	Author	Rev
18.04.2007	New document	HWe/DGo	1.0
18.04.2007	EMDC Design Spec Change <ul style="list-style-type: none"> ▶ RSTx at pin 57 (former pin 55) ▶ Hand wire RST to pin 57 (required for PCB V1.0) 	HWe	1.0

8 Related Products

- ▶ SK-96320-80PMC Evaluation board for the MB96F326 MCU in FPT-80P-M21 package
- ▶ MB2198-505 Probe cable
- ▶ MB2198-01 Emulator debugger main unit
- ▶ MB2198-500 Emulation Pod / Adapter board
- ▶ NQPACK080SD-ND Socket for package FPT-80P-M21 (Tokyo Eletech Corp. <http://www.tetc.co.jp/>)
- ▶ HQPACK080SD Header for NQPACK080SD

- ▶ MB96320 Series
 - ▶ MB96V300B MB96300 Series Evaluation chip
 - ▶ MB96F326RS Flash MCU, MB96320 Series, single-clock
 - ▶ MB96F326RW Flash MCU, MB96320 Series, dual-clock

9 Information in the WWW

Information about FUJITSU MICROELECTRONICS Products can be found on the following Internet pages:

Microcontrollers (8-, 16- and 32bit), Graphics Controllers
Datasheets and Hardware Manuals, Support Tools (Hard- and Software)

<http://mcu.emea.fujitsu.com/>

Power Management Products

<http://www.fujitsu.com/emea/services/microelectronics/powerman/>

Media Products: SAW filters, acoustic resonators and VCOs

<http://www.fujitsu.com/emea/services/microelectronics/saw/>

For more information about FUJITSU MICROELECTRONICS

<http://www.fujitsu.com/emea/services/microelectronics/>

10 China-RoHS regulation

Evaluation Board 评估板

Emulation Board 仿真板

根据SJ/T11364-2006

《电子信息产品污染控制标识要求》特提供如下有关污染控制方面的信息。

The following product pollution control information is provided according to SJ/T11364-2006 *Marking for Control of Pollution caused by Electronic Information Products*.

1. 电子信息产品污染控制标志说明 Explanation of Pollution Control Label



该标志表明本产品含有超过中国标准SJ/T11363-2006

《电子信息产品中有毒有害物质的限量要求》中限量的有毒有害物质。标志中的数字为本产品的环保使用期，表明本产品在正常使用的条件下，有毒有害物质不会发生外泄或突变，用户使用本产品不会对环境造成严重污染或对其人身、财产造成严重损害的期限，单位为年。

为保证所声明的环保使用期限，应按产品手册中所规定的环境条件和方法进行正常使用，并严格遵守产品维修手册中规定的定期维修和保养要求。

产品中的消耗件和某些零部件可能有其单独的环保使用期限标志，并且其环保使用期限有可能比整个产品本身的环保使用期限短。应到期按产品维修程序更换那些消耗件和零部件，以保证所声明的整个产品的环保使用期限。

本产品在使用寿命结束时不可作为普通生活垃圾处理，应被单独收集妥善处理。

请注意：环保使用期限50年的指定不是与产品的耐久力，使用期限或任何担保要求等同的。

This symbol to be added to all EIO sold to China, indicates the product contains hazardous materials in excess of the limits established by the Chinese standard SJ/T11363-2006 *Requirements for Concentration Limits for Certain Hazardous Substances in Electronic Information Products*. The number in the symbol is the Environment-friendly Use Period (EFUP), which indicates the period, starting from the manufacturing date, during which the toxic or hazardous substances or elements contained in electronic information products will not leak or mutate under normal operating conditions so that the use of such electronic information products will not result in any severe environmental pollution, any bodily injury or damage to any assets, the unit of the period is "Year".

In order to maintain the declared EFUP, the product shall be operated normally according to the instructions and environmental conditions as defined in the product manual, and periodic maintenance schedules specified in Product Maintenance Procedures shall be followed strictly.

Consumables or certain parts may have their own label with an EFUP value less than the product. Periodic replacement of those consumables or parts to maintain the declared EFUP shall be done in accordance with the Product Maintenance Procedures.

This product must not be disposed of as unsorted municipal waste, and must be collected separately and handled properly after decommissioning.

Please note: The designation of 10 years EFUP is not to be equated with the durability, use-duration or any warranty-claims of the product.

产品中有毒有害物质或元素的名称及含量

Table of hazardous substances name and concentration

部件名称 Component Name	有毒有害物质或元素 Hazardous substances name					
	铅 (Pb)	汞 (Hg)	镉 (Cd)	六价铬 (Cr (VI))	多溴联苯 (PBB)	多溴二苯醚 (PBDE)
SK-96320-80PMC	x	o	o	o	o	o

O: 表示该有毒有害物质在该部件所有均质材料中的含量均在SJ/T11363-2006 标准规定的限量要求以下

X: 表示该有毒有害物质至少在该部件的某一均质材料中的含量超出SJ/T11363-2006 标准规定的限量要求

- 此表所列数据为发布时所能获得的最佳信息
- 由于缺少经济上或技术上合理可行的替代物质或方案，此医疗设备运用以上一些有毒有害物质来实现设备的预期临床功能，或给人员或环境提供更好的保护效果。

O: Indicates that this toxic or hazardous substance contained in all of the homogeneous materials for this part is below the limit requirement in SJ/T11363-2006.

X: Indicates that this toxic or hazardous substance contained in at least one of the homogeneous materials used for this part is above the limit requirement in SJ/T11363-2006.

- Data listed in the table represents best information available at the time of publication

11 Recycling

Gültig für EU-Länder:

Gemäß der Europäischen WEEE-Richtlinie und deren Umsetzung in landesspezifische Gesetze nehmen wir dieses Gerät wieder zurück.

Zur Entsorgung schicken Sie das Gerät bitte an die folgende Adresse:

Fujitsu Microelectronics Europe GmbH
Warehouse/Disposal
Monzastraße 4a
63225 Langen

Valid for European Union Countries:

According to the European WEEE-Directive and its implementation into national laws we take this device back.

For disposal please send the device to the following address:

Fujitsu Microelectronics Europe GmbH
Warehouse/Disposal
Monzastraße 4a
63225 Langen