

RSF50 Series

Compact internal fitting vertical mounting floatswitch



- Compact design
- Reliable reed switch contacts
- Available in Nylon, Polypropylene or PPS
- WRAS Approval
- UL Approval (File no E171218)

The RSF50 series are compact vertically mounted devices with a single switch point. Mounting is either from the top or bottom of the tank from the inside, so requires access to the inside of the tank.

Typical applications include vending machines, printing systems and chemical dosing equipment.

They are manufactured in a variety of materials, with a choice of gasket materials, to suit most commonly used liquids.

The switch action may be reversed by removing the float, inverting it, and then refitting to the stem.

All types are available with 1/8" NPT tapered thread.

Technical Specification	RSF58	RSF53	RSF54	RSF56
Material	Polypropylene UL Approved	Nylon	Polypropylene WRAS Approved	Polyphenylene Sulphide (PPS)
Colour	White	Black	Opaque	Grey
Temp. Range °C	-20 / +100	-20 / +75	-20 / +100	-10 / +120*
°F	-4 / +212	-4 / +167	-4 / +212	+14 / +248*
Min. Fluid S.G.	0.65	0.8	0.65	0.85
Must Close Level (S.G.=1)	15mm	11.5mm	15mm	9.5mm
Must Open Level (S.G.=1)	26mm	22.5mm	26mm	20.5mm

*Maximum temperature requires ETFE cable to be specified.

Electrical Specification	25W (Y Switch)	100W (H Switch)
Contact Form	N/O (N/C)	N/O (N/C)
Switching Power Max. VA	25VA	100VA
Switching Voltage AC Max.	240V	300V
Switching Voltage DC Max.	120V	300V
Switching Current Max. A	0.6A	1A

All ratings are for resistive load only.

Standard Parts	Material	Leadouts	Gaskets
RSF53H/Y100RF	Nylon	1.0m PVC 16/0.2 UL approved	Nitrile
RSF54H/Y100RF	Polypropylene	1.0m PVC 16/0.2 UL approved	Nitrile
RSF56H/Y100RF	PPS	1.0m PVC 16/0.2 UL approved	Nitrile
RSF58H/Y100RF	Polypropylene (UL)	1.0m PVC 16/0.2 UL approved	Nitrile

Custom versions can be made for particular applications. Please contact Cynergy3 with your requirements.

Mechanical Dimensions

All dimensions are in millimeters (inches)

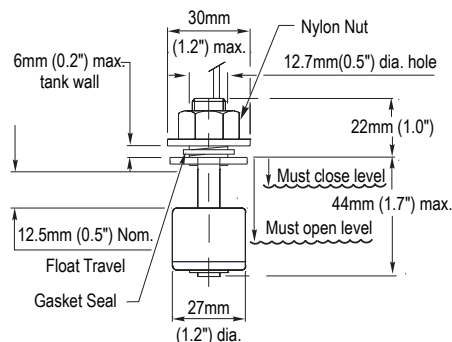

Thread sizes
RSF53/4/6 M12x1.75 Thread
Also available with 1/8" NPT Thread

Note: Float Chamber may be inverted for alternative switch action.

USA
Cynergy3 Components Corporation
11125 Knott Avenue, Suite D,
Cypress, CA, 90630.
Phone (866) 258-5057
Email: sales@cynergy3.com

EUROPE - UK
Cynergy3 Components Ltd.
7 Cobham Road
Ferndown Industrial Estate
Wimborne, Dorset BH21 7PE
Telephone +44 (0) 1202 897969
Fax +44 (0) 1202 891918
Email: sales@cynergy3.com

ISO 9001 CERTIFIED

Competitive part number cross-reference available at: www.cynergy3.com