



LUXEON Rebel
Automotive Specification

*Optimized solutions for
automotive applications*

Technical Datasheet DS58

L U X E N[®]
never before possible



LUXEON[®] Rebel

Automotive Specification

Introduction

Automotive Specification LUXEON[®] Rebel LEDs are specifically designed and tested to meet and exceed expectations for reliability, performance and lifetime in all vehicle applications. Philips Lumileds automotive color binning structure meets both SAE and ECE color specifications and provides finer granularity than existing systems. PPAP documentation is available upon request. Automotive Specification LUXEON Rebel LEDs are superior LED products for:

- Daytime Running Lights (DRL)
- Turn Lamps
- Stop/Tail Lamps
- Position Lamps
- Backup Lamps
- Side Marker Lamps
- Rear Fog Lamps
- Interior Lamps.

PHILIPS
LUMILEDS

Table of Contents

Product Nomenclature.....	3
Average Lumen Maintenance Characteristics	3
Environmental Compliance.....	3
Flux Characteristics.....	4
Optical Characteristics.....	5
Electrical Characteristics.....	6
Absolute Maximum Ratings	7
Automotive White Short-Term Maximum Rating Estimated Lifetime.....	8
Automotive Red-Orange and Amber Short-Term Maximum Rating Estimated Lifetime.....	8
JEDEC Moisture Sensitivity.....	9
Reflow Soldering Characteristics	10
Mechanical Dimensions	11
Pad Configuration	12
Solder Pad Design.....	12
Wavelength Characteristics.....	13
Typical Light Output Characteristics over Temperature.....	14
Typical Forward Current Characteristics.....	15
Typical Relative Luminous Flux	16
Current Derating Curves.....	17
Typical Radiation Patterns.....	19
Emitter Pocket Tape Packaging.....	21
Emitter Reel Packaging	22
Automotive Product Binning and Labeling.....	23

Product Nomenclature

LUXEON Rebel is tested and binned at 350 mA.

The part number designation is explained as follows:

L X M A - A B C D - E F G H

Where:

- A — designates radiation pattern (value P for Lambertian)
- B — designates color variant (W for automotive white)
- C — designates color variant (0 for automotive white)
- D — designates test current (value I for 350 mA)
- E — reserved for future product offerings
- FGH — minimum luminous flux (lm) performance

Products tested and binned at 350 mA follow the part numbering scheme:

L X M A - P x 0 I - x x x x

Average Lumen Maintenance Characteristics

Lifetime for solid-state lighting devices (LEDs) is typically defined in terms of lumen maintenance—the percentage of initial light output remaining after a specified period of time.

Philips Lumileds projects that LUXEON Rebel Automotive White products will deliver, on average, 70% lumen maintenance at 50,000 hours of operation at a forward current of 350 mA. This projection is based on constant current operation with junction temperature maintained at or below 135°C.

Philips Lumileds projects that red-orange and amber LUXEON Rebel products will deliver, on average, 70% lumen maintenance at 30,000 hours of operation at a forward current of 350 mA. This projection is based on constant current operation with junction temperature maintained at or below 125°C.

This performance is based on independent test data, Philips Lumileds historical data from tests run on similar material systems, and internal LUXEON reliability testing. Observation of design limits included in this data sheet is required in order to achieve this projected lumen maintenance.

Environmental Compliance

Philips Lumileds is committed to providing environmentally friendly products to the solid-state lighting market. The LUXEON Rebel is compliant to the European Union directives on the restriction of hazardous substances in electronic equipment, namely the REACH, ELV, and RoHS directives. Philips Lumileds will not intentionally add the following restricted materials to the LUXEON Rebel: lead, mercury, cadmium, hexavalent chromium, polybrominated biphenyls (PBB) or polybrominated diphenyl ethers (PBDE).

Flux Characteristics

Flux Characteristics for LUXEON Rebel Junction Temperature, $T_j = 25^\circ\text{C}$ [4]

Table I.

Performance at Test Current				Typical Performance at Indicated Current	
Color	Part Number	Minimum Luminous Flux (lm) Φ_v [1] [3]	Test Current (mA)	Typical Luminous Flux (lm) Φ_v [2] [3]	Drive Current (mA)
Automotive White	LXMA-PW01-0090	90	350	165	700
	LXMA-PW01-0100	100	350	180	700
Red-Orange	LXMA-PH01-0040	40	350	60	500
	LXMA-PH01-0050	50	350	75	500
Amber	LXMA-PL01-0023	23.5	350	40	500
	LXMA-PL01-0030	30	350	55	500

Notes for Table I:

1. Minimum luminous flux performance guaranteed within published operating conditions. Philips Lumileds maintains a tolerance of $\pm 6.5\%$ on flux measurements.
2. Typical luminous flux or radiometric power performance when device is operated within published operating conditions.
3. LUXEON Rebel products with even higher luminous flux and radiometric power levels will become available in the future. Please consult Philips Lumileds or Future Electronics for more information.
4. Junction Temperature is estimated based on instant measurement at thermal pad temperature of 25°C .

Optical Characteristics

Lambertian LUXEON Rebel at Test Current ^[1] Junction Temperature, $T_j = 25^\circ\text{C}$ ^[10]

Table 2.

Color	Color Temperature ^{[2],[3]} CCT			Typical Spectral Half-width ^[5] (nm) $\Delta\lambda_{1/2}$	Typical Temperature Coefficient of Dominant Wavelength (nm/°C) $\Delta\lambda_D / \Delta T_j$	Typical Total Included Angle ^[6] (degrees) $\theta_{0.90V}$	Typical Viewing Angle ^[7] (degrees) $2\theta_{1/2}$
	Min.	Typ.	Max.				
Automotive White ^[8]	3800 K	5500 K	6300 K	—	—	160	120
Red-Orange ^[9]	613.5 nm	617.0 nm	620.5 nm	20	0.06	160	120
Amber ^[9]	587.0 nm	589.0 nm	592.0 nm	14	0.09	160	120

Notes for Table 2:

- LUXEON Rebel is tested and binned at 350 mA.
- Dominant wavelength is derived from the CIE 1931 Chromaticity diagram and represents the perceived color. Philips Lumileds maintains a tolerance of ± 0.5 nm for dominant wavelength measurements.
- CCT $\pm 5\%$ tester tolerance.
- CRI (Color Rendering Index) for white product types is 70 typical.
- Spectral width at $1/2$ of the peak intensity.
- Total angle at which 90% of total luminous flux is captured.
- Viewing angle is the off axis angle from lamp centerline where the luminous intensity is $1/2$ of the peak value.
- All white products are built with Indium Gallium Nitride (InGaN).
- All red-orange and amber products are built with Aluminum Indium Gallium Phosphide (AlInGaP).
- Junction Temperature is estimated based on instant measurement at thermal pad temperature of 25°C .

Electrical Characteristics

Electrical Characteristics at 350 mA for LUXEON Rebel, Part Numbers LXMA-Px01-0xxx, Junction Temperature = 25°C

Table 3.

Color	Forward Voltage V_f ^[1] (V)			Typical Dynamic Resistance ^[2] (Ω) R_D	Typical Temperature Coefficient of Forward Voltage ^[3] (mV/°C) $\Delta V_F / \Delta T_J$	Typical Thermal Resistance Junction to Thermal Pad (°C/W) $R\theta_{J-C}$
	Min.	Typ.	Max.			
Automotive White	2.55	3.05	3.75	0.3	-3.0	10
Red-Orange	2.31	2.9	3.51	1.5	-3.0	12
Amber	2.31	2.9	3.51	1.3	-2.5	12

Notes for Table 3:

1. Philips Lumileds maintains a tolerance of $\pm 0.06V$ on forward voltage measurements.
2. Dynamic resistance is the inverse of the slope in linear forward voltage model for LEDs. See figure 8.
3. Measured between $25^\circ C = T_J = 110^\circ C$ at $I_f = 350$ mA.

Typical Electrical Characteristics at 700 mA for LUXEON Rebel, Part Numbers LXMA-Px01-0xxx, Junction Temperature = 25°C

Table 4.

Color	Typical Forward Voltage V_f (V)
Automotive-White	3.25
Red-Orange	3.25 at 500 mA
Amber	3.25 at 500 mA

Notes for Table 4:

1. Philips Lumileds maintains a tolerance of $\pm 0.06V$ on forward voltage measurements.
2. Dynamic resistance is the inverse of the slope in linear forward voltage model for LEDs. See figure 8.
3. Measured between $25^\circ C = T_J = 110^\circ C$ at $I_f = 700$ mA.

Absolute Maximum Ratings

Table 5.

Parameter	Automotive White	Red-Orange / Amber
DC Forward Current (mA)	700	500
Peak Pulsed Forward Current (mA)	1000	700
Average Forward Current (mA)	700	500
ESD Sensitivity ^[5]	8kV HBM, 400V MM	8kV HBM, 400V MM
LED Junction Temperature ^[1]	135°C	125°C
Operating Case Temperature at 350 mA	-40°C - 120°C	-40°C - 110°C
Storage Temperature	-40°C - 135°C	-40°C - 135°C
Soldering Temperature	JEDEC 020c 260°C	JEDEC 020c 260°C
Allowable Reflow Cycles	3	3
Autoclave Conditions	121°C at 2 ATM	
	100% Relative Humidity for 96 Hours Maximum	
Reverse Voltage (Vr)	See Note 2	See Note 2
Automotive White LED Junction Temp @ 700 mA ^[3]	115°C	
Automotive Short-Term Maximum LED Junction Temp ^[4]	150°C	135°C

Notes for Table 5:

1. Proper current derating must be observed to maintain junction temperature below the maximum. Product driven at 350 mA.
2. LUXEON Rebel LEDs are not designed to be driven in reverse bias.
3. LUXEON Rebel Automotive White LEDs driven at 700 mA need to maintain LED junction temperature below 115°C.
4. LUXEON Rebel Automotive LEDs driven at short-term maximum LED junction temperature will have limited lifetime.
See BnL tables in next section.
5. Measured using human body model and machine model (per AEC-Q101C).

Automotive White Short-Term Maximum Rating Estimated Lifetime ^[1]

Operating Condition	B50L70	B3L70
200 mA, $T_c \sim 125^\circ\text{C}$, $T_j \sim 135^\circ\text{C}$	50000 hrs	18000
200 mA, $T_c \sim 135^\circ\text{C}$, $T_j \sim 145^\circ\text{C}$	50000	10000
250 mA, $T_c \sim 135^\circ\text{C}$, $T_j \sim 150^\circ\text{C}$	50000	7500
350 mA, $T_c \sim 120^\circ\text{C}$, $T_j \sim 135^\circ\text{C}$	50000	10000
350 mA, $T_c \sim 135^\circ\text{C}$, $T_j \sim 150^\circ\text{C}$	31000	5900
500 mA, $T_c \sim 130^\circ\text{C}$, $T_j \sim 150^\circ\text{C}$	23000	4400
700 mA, $T_c \sim 120^\circ\text{C}$, $T_j \sim 150^\circ\text{C}$	17000	3300

Note for Table 6:

- I. Lifetime shown are estimation of expected lifetimes (Bxx, Lyy) computed as 90% lower confidence limit of the LUXEON Rebel Automotive White product as a function of drive current and junction/case temperature. The lifetime estimates in above table reflect only statistical figures based on calculations of technical data and are subjected to change. They do not automatically represent the actual performance of each LED as the LEDs are produced with semiconductor technology that is subject to process variation.

Automotive Red-Orange and Amber Short-Term Maximum Rating Estimated Lifetime ^[1]

Operating Condition	B50L70	B3L70
200 mA, $T_c \sim 115^\circ\text{C}$, $T_j \sim 125^\circ\text{C}$	50000 hrs	14000
200 mA, $T_c \sim 125^\circ\text{C}$, $T_j \sim 130^\circ\text{C}$	50000	10000
250 mA, $T_c \sim 115^\circ\text{C}$, $T_j \sim 135^\circ\text{C}$	50000	6000
350 mA, $T_c \sim 100^\circ\text{C}$, $T_j \sim 125^\circ\text{C}$	30000	4000
350 mA, $T_c \sim 110^\circ\text{C}$, $T_j \sim 135^\circ\text{C}$	21000	2500
500 mA, $T_c \sim 100^\circ\text{C}$, $T_j \sim 135^\circ\text{C}$	11000	1200

Note for Table 7:

- I. Lifetime shown are estimation of expected lifetimes (Bxx, Lyy) computed as 90% lower confidence limit of the LUXEON Rebel Automotive Red-Orange and Amber product as a function of drive current and junction/case temperature. The lifetime estimates in above table reflect only statistical figures based on calculations of technical data and are subjected to change. They do not automatically represent the actual performance of each LED as the LEDs are produced with semiconductor technology that is subject to process variation.

JEDEC Moisture Sensitivity

Table 8.

Level	Floor Life		Soak Requirements	
	Time	Conditions	Standard	
			Time	Conditions
I	unlimited	≤ 30°C / 85% RH	168h + 5 / -0	85°C / 85% RH

Reflow Soldering Characteristics

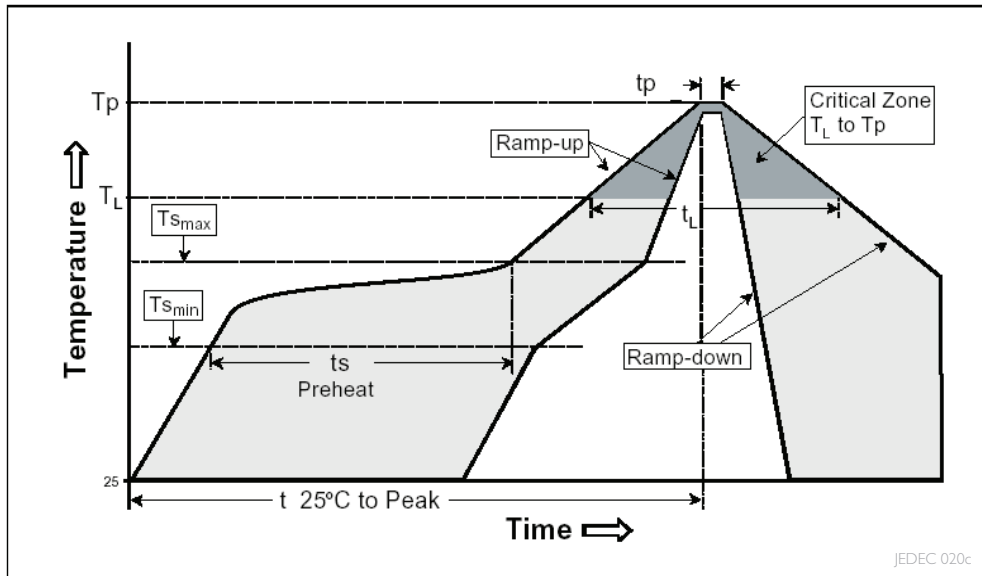

Temperature Profile for Table 9.

Table 9.

Profile Feature	Lead Free Assembly
Average Ramp-Up Rate ($T_{s_{max}}$ to T_p)	3°C / second max
Preheat Temperature Min ($T_{s_{min}}$)	150°C
Preheat Temperature Max ($T_{s_{max}}$)	200°C
Preheat Time ($t_{s_{min}}$ to $t_{s_{max}}$)	60 - 180 seconds
Temperature (T_L)	217°C
Time Maintained Above Temperature T_L (t_L)	60 - 150 seconds
Peak / Classification Temperature (T_p)	260°C
Time Within 5°C of Actual Peak Temperature (T_p)	20 - 40 seconds
Ramp - Down Rate	6°C / second max
Time 25°C to Peak Temperature	8 minutes max

Notes for Table 9:

- I. All temperatures refer to the application Printed Circuit Board (PCB), measured on the surface adjacent to the package body.

Mechanical Dimensions

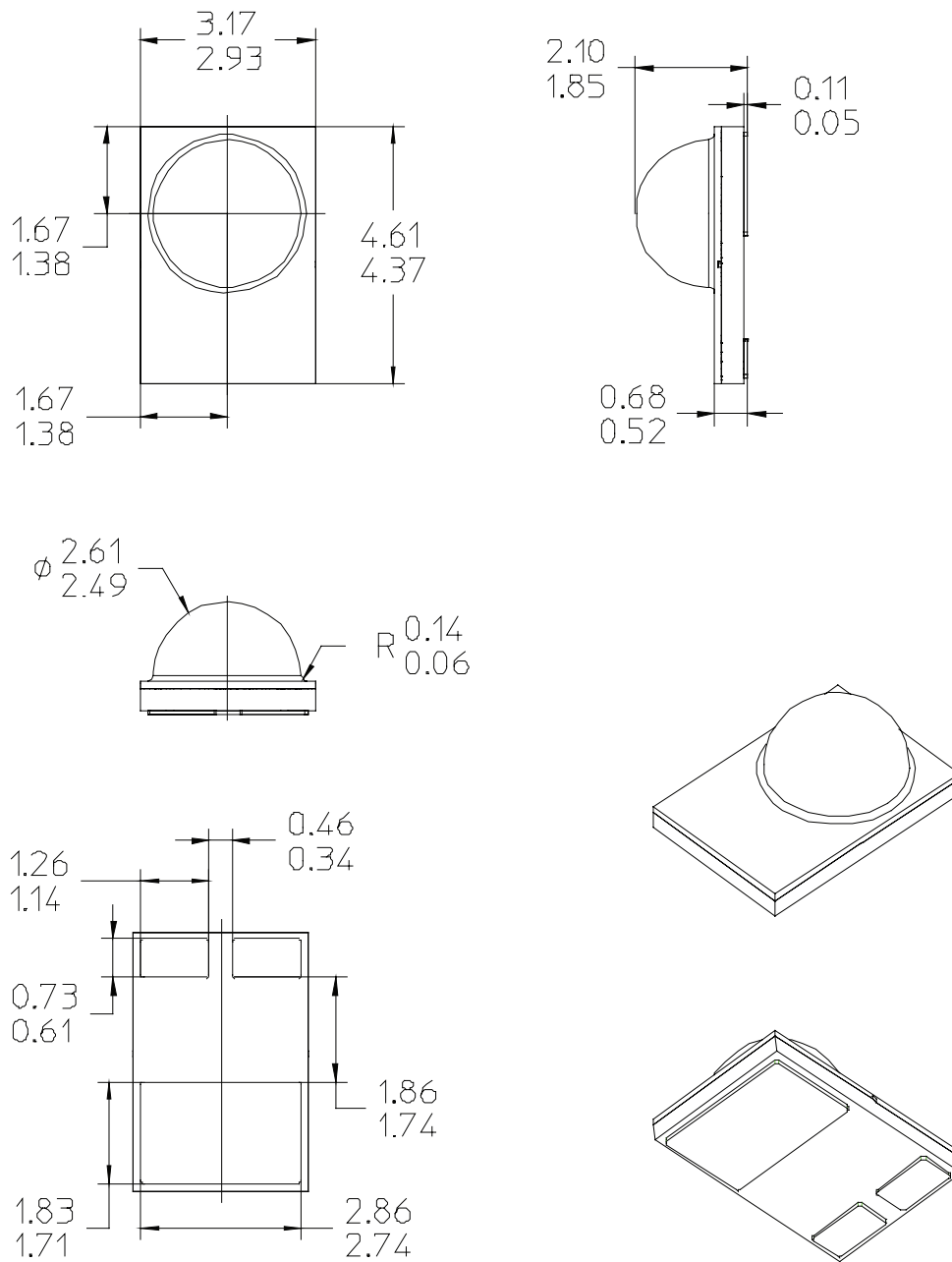

Figure I. Package Outline Drawing.

Notes for Figure I:

1. Do not handle the device by the lens—care must be taken to avoid damage to the lens or the interior of the device that can be damaged by excessive force to the lens.
2. Drawings not to scale.
3. All dimensions are in millimeters.
4. The Thermal Pad is electrically isolated from the Anode and Cathode contact pads.

Pad Configuration

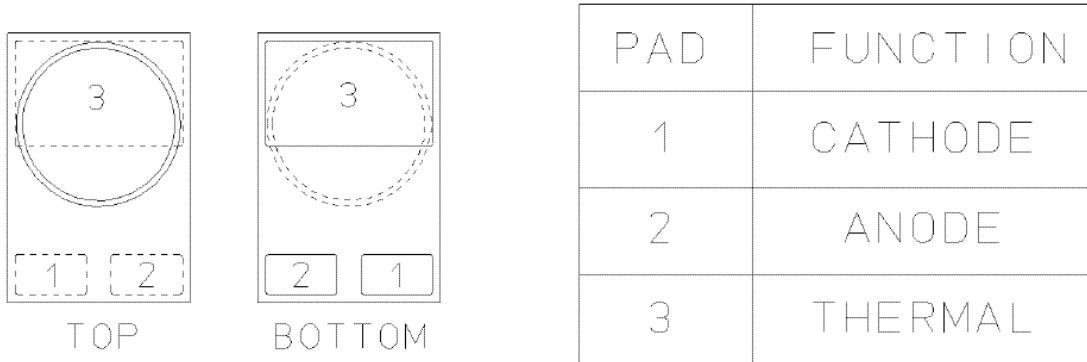

Figure 2. Pad Configuration.

Note for Figure 2:

1. The Thermal Pad is electrically isolated from the Anode and Cathode contact pads.

Solder Pad Design

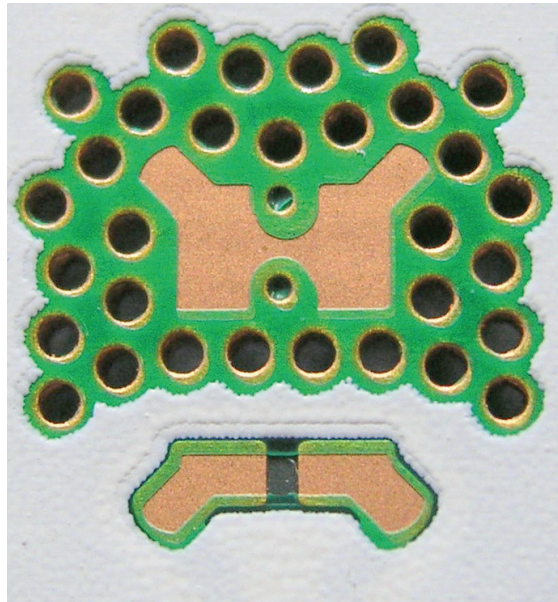

Figure 3. Solder Pad Layout.

Note for Figure 3:

The photograph shows the recommended LUXEON Rebel layout on Printed Circuit Board (PCB). This design easily achieves a thermal resistance of 7 K/W.

Application Brief AB32 provides extensive details for this layout. In addition, the .dwg files are available at www.philipslumileds.com.

Wavelength Characteristics

Red-Orange and Amber at Test Current Thermal Pad Temperature = 25°C

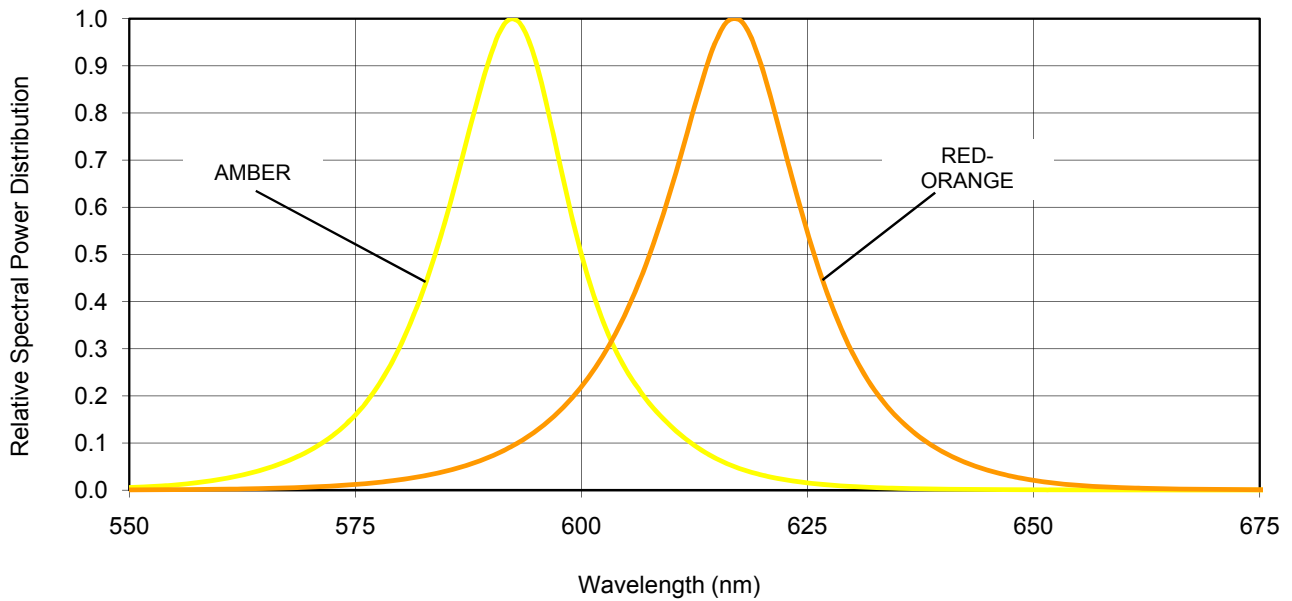

Figure 4. Relative Intensity vs. Wavelength.

Automotive White, Thermal Pad Temperature = 25°C

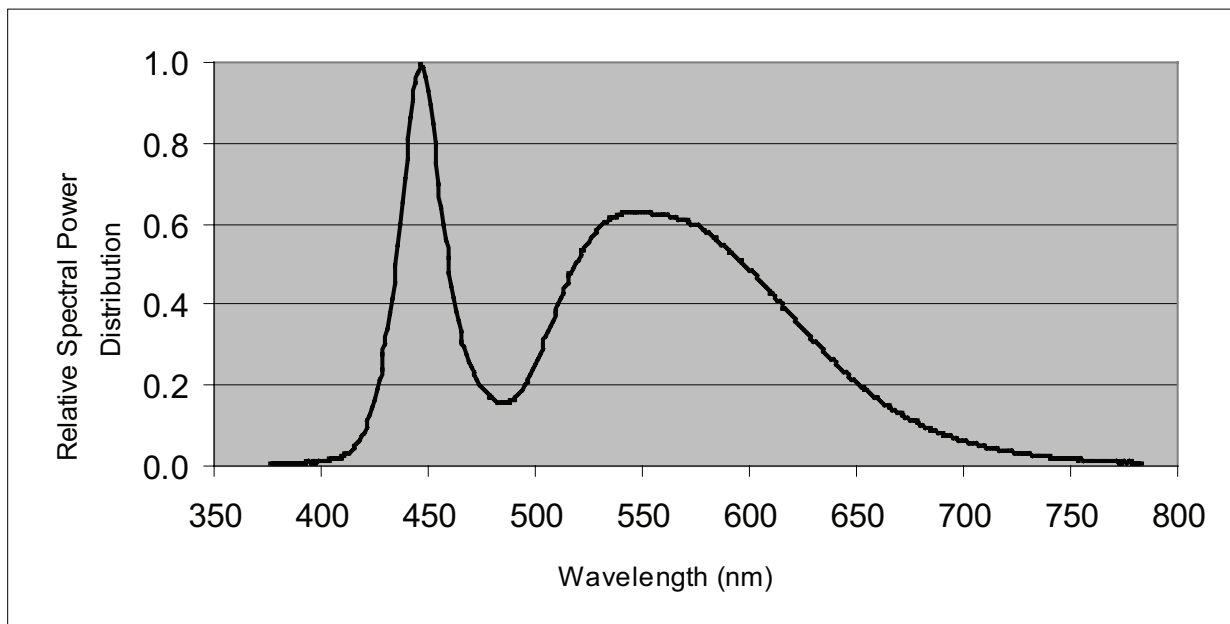

Figure 5. White Color Spectrum of Typical CCT Part, Integrated Measurement.

Typical Light Output Characteristics over Temperature

Automotive White at Test Current

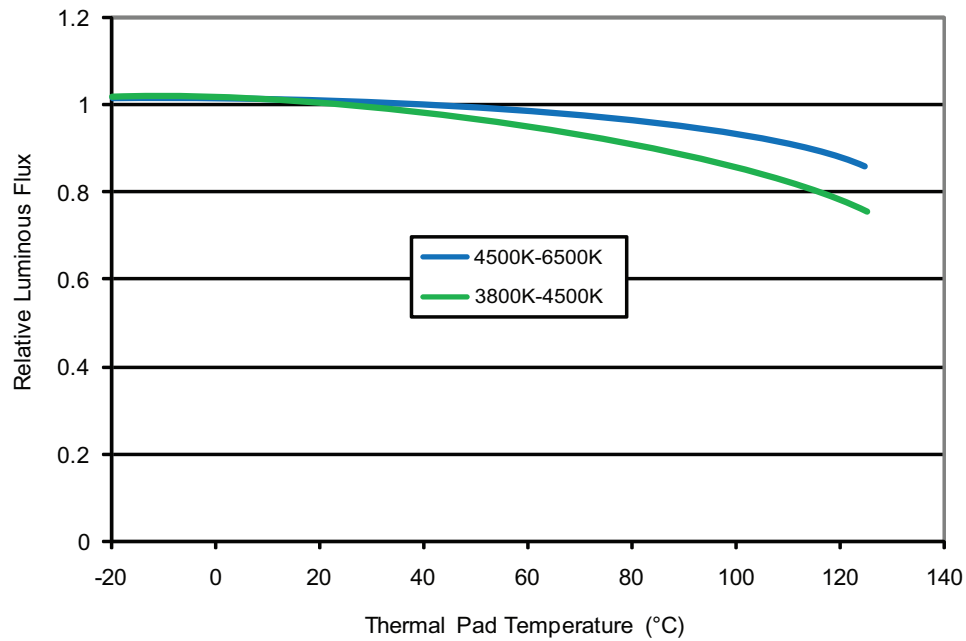

Figure 6. Relative Light Output vs. Thermal Pad Temperature.

Red-Orange and Amber at Test Current

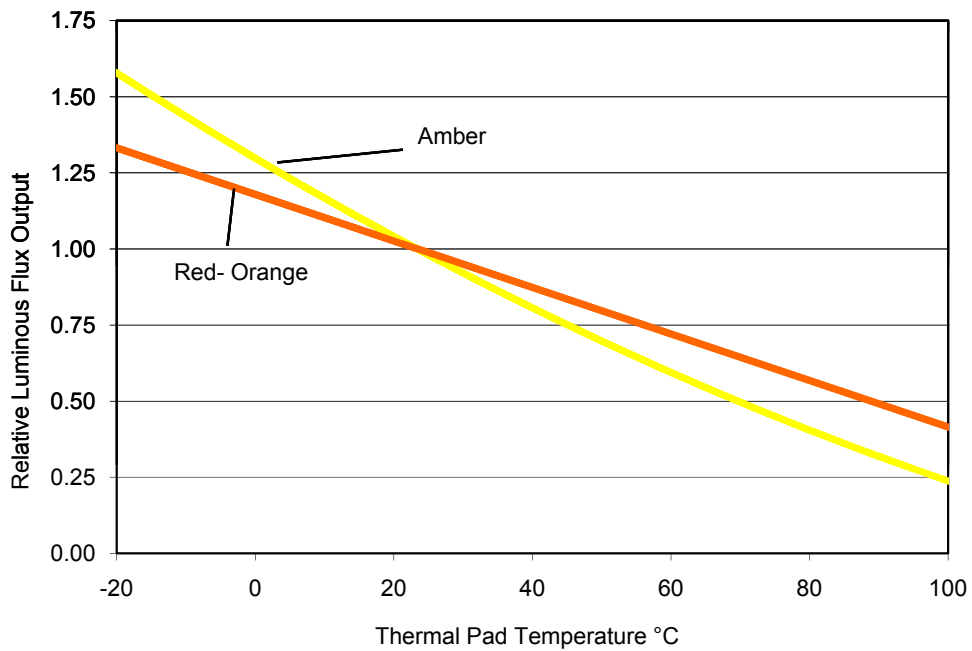

Figure 7. Relative Light Output vs. Junction Temperature for Red-Orange and Amber.

Typical Forward Current Characteristics

Automotive White, Thermal Pad Temperature = 25°C

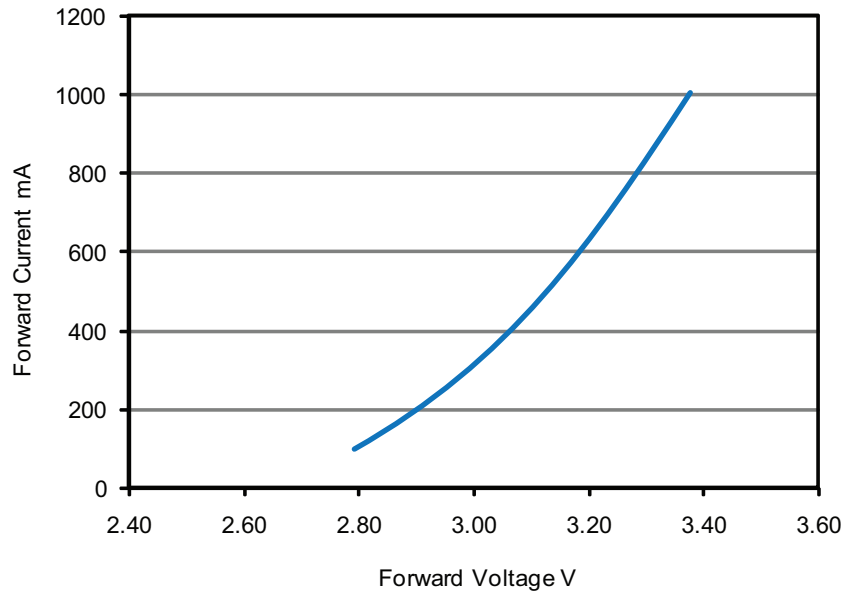

Figure 8. Forward Current vs. Forward Voltage for Automotive White.

Red-Orange and Amber, Thermal Pad Temperature = 25°C

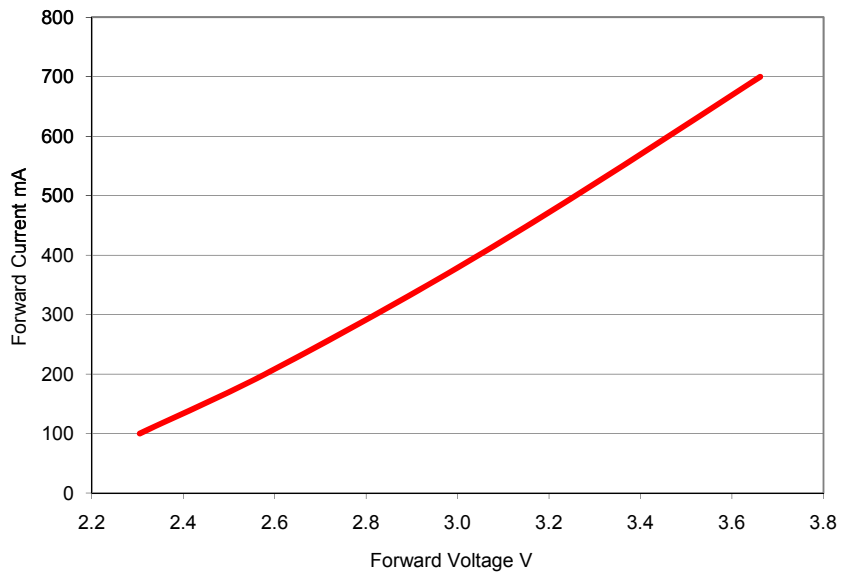

Figure 9. Forward Current vs. Forward Voltage for Red-Orange and Amber.

Notes for Figures 8 & 9:

Driving these high power devices at currents less than the test conditions (350 mA and 700 mA) may produce unpredictable results and may be subject to variation in performance. Pulse width modulation (PWM) is recommended for dimming effects.

Typical Relative Luminous Flux

Relative Luminous Flux vs. Forward Current for Automotive White, Thermal Pad Temperature = 25°C

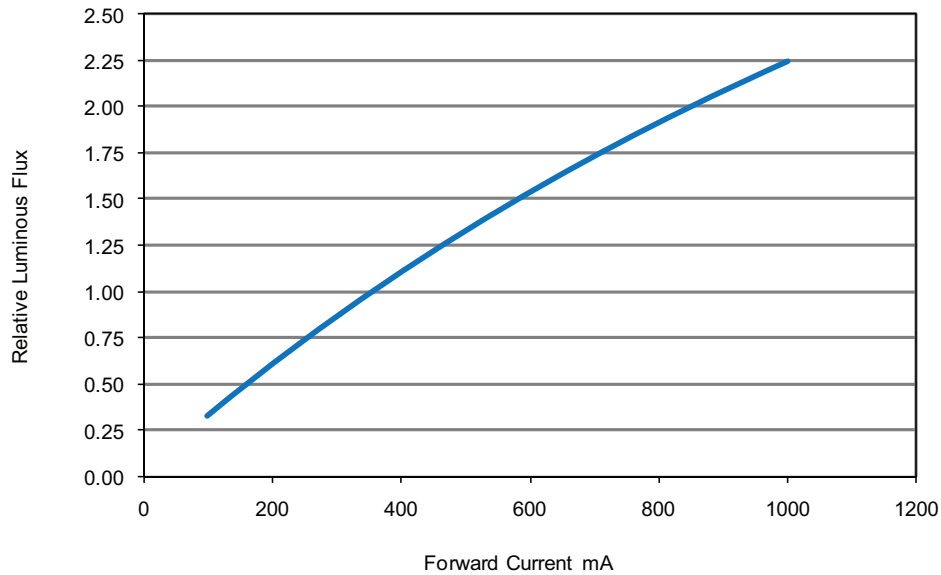

Figure 10. Relative Luminous Flux or Radiometric Power vs. Forward Current for White at Thermal Pad = 25°C Maintained, Normalized to a Test Current of 350 mA.

Typical Relative Luminous Flux vs. Forward Current for Red-Orange and Amber, Thermal Pad Temperature = 25°C

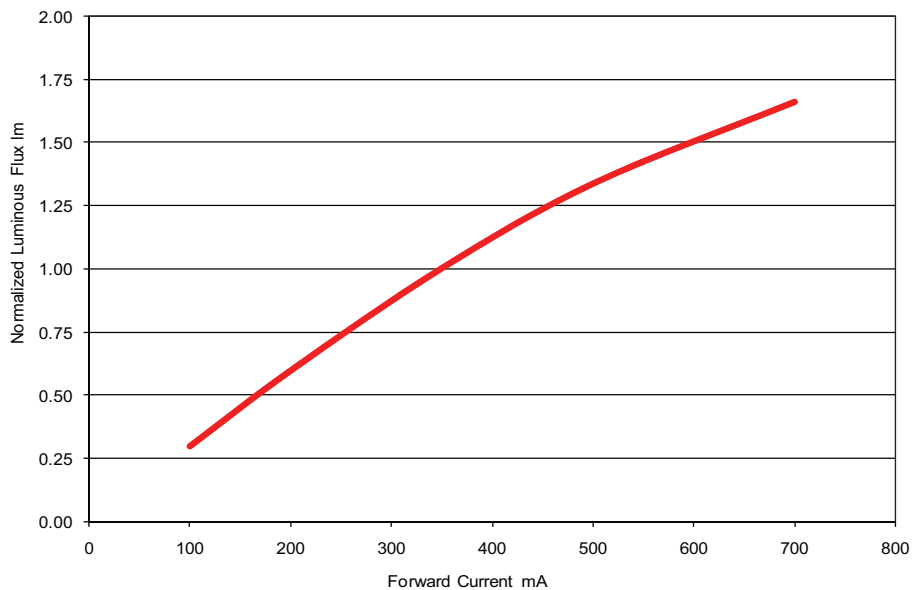

Figure 11. Relative Luminous Flux or Radiometric Power vs. Forward Current for Red-Orange and Amber at $T_j = 25^\circ\text{C}$ Maintained, Normalized to a Test Current of 350 mA.

Current Derating Curves

Current Derating Curve for 350 mA Drive Current Automotive White

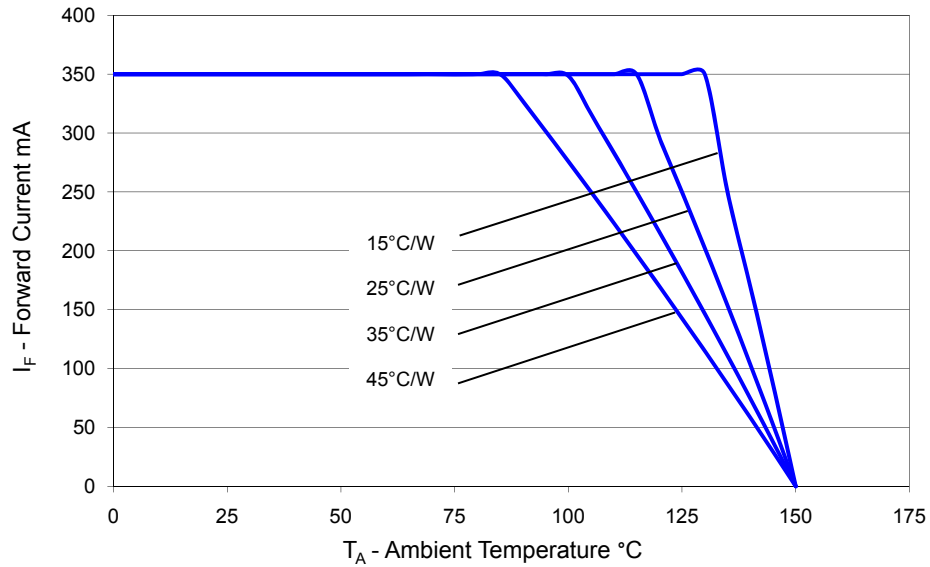

Figure 12. Maximum Forward Current vs. Ambient Temperature, Based on $T_{JMAX} = 150^{\circ}\text{C}$.

Current Derating Curve for 350 mA Drive Current Red-Orange and Amber

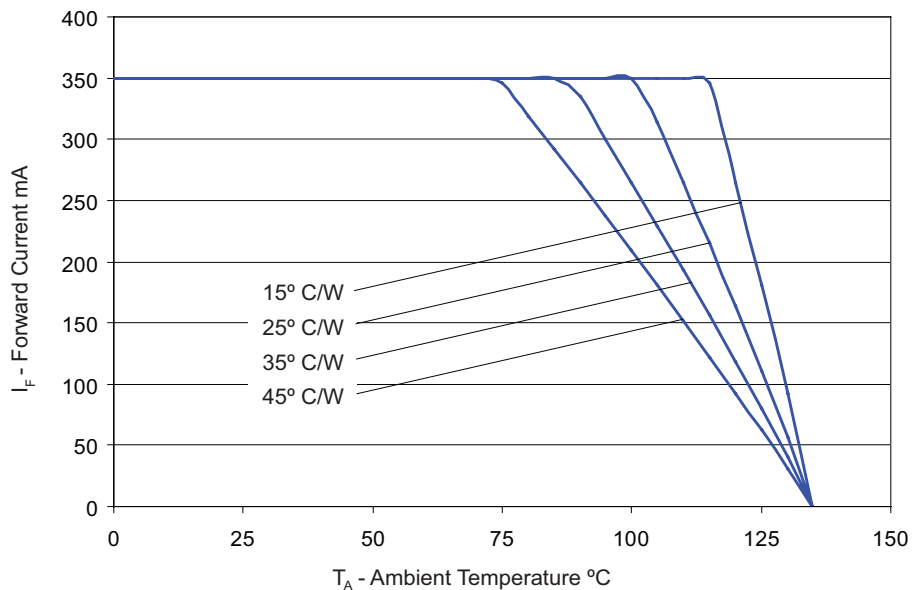

Figure 13. Maximum Forward Current vs. Ambient Temperature, Based on $T_{JMAX} = 135^{\circ}\text{C}$.

Current Derating Curves, Continued

Current Derating Curve for 700 mA Drive Current Automotive White

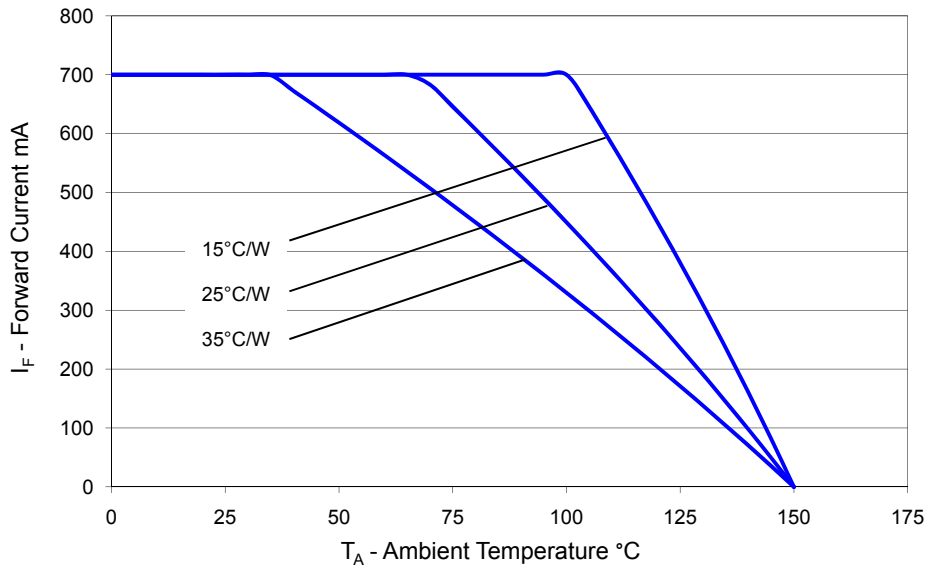

Figure 14. Maximum Forward Current vs. Ambient Temperature, Based on $T_{JMAX} = 150^\circ\text{C}$.

Current Derating Curve for 700 mA Drive Current Red-Orange and Amber

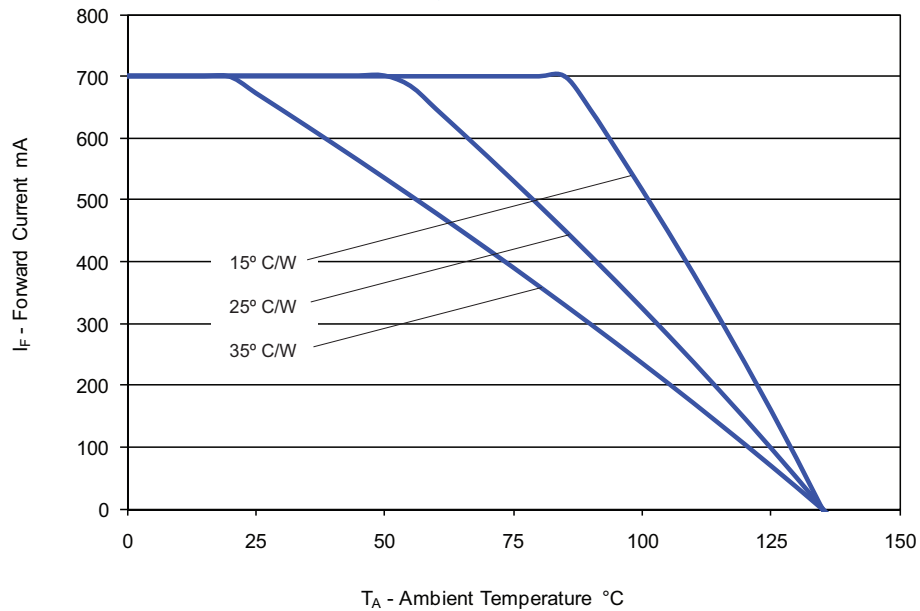

Figure 15. Maximum Forward Current vs. Ambient Temperature, Based on $T_{JMAX} = 135^\circ\text{C}$.

Typical Radiation Patterns

Typical Representative Spatial Radiation Pattern for Automotive White Lambertian

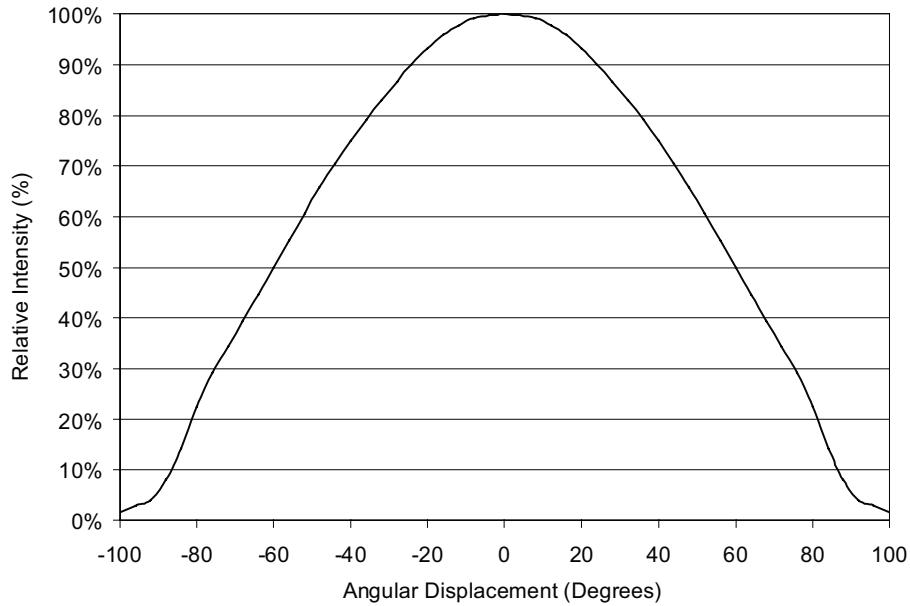

Figure 16: Typical Representative Spatial Radiation Pattern for Automotive White Lambertian.

Typical Polar Radiation Pattern for Automotive White Lambertian

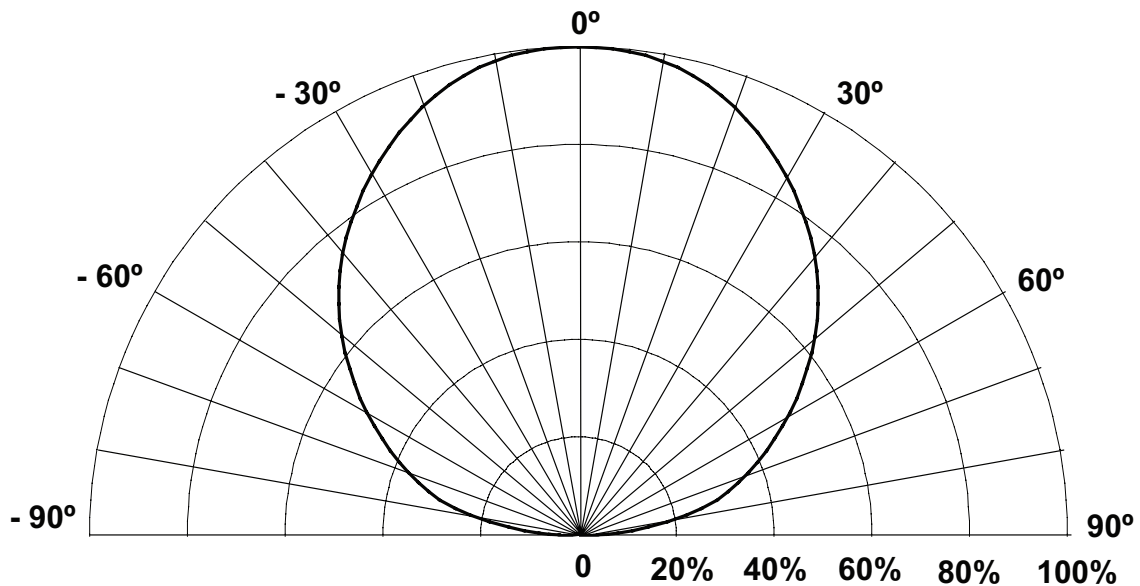

Figure 17: Typical Polar Radiation Pattern for Automotive White Lambertian.

Typical Radiation Patterns, Continued

Typical Representative Spatial Radiation Pattern for Red-Orange and Amber Lambertian

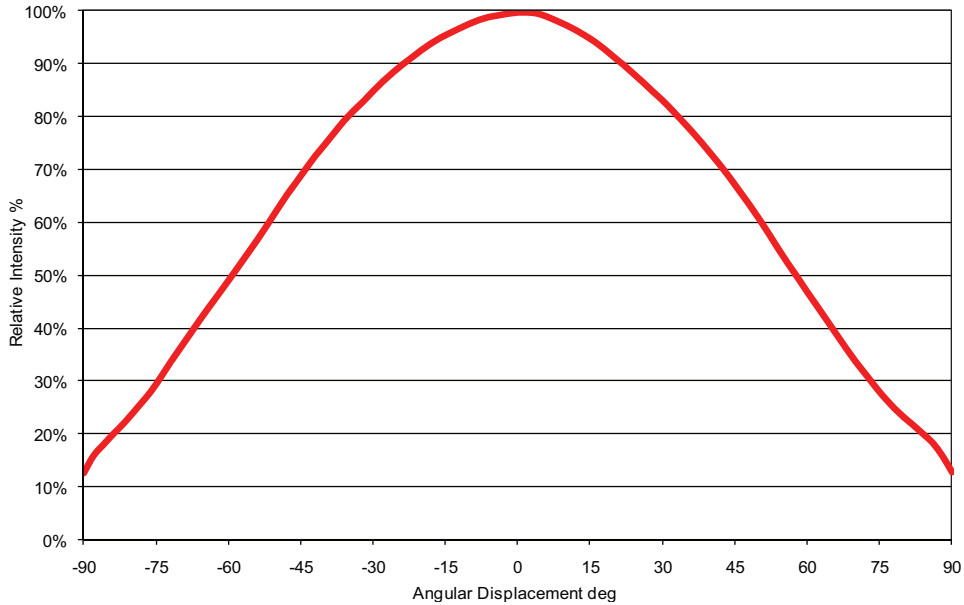

Figure 18: Typical Representative Spatial Radiation Pattern for Red-Orange and Amber Lambertian.

Typical Polar Radiation Pattern for Red-Orange and Amber Lambertian

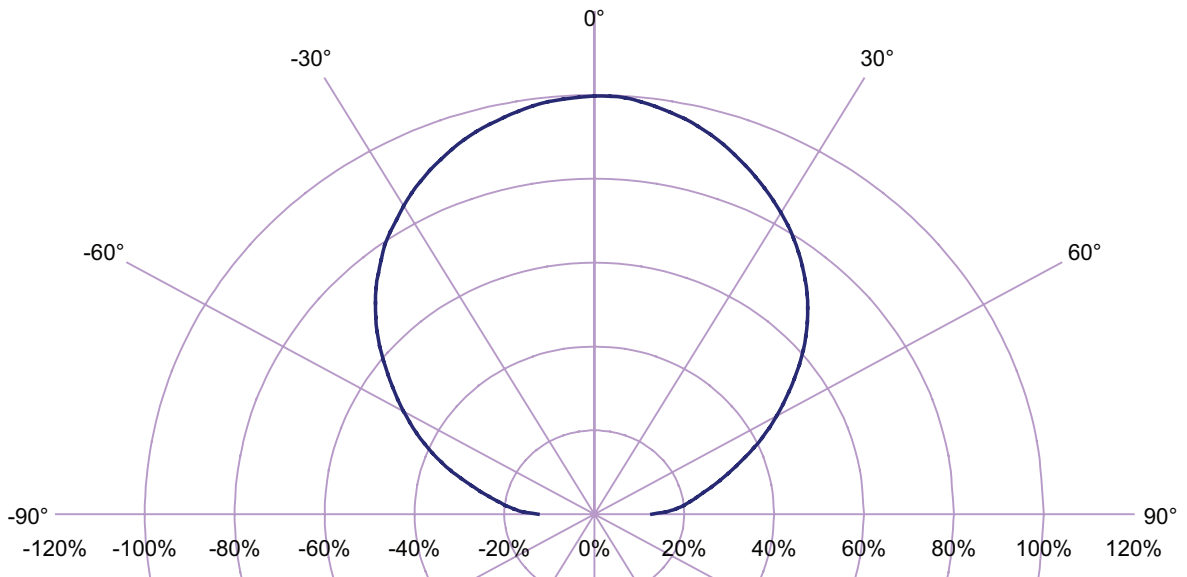

Figure 19: Typical Polar Radiation Pattern for Red-Orange and Amber Lambertian.

Emitter Pocket Tape Packaging

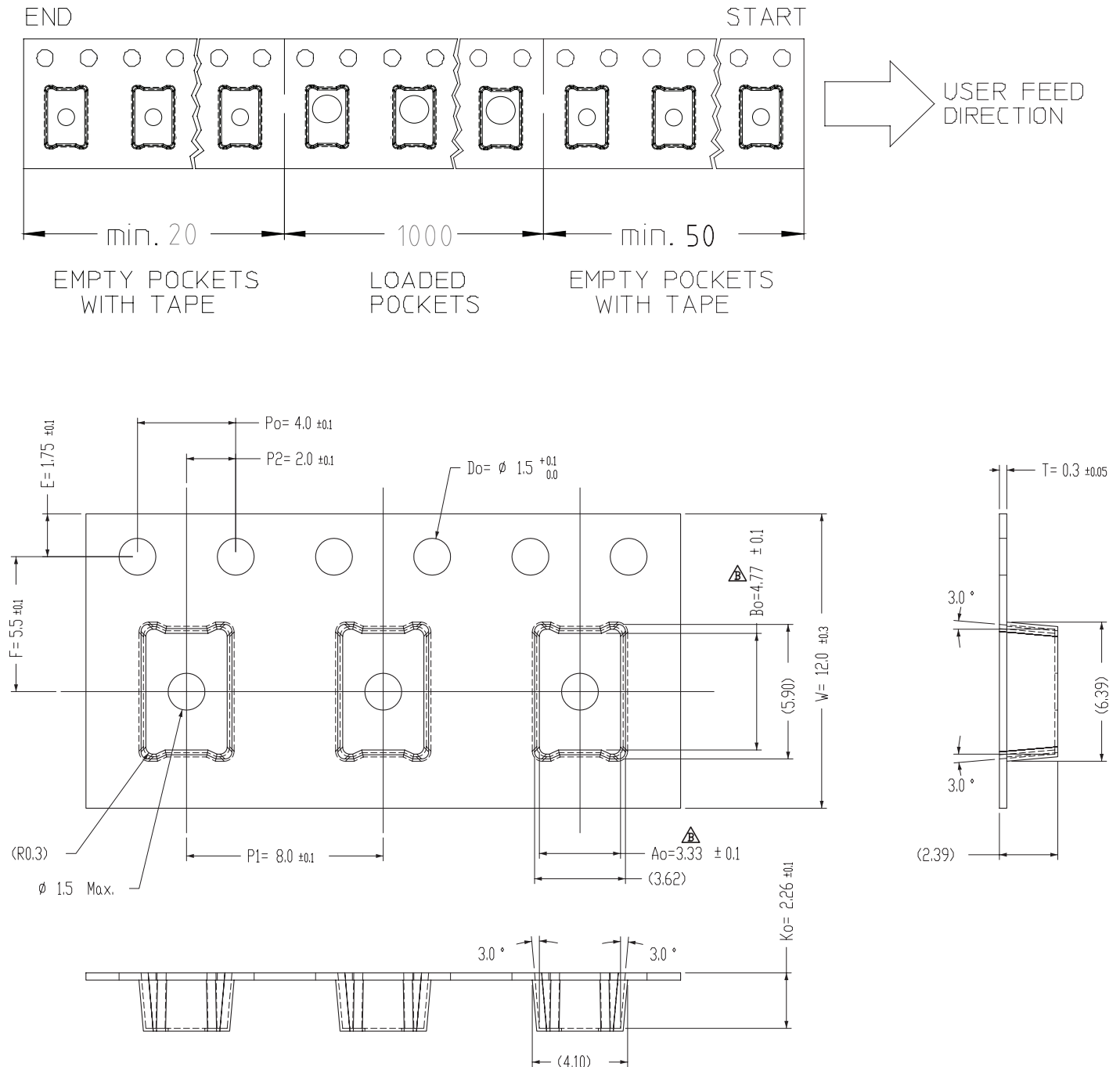

Figure 20. Emitter Pocket Tape Packaging.

Emitter Reel Packaging

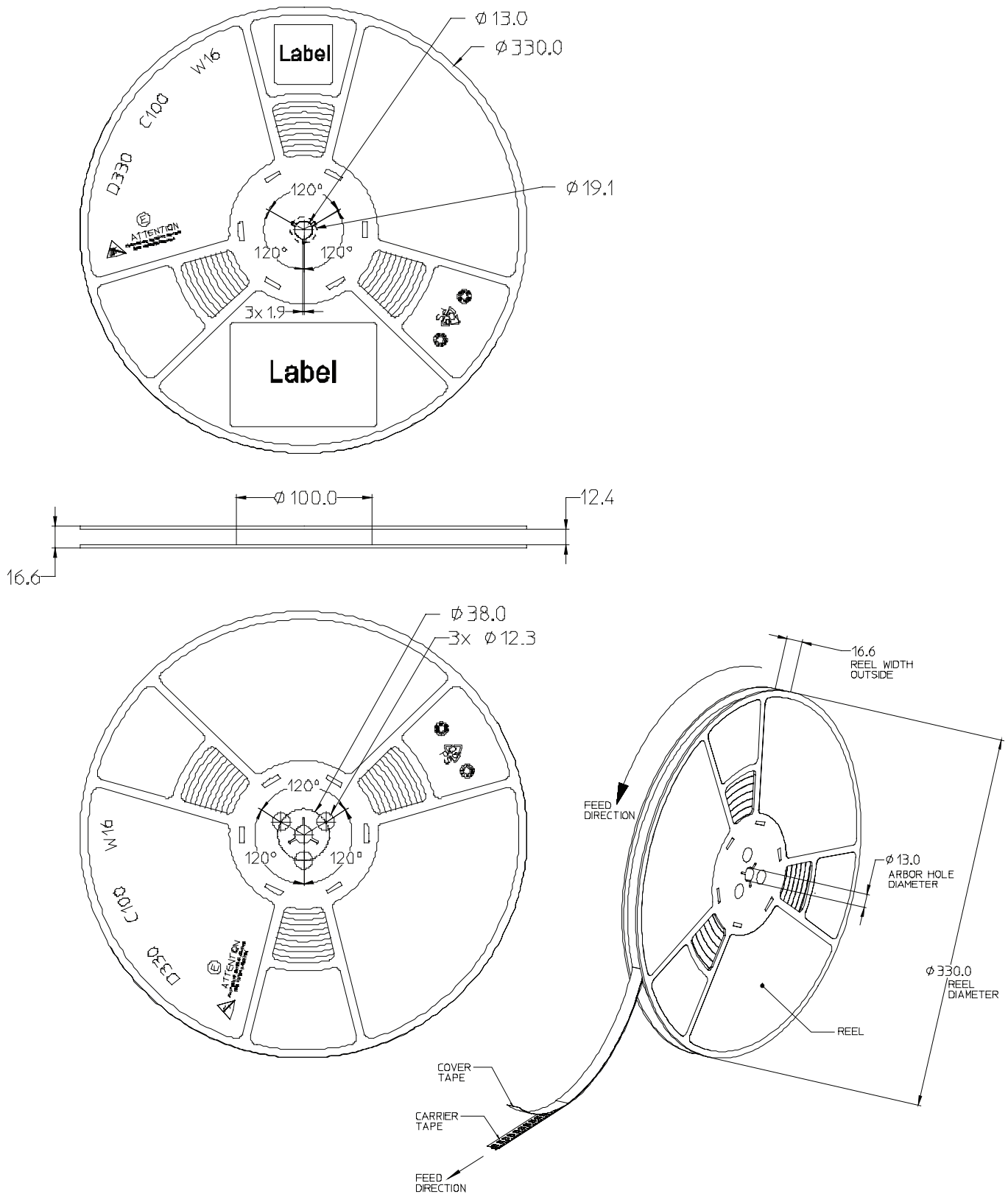

Figure 21. Emitter Reel Packaging.

Automotive Product Binning and Labeling

Purpose of Product Binning

In the manufacturing of semiconductor products, there is a variation of performance around the average values given in the technical data sheets. For this reason, Philips Lumileds bins the LED components for luminous flux, color and forward voltage (V_f).

Decoding Product Bin Labeling

LUXEON Rebel Emitters are labeled using a three or four digit alphanumeric code (CAT code) depicting the bin values for emitters packaged on a single reel. All emitters packaged within a reel are of the same 3-variable bin combination. Using these codes it is possible to determine optimum mixing and matching of products for consistency in a given application.

Format of Labeling for Emitters

Reels of Red-Orange and Amber Emitters are labeled with a three digit alphanumeric CAT code following the format below.

ABC

A = Flux bin (P, Q, R, S, etc.)

B = Color bin (2, 4, etc.)

C = V_f bin (E, F, G, etc.)

Reels of Automotive White Emitters are labeled with a four digit alphanumeric CAT code following the format below.

ABCD

A = Flux bin (P, Q, R, S, etc.)

B and C = Color bin (WN, W0, WP, WQ, VN, V0 etc.)

D = V_f bin (E, F, G, etc.)

Automotive Product Binning and Labeling, Cont'd

Luminous Flux Bins

Table 10 lists the standard photometric luminous flux bins for LUXEON Rebel emitters.

Although several bins are outlined, product availability in a particular bin varies by production run and by product performance. Not all bins are available in all colors.

Table 10.
Flux Bins - All Colors (except Royal-Blue)

Bin Code	Minimum Photometric Flux (lm)	Maximum Photometric Flux (lm)
E	23.5	30
F	30	40
G	40	50
H	50	60
J	60	70
K	70	80
L	80	90
M	90	100
N	100	120

Note for Table 10:

1. Photometric luminous flux bin structure for LUXEON Rebel emitters.

Automotive White Bin Structure

Automotive White LUXEON Rebel Emitters for Automotive applications are tested and binned by x,y coordinates.

Table I I.

Bin Code	x	y	Typical CCT (K)	Bin Code	x	y	Typical CCT (K)
A1	0.314792	0.344438	6000	A7	0.364212	0.382878	4300
	0.328823	0.356917			0.381106	0.393747	
	0.329220	0.331331			0.374075	0.365822	
	0.317466	0.320438			0.359401	0.355699	
	0.314792	0.344438			0.364212	0.382878	
A2	0.317466	0.320438	6000	A9	0.381106	0.393747	3950
	0.329220	0.331331			0.396279	0.403508	
	0.329544	0.310495			0.387071	0.373899	
	0.319597	0.301201			0.374075	0.365822	
	0.317466	0.320438			0.381106	0.393747	
A3	0.328823	0.356917	5300				
	0.346904	0.371742					
	0.344443	0.344232					
	0.329220	0.331331					
	0.328823	0.356917					

Note for Table I I:

- I. Philips Lumileds maintains a tester tolerance of ± 0.005 on x,y color coordinates.

Graphical Presentation of Automotive xy Coordinates

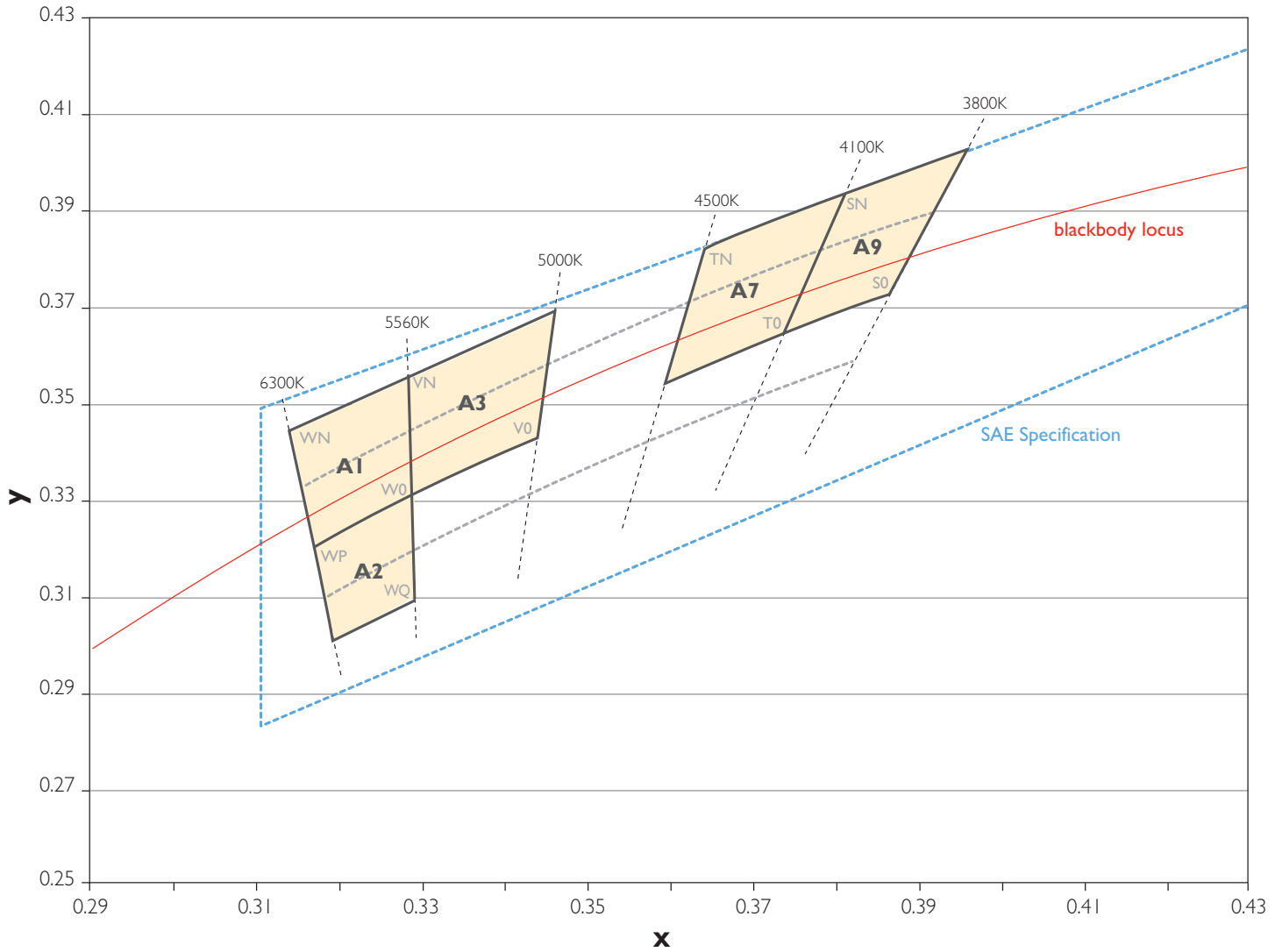

Figure 22. LUXEON Rebel White Automotive Binning Structure Graphical Representation. Coordinates Listed in Table II.

A1, A2, A3, A7, and A9 bins are supportable.

Automotive White Binning Structure (A1 ...A10) and White CAT Code Labeling Nomenclature

Table 12.

Automotive Binning Scheme	CAT Code on Product Label
A1	WN,W0
A2	WP,WQ
A3	VN,V0
A7	TN,TO
A9	SN,SO

Philips Lumileds Automotive White Color Bins (A1,A2,A3,A7,A9) are comprised of two white bins from the Philips Lumileds standard 18-Bin white binning structure (i.e.WN,W0, etc.).

A1,A2,A3,A7, and A9 bins are supportable. Binning is program specific, and will be finalized upon mutual agreement and confirmation of supportability by Philips Lumileds.

Philips Lumileds ships product tested and binned according to its standard white binning structure (WN,W0, etc.) in order to provide increased color granularity. Therefore the product label uses the standard 18-Bin white binning CAT code labeling nomenclature. Table 12 may be used to decode the standard white bins on the product label back to the new corresponding automotive bins. For more information on the Philips Lumileds standard 18-Bin white binning structure and its CAT code nomenclature please refer to AB21 on www.philipslumileds.com.

Red-Orange LUXEON Rebel Emitters for automotive applications are tested and binned for dominant wavelength.

Dominant Wavelength Bin Structure for Automotive Specification Red-Orange LUXEON Rebel

Table 13.

Bin Code	Minimum Dominant Wavelength (nm)	Maximum Dominant Wavelength (nm)
2	613.5	620.5

Amber LUXEON Rebel Emitters for automotive applications are tested and binned for dominant wavelength.

Dominant Wavelength Bin Structure for Automotive Specification Amber LUXEON Rebel

Table 14.

Bin Code	Minimum Dominant Wavelength (nm)	Maximum Dominant Wavelength (nm)
2	587.0	589.5
4	589.5	592.0

Forward Voltage Bins

Table 15 lists minimum and maximum V_f bin values per emitter. Although several bins are outlined, product availability in a particular bin varies by production run and by product performance.

Table 15.

Bin Code	Minimum Forward Voltage (V)	Maximum Forward Voltage (V)
A	2.31	2.55
B	2.55	2.79
C	2.79	3.03
D	3.03	3.27
E	3.27	3.51
F	3.51	3.75

Note for Table 15:

- I. Forward voltage bin structure for all LUXEON Rebel Automotive Emitters (Automotive White, Red-Orange and Amber).

Company Information

Philips Lumileds is the world's leading provider of power LEDs for everyday lighting applications. The company's records for light output, efficacy and thermal management are direct results of the ongoing commitment to advancing solid-state lighting technology and enabling lighting solutions that are more environmentally friendly, help reduce CO₂ emissions and reduce the need for power plant expansion. Philips Lumileds LUXEON® LEDs are enabling never before possible applications in outdoor lighting, shop lighting and home lighting.

Philips Lumileds is a fully integrated supplier, producing core LED material in all three base colors, (Red, Green, Blue) and white. Philips Lumileds has R&D centers in San Jose, California and in the Netherlands, and production capabilities in San Jose, Singapore and Penang Malaysia. Founded in 1999, Philips Lumileds is the high flux LED technology leader and is dedicated to bridging the gap between solid-state technology and the lighting world. More information about the company's LUXEON LED products and solid-state lighting technologies can be found at www.philipslumileds.com.

www.luxeon.com
www.futurelightingsolutions.com

For technical assistance or the location of your nearest sales office contact any of the following:

North America:
1 888 589 3662
americas@futurelightingsolutions.com

Europe:
00 800 443 88 873
europe@futurelightingsolutions.com

Asia Pacific:
800 5864 5337
asia@futurelightingsolutions.com

Japan:
800 5864 5337
japan@futurelightingsolutions.com

©2009 Philips Lumileds Lighting Company. All rights reserved.
Product specifications are subject to change without notice.
LUXEON is a registered trademark of the Philips Lumileds Lighting Company in the United States and other countries.

PHILIPS
LUMILEDS