

www.britool.com

**BRITTOOL**
EXPERT



Product Catalogue 2010



Britool – Professional Quality Designed For Experts

Over one hundred years have passed since the British Tool and Engineering company started manufacturing tools. A lot has changed in that time – but Britool's reputation for supplying high quality tools that stand up to the toughest challenges has stayed constant. Experts in all areas of engineering choose Britool – confident in the knowledge that it will perform to their highest expectations. To recognize the support of these generations of hardworking professionals that have helped maintain Britool at the cutting edge of industry for over a century Britool is becoming Britool Expert – in honour of their efforts.

The Britool Expert range is part of the Expert range developed by the world leader in handtools and offers a competitive, worldwide answer dedicated to professional industrial and automotive needs. The entire Expert range of tools is designed and tested to exacting specifications and achieves or exceeds ISO and DIN Standards. The Expert range will allow us to deliver an ever broadening range of products which will be constantly updated to deliver the highest levels of performance.

CONDITIONS OF SALE

Your attention is drawn to our Trading Terms and Conditions and Conditions of Sale which are printed at the back of this price list.
All registered trade marks are acknowledged. Prices do not include VAT.

CONDITIONS OF SALE

These conditions are written mainly in plain English. In these conditions “we” means Stanley UK Sales Ltd or Stanley UK Limited, subsidiaries of Stanley UK Holding Ltd, and “you” means the person who accepts a quotation for the sale of the goods and whose order for the goods is accepted by Stanley UK Sales Ltd or Stanley UK Limited.

CATALOGUE ITEMS

1. Quotations and Orders

- a) All quotations are made and orders accepted under the following conditions. We must give written agreement to new or altered conditions. All orders accepted by us are under these conditions and not your conditions.
- b) Orders must be for boxes or cartons of items. We can vary order quantities to meet this condition.
- c) You cannot return any goods unless you have our permission.
- d) Each order will be delivered to one address. We will only deliver to your address and not a third party.
- e) Once we have processed an order you cannot cancel or change it. As we continuously improve our products we can alter specifications without telling you and in these circumstances you have no right to cancel any order to claim damages.
- f) The price we charge you for the goods is the price of them on the date we send them, not the price on the date of your order. We will add V.A.T. to our prices at the proper rate on the date we send the goods.
- g) Any goods shall be sold subject only to these terms and conditions and, for the avoidance of doubt, shall not be sold upon any sale or return basis.

2. Delivery

- a) We will try to meet all delivery dates, but we are not legally liable for any delay in delivering or any losses caused by a delay. Time shall not be of the essence for delivery.
- b) Unless we agree otherwise we will deliver goods by our standard delivery service, choosing the most convenient and economical method available at the time of delivery. We will only make deliveries by other means if you ask us to and you pay.
- c) We will deliver and collect goods in normal working hours unless we have agreed otherwise. If this is inconvenient and you ask us to deliver or collect goods at a different time you will have to pay.
- d) Carriage charges are paid on all orders of a minimum nett value of £50. All orders below £50 net will be subject to a handling charge of £10.

3. Risk of Loss

- a) Once the goods have been delivered to your premises you are responsible for any loss or damage caused to the goods after you have received them.
- b) You must examine the goods immediately when they are delivered and tell us about any damage to, or shortages of, cartons within two working days. If the contents of any cartons are missing or damaged you should tell us within fifteen working days of the date of the invoice. When the goods are delivered you must also write details of any visible damage to the goods on the carrier's delivery sheet.

4. Accepting Goods

We will assume you have accepted the goods fifteen business days after they have been delivered unless you tell us about any complaints within that period. Also, if you, your agents, employees or licensees have used the goods, we will count this as accepting the goods.

5. Guarantees

- a) We only guarantee that when we deliver the goods they will not be damaged or have any faults. We are not liable for fair wear and tear.
- b) If you think that the goods are faulty you should tell us and wait for an instruction to either return the goods to a place we tell you or keep the goods for us to inspect. If we accept that there is a fault we will either repair or replace the faulty part or parts or refund the original price of the goods.
- c) The situation described in 5(b) above shall not apply to the following:
 - 1) any goods which have been repaired or altered by somebody who isn't an employee of ours.
 - 2) goods which have been mixed with other goods or used to create other products.
 - 3) any goods which, in our opinion, have been subject to any accident or to damage or which have been improperly stored, maintained or used.
- d) We are not liable for the following:
 - 1) any direct loss or damage except the liabilities we have already mentioned.
 - 2) any indirect, consequential or incidental loss or damage of any kind (including loss of profits, revenue or contracts) or for any damage to or destruction of any property.
 - 3) injury to, or the death of, any person unless that injury or death is caused by our carelessness or that of our employees.
- e) Our only guarantees, conditions and liabilities are those given in this document.
- f) You must indemnify us against all claims, actions, costs, losses, damages or expenses caused by or in connection with the goods unless we are liable under these conditions.
- g) If we repair or replace any goods under 5(b) we will take the date that the repair is finished or the goods are replaced to be the date on which the goods were delivered.

6. 'Force Majeure'

Without prejudice to any other terms of this agreement we are not liable for any act or omission or if we do not enforce, or we delay enforcing any condition in this Agreement because of any circumstances or causes beyond our control.

7. Payment

- a) Payment is due within 30 days from the date of Invoice.
- b) If you delay paying for no good reason we may choose to suspend all deliveries to you until we have received all payments which are due.
- c) If you are late with any payment we can charge interest at the rates provided in the Late Payment of Commercial Debts Act 1998.
- d) If you disagree with an invoice you must tell us about this within 7 days of receiving the goods, and that if our investigation confirms that your query is justified you do not need to pay for the amounts disputed on the invoice or any interest due.

8. Owning the Goods

- a) We own the goods until you have paid for them in full. If you pay by cheque, bill of exchange or a promissory note, we own the property until the same has been honoured. We may apply any payments you make to any of your invoices which we see fit.
- b) Until you have paid for the goods you will be acting as our fiduciary agent and bailee. You must keep records of the goods and store the goods in a way that makes them clearly identifiable as being our property. These goods should be insured by you or as part of your general insurance cover. We will assume that any goods you have which we supplied belong to us (unless you can prove otherwise).
- c) If you:
 - 1) make any arrangement with your creditors;
 - 2) go into liquidation;
 - 3) appoint a receiver to manage all or part of your assets;
 - 4) fail to make payment for the goods; or
 - 5) cannot, in our opinion pay your debts; then, we have the following rights:
 - 1) to enter any property and repossess the goods without giving you notice.
 - 2) to give you written notice that you must not sell or get rid of the goods until we have received full payment for them.
 - 3) to cancel any undelivered goods and stop any goods that are being transported to you.
- d) At any time we may give you the ownership of the goods if we give you notice of our intention to do so. Under condition 8(c) ownership of the goods will pass to you when you sell or get rid of goods which we own immediately before you sold or got rid of them.
- e) We may sue you for the price of the goods when the payment is due even though the ownership of the goods may not have passed to you.

9. We may impose restrictions on the reselling of goods, subject to U.K. and E.E.C. trading laws.

10. If any condition or part of condition in this Agreement is not valid or cannot be enforced this will not affect any part of the condition or Agreement.

11. If the ownership of your company changes we will automatically cancel this Agreement and negotiate a new one.

12. These conditions of sale only apply to your company and your own branch companies which carry out similar trade. They are not offered to your associate companies, either within or outside its trade unless we agreed this when we were negotiating this Agreement.

13. Governing Law

This Agreement, for all purposes, is governed and construed by the laws of England.



BRITOOOL EXPERT

Toolkits & Storage 2

Socketry 14

Torque Wrenches 30

Wrenches 35

Screwdrivers, Insert Bits & Keys 45

Pliers 52

Striking Tools and Cutting 56

THE BRITOOOL GUARANTEE

All Britool products are manufactured to the highest standards and are guaranteed against defective materials and workmanship when used for the purpose for which they are designed. In the unlikely event that a product fails in normal use, it will be replaced or repaired (for a full listing of the Britool guarantee, please see the listing on page 68).

Toolkits & Storage

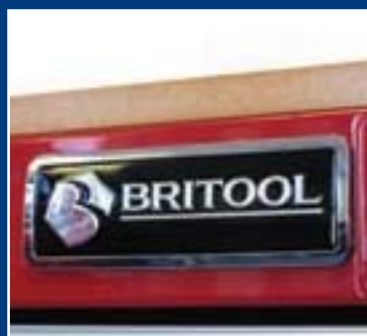
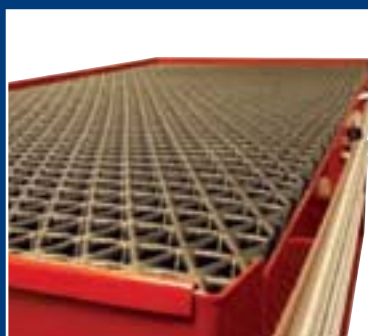

The Britool storage range includes boxes for all applications. All are manufactured under the strictest quality control environment to offer the highest standards of performance. We are confident that whatever model you select, it will provide a high quality storage solution. All Britool toolboxes featured in this section offer a number of common features:

Drawer Slides

All drawers feature high specification ball bearing drawer slides – a sure sign of quality. These allow loads of up to 30kg per drawer, and give a smooth drawer action even when fully loaded.



Rear Locking Bars

The locking mechanism activates securing bars at the rear of the drawer – making it almost impossible to force drawers open by prying.



Fully lockable

All Britool toolboxes feature high quality locks, enabling all drawers to be secured.



Full drawer extension

100% opening gives easy access – even to products stored at the very back of a drawer.



Drawer liners

All Britool toolboxes featured include high density, pre-cut drawer liners.



Manoeuvrability

All roller cabinets have heavy duty 5x2" castors. This cushions the motion of the cabinet when moved over a non smooth surface. This makes movement easier and reduces stress on the cabinet.



Side handles

All tool chests feature cushion grip side handles. Heavy duty models feature twin handles at each end.



Hinged Lids

All tool chest lids have a full width piano hinge – giving a smooth action with increased security.



Twin lid stays

For safety and durability all tool chests are fitted with two lid stays. This removes unnecessary stress from both lid and hinge whilst the lid is open – significantly increasing the life of the tool chest. Heavy duty models feature twin gas struts.



All fixings

Wheels & handles are attached using reinforced holes containing high strength precision cut threaded inserts. This simplifies the attaching or removing of components and also makes a significant contribution to units overall structural strength.

All Britool toolboxes are constructed from heavy gauge steel – giving unrivaled durability.



- Heavy duty construction designed for heavy use
- Heavy duty ball bearing drawer slides
- Powder coat finish – for improved corrosion resistance
- Heavy duty castors
- Double wall construction – for increased strength and reliability
- Drawer liners included
- Storage compartment

3 Drawer Roller Cabinet

Ref.	Description	Width mm	Depth mm	Height mm
BRCR3	Overall Dimensions	676	460	676
	3 Drawers	569	412	75



- Heavy duty construction designed for heavy use
- Heavy duty ball bearing drawer slides
- Powder coat finish – for improved corrosion resistance
- Heavy duty castors
- Double wall construction – for increased strength and reliability
- Drawer liners included

5 Drawer Roller Cabinet

Ref.	Description	Width mm	Depth mm	Height mm
BRCR5	Overall Dimensions	676	460	860
	3 Drawers	569	412	75
	2 Drawers	569	412	155



- Heavy duty construction designed for heavy use
- Heavy duty ball bearing drawer slides
- Powder coat finish – for improved corrosion resistance
- Heavy duty castors
- Double wall construction – for increased strength and reliability
- Drawer liners included

5 Drawer Roller Cabinet

Ref.	Description	Width mm	Depth mm	Height mm
BRCR5BL	Overall Dimensions	676	460	860
	3 Drawers	569	412	75
	2 Drawers	569	412	155



- Heavy duty construction designed for heavy use
- Heavy duty ball bearing drawer slides
- Powder coat finish – for improved corrosion resistance
- Heavy duty castors
- Double wall construction – for increased strength and reliability
- Drawer liners included

5 Drawer Roller Cabinet with Storage Compartment

Ref.	Description	Width mm	Depth mm	Height mm
BRCR6	Overall Dimensions	676	460	995
	4 Drawers	569	412	75
	1 Drawer	569	412	154
	Storage Compartment	569	412	358



- Heavy duty construction designed for heavy use
- Heavy duty ball bearing drawer slides
- Powder coat finish – for improved corrosion resistance
- Heavy duty castors
- Double wall construction – for increased strength and reliability
- Drawer liners included

5 Drawer Roller Cabinet with Storage Compartment

Ref.	Description	Width mm	Depth mm	Height mm
BRCR6BL	Overall Dimensions	676	460	995
	4 Drawers	569	412	75
	1 Drawer	569	412	154
	Storage Compartment	569	412	358



- Heavy duty construction designed for heavy use
- Heavy duty ball bearing drawer slides
- Powder coat finish – for improved corrosion resistance
- Heavy duty castors
- Double wall construction – for increased strength and reliability
- Drawer liners included

11 Drawer Roller Cabinet

Ref.	Description	Width mm	Depth mm	Height mm
BRCR11	Overall Dimensions	676	460	1105
	4 Drawers	268	412	50
	5 Drawers	569	412	75
	2 Drawers	569	412	155



- Heavy duty construction designed for heavy use
- Heavy duty ball bearing drawer slides
- Powder coat finish – for improved corrosion resistance
- Heavy duty castors
- Double wall construction – for increased strength and reliability
- Drawer liners included

11 Drawer Roller Cabinet

Ref.	Description	Width mm	Depth mm	Height mm
BRCR11BL	Overall Dimensions	676	460	1105
	4 Drawers	268	412	50
	5 Drawers	569	412	75
	2 Drawers	569	412	155



- Heavy duty construction designed for heavy use
- Heavy duty ball bearing drawer slides
- Powder coat finish – for improved corrosion resistance
- Heavy duty castors
- Double wall construction – for increased strength and reliability
- Drawer liners included

7 Drawer Roller Cabinet

Ref.	Description	Width mm	Depth mm	Height mm
BRCR7	Overall Dimensions	676	460	995
	5 Drawers	569	412	75
	2 Drawers	569	412	155



- Heavy duty construction designed for heavy use
- Heavy duty ball bearing drawer slides
- Powder coat finish – for improved corrosion resistance
- Heavy duty castors
- Double wall construction – for increased strength and reliability
- Drawer liners included

7 Drawer Roller Cabinet

Ref.	Description	Width mm	Depth mm	Height mm
BRCR7BL	Overall Dimensions	676	460	995
	5 Drawers	569	412	75
	2 Drawers	569	412	155



- 13 Drawer 41" Tool Cart - Black
- Heavy duty construction designed for heavy use
- Heavy duty ball bearing drawer slides
- Powder coat finish – for improved corrosion resistance
- Heavy duty castors
- Double wall construction

13 Drawer 41" Tool Cart

Ref.	Description	Width mm	Depth mm	Height mm
BTCR13BL	Overall Dimensions	1067	480	1010
	1 Drawers	308	412	155
	1 Drawers	569	412	155
	5 Drawer	569	412	75
	5 Drawer	308	412	75
	1 Drawer	935	412	120



- Heavy duty construction designed for heavy use
- Heavy duty ball bearing drawer slides
- Powder coat finish – for improved corrosion resistance
- Heavy duty castors
- Double wall construction – for increased strength and reliability
- Drawer liners included

16 Drawer 41" Tool Cart

Ref.	Description	Width mm	Depth mm	Height mm
BTCR16	Overall Dimensions	1067	480	1010
	7 Drawers	569	412	75
	7 Drawers	308	412	75
	1 Drawer	569	412	155
	1 Drawer	308	412	155



- Heavy duty construction designed for heavy use
- Gas lid struts- for ease of opening
- Heavy duty ball bearing drawer slides
- Powder coat finish – for improved corrosion resistance
- Double wall construction – for increased strength and reliability
- Drawer liners included

8 Drawer 41" Tool Chest

Ref.	Description	Width mm	Depth mm	Height mm
BTBR8W	Overall Dimensions	1052	470	492
	4 Drawers	569	412	75
	4 Drawers	308	412	75



- Heavy duty construction designed for heavy use
- Gas lid struts- for ease of opening
- Heavy duty ball bearing drawer slides
- Powder coat finish – for improved corrosion resistance
- Double wall construction – for increased strength and reliability
- Drawer liners included

8 Drawer 41" Tool Chest

Ref.	Description	Width mm	Depth mm	Height mm
BTBR8WBL	Overall Dimensions	1052	470	492
	4 Drawers	569	412	75
	4 Drawers	308	412	75



- Heavy duty construction designed for heavy use
- Tote tray included
- Heavy duty ball bearing drawer slides
- Powder coat finish – for improved corrosion resistance
- Double wall construction – for increased strength and reliability
- Drawer liners included

10 Drawer Tool Chest

Ref.	Description	Width mm	Depth mm	Height mm
BTBR10	Overall Dimensions	660	410	490
	6 Drawers	169	368	50
	1 Drawer	169	368	154
	3 Drawers	569	368	75



- Heavy duty construction designed for heavy use
- Tote tray included
- Heavy duty ball bearing drawer slides
- Powder coat finish – for improved corrosion resistance
- Double wall construction – for increased strength and reliability
- Drawer liners included

10 Drawer Tool Chest

Ref.	Description	Width mm	Depth mm	Height mm
BTBR10BL	Overall Dimensions	660	410	490
	6 Drawers	169	368	50
	1 Drawers	169	368	154
	3 Drawers	569	368	75



- Heavy duty construction designed for heavy use
- Drop down front for complete security
- Tote tray included
- Heavy duty ball bearing drawer slides
- Powder coat finish – for improved corrosion resistance
- Double wall construction – for increased strength and reliability
- Drawer liners included

6 Drawer Tool Chest With Drop Down Front

Ref.	Description	Width mm	Depth mm	Height mm
BTBRD6	Overall Dimensions	660	307	386
	3 Drawers	169	272	50
	2 Drawers	569	272	50
	1 Drawer	569	272	75



- Heavy duty construction designed for heavy use
- Drop down front for complete security
- Tote tray included
- Heavy duty ball bearing drawer slides
- Powder coat finish – for improved corrosion resistance
- Double wall construction – for increased strength and reliability
- Drawer liners included

6 Drawer Tool Chest With Drop Down Front

Ref.	Description	Width mm	Depth mm	Height mm
BTBRD6BL	Overall Dimensions	660	307	386
	3 Drawers	169	272	50
	2 Drawers	569	272	50
	1 Drawer	569	272	75



- Heavy duty construction designed for heavy use
- Tote tray included
- Heavy duty ball bearing drawer slides
- Powder coat finish – for improved corrosion resistance
- Double wall construction – for increased strength and reliability
- Drawer liners included

8 Drawer Tool Chest

Ref.	Description	Width mm	Depth mm	Height mm
BTBR8	Overall Dimensions	660	307	386
	6 Drawers	169	272	50
	2 Drawers	569	272	75



- Heavy duty construction designed for heavy use
- Heavy duty ball bearing drawer slides
- Powder coat finish – for improved corrosion resistance
- Double wall construction – for increased strength and reliability
- Drawer liners included

8 Drawer Side Cabinet

Ref.	Description	Width mm	Depth mm	Height mm
BSCR8	Overall Dimensions	377	470	860
	7 Drawers	308	412	75
	1 Drawers	308	412	155



- Heavy duty construction designed for heavy use
- Heavy duty ball bearing drawer slides
- Powder coat finish – for improved corrosion resistance
- Double wall construction – for increased strength and reliability
- Drawer liners included

8 Drawer Side Cabinet

Ref.	Description	Width mm	Depth mm	Height mm
BSCR8BL	Overall Dimensions	377	470	860
	7 Drawers	308	412	75
	1 Drawers	308	412	155



- Powder coat finish – for improved corrosion resistance
- With internal shelf
- Easily attached to roller cabinet (min depth 458mm, min height 875mm)

Side Cabinet

Ref.	Description	Width mm	Depth mm	Height mm
BSCR1	Overall Dimensions	375	458	860



- Powder coat finish – for improved corrosion resistance
- With internal shelf
- Easily attached to roller cabinet (min depth 458mm, min height 875mm)

Side Cabinet

Ref.	Description	Width mm	Depth mm	Height mm
BSCR1BL	Overall Dimensions	375	458	860



- Heavy duty construction designed for heavy use
- Heavy duty ball bearing drawer slides
- Powder coat finish – for improved corrosion resistance
- Double wall construction – for increased strength and reliability
- Drawer liners included

3 Drawer Full Depth Mid Section

Ref.	Description	Width mm	Depth mm	Height mm
BMSR3FD	Overall Dimensions	660	415	270
	2 Drawers	573	368	50
	1 Drawer	573	368	75



- Heavy duty construction designed for heavy use
- Heavy duty ball bearing drawer slides
- Powder coat finish – for improved corrosion resistance
- Double wall construction – for increased strength and reliability
- Drawer liners included

3 Drawer Full Depth Mid Section

Ref.	Description	Width mm	Depth mm	Height mm
BMSR3FDBL	Overall Dimensions	660	415	270
	2 Drawers	573	368	50
	1 Drawer	573	368	75



- Heavy duty construction designed for heavy use
- Heavy duty ball bearing drawer slides
- Powder coat finish – for improved corrosion resistance
- Double wall construction – for increased strength and reliability
- Drawer liners included

3 Drawer Mid Section

Ref.	Description	Width mm	Depth mm	Height mm
BMSR6	Overall Dimensions	660	315	270
	2 Drawers	573	262	50
	1 Drawer	573	262	75



- Heavy duty construction designed for heavy use
- Heavy duty ball bearing drawer slides
- Powder coat finish – for improved corrosion resistance
- Double wall construction – for increased strength and reliability
- Drawer liners included

3 Drawer Mid Section

Ref.	Description	Width mm	Depth mm	Height mm
BMSR6BL	Overall Dimensions	660	315	270
	2 Drawers	573	262	50
	1 Drawer	573	262	75



- Heavy duty construction designed for heavy use
- Heavy duty ball bearing drawer slides
- Powder coat finish – for improved corrosion resistance
- Double wall construction – for increased strength and reliability
- Drawer liners included

8 Drawer Mid Section

Ref.	Description	Width mm	Depth mm	Height mm
BMSR8	Overall Dimensions	1058	470	440
	4 Drawers	569	412	75
	4 Drawer	308	412	75



- Powder coat finish – for improved corrosion resistance
- Easily attached to roller cabinet
- Dimensions : 430 x 90 x 90mm

Tool And Can Holder And Can Holder

Ref.	Dimensions mm
BCH1	430 x 90 x 90



- Powder coat finish – for improved corrosion resistance
- Can be folded down when not in use

Side Shelf

Ref.	Description	Width mm	Depth mm
BSH1	Side Shelf	405	434



Side Shelf

Ref.	Description	Width mm	Depth mm
BSH1BL	Side Shelf	405	434

BRKIT80



8 Drawer Tool Chest and 76 Piece Toolkit

Ref.	Contents
BRKIT80	<ul style="list-style-type: none"> • 8 Drawer tool chest (BTBR8) • 60 Piece 3/8" SD metric socket set (748261) • 7 Piece metric combination wrench set (ND336T) • 16oz Ball pein hammer (BPH16) • 8 Piece Phillips & slotted screwdriver set (SDRIV4)

BRKIT228



5 Drawer Roller Cabinet and 227 Piece Toolkit

Ref.	Contents
BRKIT228	<ul style="list-style-type: none"> • 5 Drawer roller cabinet with storage compartment (BRCR6) • 46 Piece 1/4" SD metric socket set (748254) • 26 Piece 1/2" SD metric socket set (748271) • Ratcheting screwdriver – with 6 piece bit set (BRSD2) • 12 piece metric ratcheting combination wrench set (RRJMSET1) • 12 Piece metric combination wrench set (ND349K) • 12" Adjustable wrench (312C) • 9 Piece ball ended metric hexagon socket set (HKMB9/C) • 16oz Ball pein hammer (BPH16) • 32oz Ball pein hammer (BPH32) • 8 Piece Phillips & slotted screwdriver set (SDRIV4) • Reversed bow hacksaw (HS212), 109 Piece insert bit set (BBS109)

BRKIT338



11 Drawer Roller Cabinet and 330 Piece Toolkit

Ref.	Contents
BRKIT338	<ul style="list-style-type: none"> • 11 Drawer roller cabinet (BRCR11) • 110 Piece 1/4" and 1/2" SD metric socket set (748291) • 60 Piece 3/8" SD metric socket set (748261) • 17 Piece metric combination wrench set (ND360E) • 12 Piece flexible ratcheting combination wrench set (RRFJMSET12) • 109 Piece insert bit set (BBS109) • Adjustable grip ratcheting screwdriver (BRSDF1) • 16 & 32oz Ball pein hammers (BPH16, BPH32) • 42oz Dead blow hammer (DBH42) • 8 Piece Phillips and slotted screwdriver set (SDRIV4) • 7 Piece stubby screwdriver set (SDRIV6) • 8" and 12" Adjustable wrenches (308C, 312C)

11 Drawer Roller Cabinet and 447 Piece



BRKIT447

Ref.	Contents
BRKIT447	<ul style="list-style-type: none"> • 11 Drawer roller cabinet (BRCR11) • 56 Piece 1/2" SD metric and AF socket set (748274) • 88 Piece 3/8" SD metric and AF socket set (748267) • 77 Piece 1/4" SD metric and AF socket set (748256) • 1/2" SD 600mm swivel handle (E86) • 17 Piece metric combination wrench set (ND360E) • 10 Piece AF combination wrench set (ND243L) • 10 Piece extra long metric combination wrench set (RJM10/S) • 12 Piece metric flexible ratcheting combination wrench set (RRJMSET12) • 5 Piece metric double ended ratcheting wrench set (RRMSET5) • 109 Piece insert bit set (BBS109) • 3 Piece plier set (PLIER2) • Reversed bow hacksaw (HS212) • 8, 16 & 32oz Ball pein hammers (BPH8, 16, 32) • 9 Piece ball ended metric hexagon key set (HKMB9/C) • 8 Piece slotted and Phillips screwdriver set (SDRIV4) • 7 Piece tamper proof torx screwdriver set (SDRIV5) • 7 Piece stubby screwdriver set (SDRIV6) • 18 Piece stubby ratcheting screwdriver set BRSDSET2) • 8", 12" and 15" Adjustable wrenches (308C, 312C, 315C) • 3 Piece screwdriver handled pry bar set (SPBSET)



BRKIT314

11 Drawer Roller Cabinet and 314 Piece Toolkit

Ref.	Contents
BRKIT314	<ul style="list-style-type: none"> • 11 Drawer roller cabinet (BRCR11) • 56 Piece 1/2" SD metric and AF socket set (748274) • 77 Piece 1/4" SD metric and AF socket set (748256) • 1/2" SD 600mm swivel handle (E86) • 17 Piece metric combination wrench set (ND360E) • 12 Piece metric flexible ratcheting combination wrench set (RRJMSET1) • 5 Piece metric double ended ratcheting wrench set (RRMSET5) • 109 Piece insert bit set (BBS109) • 3 Piece plier set (PLIER2) • Reversed bow hacksaw (HS212) • 8, 16 & 32oz Ball pein hammers (BPH8, 16, 32) • 9 Piece ball ended metric hexagon key set (HKMB9/C) • 8 Piece slotted and Phillips screwdriver set (SDRIV4) • 7 Piece tamper proof torx screwdriver set (SDRIV5) • 7 Piece stubby screwdriver set (SDRIV6) • 8", 12" and 15" Adjustable wrenches (308C, 312C, 315C)



BRKIT239

3 Drawer Roller Cabinet and 237 Piece Toolkit

Ref.	Contents
BRKIT239	<ul style="list-style-type: none"> • 3 Drawer Roller Cabinet with storage compartment (BRCR3) • 60 Piece 3/8" SD metric socket set (748261) • 46 Piece 1/4" SD metric socket set (748254) • 12 Piece metric combination wrench set (ND349K) • 16oz Ball pein hammer (BPH16) • 8 Piece Phillips & slotted screwdriver set (SDRIV4, Reversed bow hacksaw (HS212) • 109 Piece insert bit set (BBS109)



BRKIT470



BRKIT470

16 Drawer Tool Cart and 470 Piece Toolkit

Ref.	Contents
BRKIT470	<p>• 11 Drawer roller cabinet (BTCR16) • 56 Piece 1/2" SD metric and AF socket set (748274) • 88 Piece 3/8" SD metric and AF socket set (748267) • 77 Piece 1/4" SD metric and AF socket set (748256) • 1/2" SD 600mm swivel handle (E86) • 17 Piece metric combination wrench set (ND360E) • 10 Piece AF combination wrench set (ND243L) • 10 Piece extra long metric combination wrench set (RJXM10/S) • 10 Piece metric ring wrench set (NC389N) • 10 Piece metric open jaw wrench set (S2JM10) • 12 Piece metric flexible ratcheting combination wrench set (RRJMSET1) • 5 Piece metric double ended ratcheting wrench set (RRMSET5) • 109 Piece insert bit set (BBS109) • 3 Piece plier set (PLIER2) • Reversed bow hacksaw (HS212) • 8, 16 & 32oz Ball pein hammers (BPH8, 16, 32) • 9 Piece ball ended metric hexagon key set (HKMB9/C) • 8 Piece slotted and Phillips screwdriver set (SDRIV4) • 7 Piece tamper proof torx screwdriver set (SDRIV5) • 7 Piece stubby screwdriver set (SDRIV6) • 18 Piece stubby ratcheting screwdriver set BRSDSET2) • 8", 12" and 15" Adjustable wrenches (308C, 312C, 315C) • 3 Piece screwdriver handled pry bar set (SPBSET) • Lock grip pliers – 190mm curved jaw and 235mm straight jaw (PM900 & PM903)</p>

- Pro quality utility boxes
- Strong carrying handle
- Toggle catches for security

CTB45



Cantilever Tool Boxes

Ref.	Description	Width mm	Depth mm	Height mm	kg
CTB45	Cantilever Tool Box	450	210	205	4

Socketry



Specification

Britool sockets and accessories are manufactured from the highest quality materials using the latest techniques. All areas of the production process are subject to the highest quality control standards.

All Britool sockets and accessories should meet the highest performance expectations and are manufactured to the latest international standards.

Innovative features have been incorporated into product design wherever possible in order to give the greatest levels of functionality and ensure optimum performance.



Stress Relief Drive

Britool's advanced socket profile configuration increases the contact area between the socket and the fastener, minimising stress, and reducing the chance of damage to the fastener.

The load is applied to the fastener's flat edge rather than the corners: even if the fastener is already damaged, performance will be superior to that of a standard-profile socket.

Conventional Profile

Corner point contact gives high stress areas – highlights show contact points on the corner of the fastener

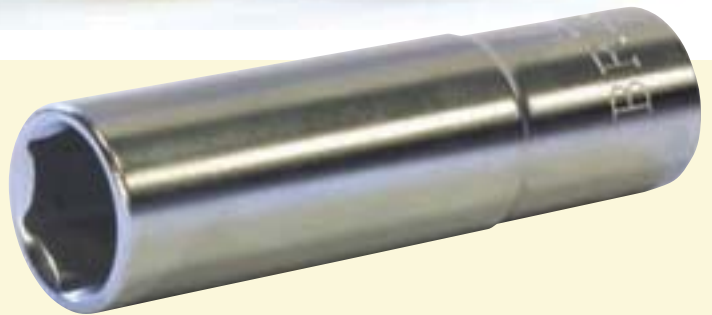

SRD Profile

Distributed surface loads relieves possible stress area – highlights show contact points away from the corner of the fastener

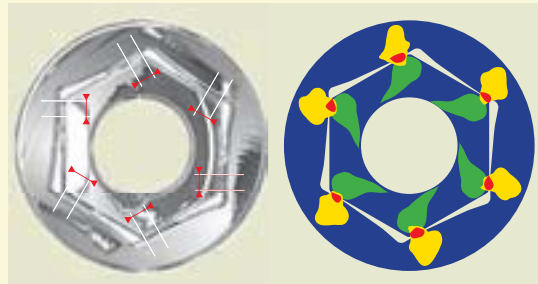

Forging Technology

Where possible, Britool products are forged from a single piece of steel, using the most appropriate technology.

The best forging solution gives the most uniform, linear grain flow—only this will give the highest levels of strength and durability.

This can be compared to the grain flow in wood—a shape with uninterrupted grain, grown into a shape, will always be stronger than one that has been cut, and liable to split across the grain.

To achieve high levels of grain flow uniformity, Britool uses several different methods dependant on the shape required—traditional drop forging, upset forging and cold forging.



Ratchets

In order to offer outstanding choice and ensure that the correct tool is always available, Britool offers a variety of ratchet styles and mechanisms:

Lever Reversible Ratchet

This extremely strong mechanism is available in 1/4", 3/8" and 1/2" drive. The 72 tooth design offers a minimum working arc of 5°. The mechanism is extremely smooth, and gives an almost negligible reverse torque—removing the risk of accidentally undoing the fastener on the reverse stroke. The twin pawl mechanism of this ratchet uses a different pawl for each direction of travel. This means that each is ideally positioned to take the greatest possible load—making it almost impossible to overload this ratchet design in normal use. Thumb lever controlled reversible action.



Clutch Ratchet

A highly innovative, simple, robust design, this roller bearing mechanism is available in 1/4", 3/8" and 1/2" square drive. The toothless nature of this ratchet gives a silent and smooth action with a minimum working arc of less than 1°—this is the ultimate ratchet for use where access is restricted. The design features a push through square drive to change direction.

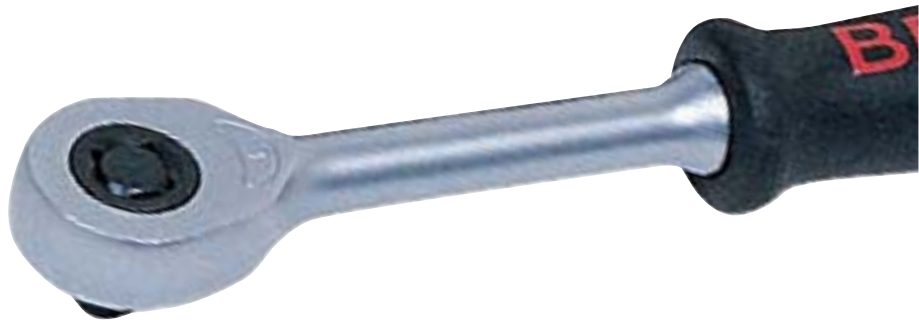

Swivel Head Ratchet

This ratchet design is available in 1/4", 3/8" and 1/2" square drive. It features a 72 tooth mechanism – offering a minimum working arc of 5°. Despite its compact size, the mechanism offers extremely good load characteristics – 17 teeth are engaged during loading, giving 45% more strength than most conventional ratchets. The swivel head design offers unrivalled access.



Flexi-Head Ratchet

Available in 3/8" and 1/2", this high strength design features the same mechanism as the lever reversible ratchet, coupled with a long handle and a flexible head – giving great access characteristics and allowing high torque loads.



Lock-on Quick Release Mechanism

The lever-reversible ratchet design is also available with a quick release mechanism which locks the socket in place, making accidental loss of the socket virtually impossible.

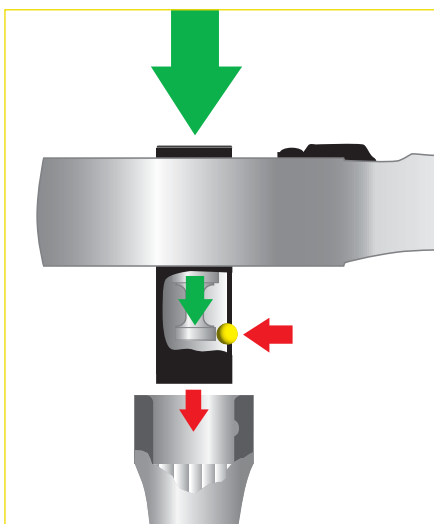

1/4" Square Drive Accessories

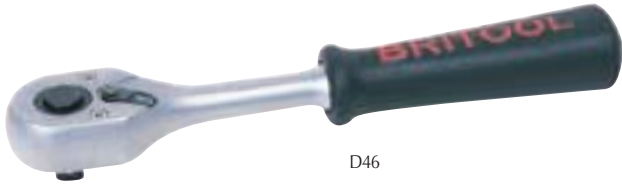

D46

1/4" SD Lock-On Reversible Ratchet

Ref	Description
D46	Polypropylene handle – resistant to hydrocarbons, 72 Tooth mechanism - 5° minimum working arc, Lock-On design, Thumb reversible



1/4" SD Clutch Ratchet

Ref	Description
D77	Polypropylene handle – resistant to hydrocarbons, Roller bearing mechanism, Push-thru reversible mechanism, Thumb reversible



1/4" SD Swivel Headed Reversible Ratchet

Ref	Description
DFS20	Polypropylene handle – resistant to hydrocarbons, 72 Tooth mechanism - 5° minimum working arc, Swivel head design for improved access



5 Piece Palm Ratchet Set

Ref	Description
DASET5P	0mm & 13mm low profile finger ratchets 10mm x 1/4" Square drive adapter - to make 1/4" SD palm ratchet, 13mm x 3/8" Square drive adapter - to make 3/8" SD palm ratchet, 10mm x 1/4" Hex drive adapter - to make palm bit driver



1/4" SD Sliding T Handle

Ref	Description
D70	Manufactured to DIN3122



1/4" SD Universal Joint

Ref	Description
D91	High strength design, Manufactured to DIN3123

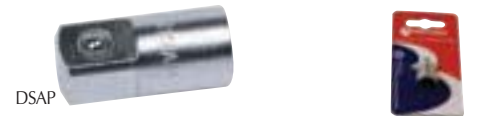

1/4" SD Female – 3/8" SD Male Converter

Ref	Description
DSAP	Used to drive 3/8" accessories using a 1/4" input, Manufactured to DIN3123



3/8" SD Female – 1/4" SD Male Converter

Ref	Description
DPAS	Used to drive 1/4" accessories using a 3/8" input, Manufactured to DIN3123

Bit Holders

Ref.	[F] Hex AF	[M] Hex AF	Length mm
DIUBA	1/4"	1/4"	22



3 Piece 1/4" Square Drive Extension Bar Set

Ref	Description
708510	3 1/4" SD Extension bars 50mm, 75mm and 150mm



13 Piece 1/4" Square Drive Metric Socket Set

Ref	Contents
708010	13 1/4" SD Cold forged metric hexagon sockets 4, 4.5, 5, 5.5, 6, 7, 8, 9, 10, 11, 12, 13, 14mm



9 Piece 1/4" Square Drive AF Socket Set

Ref	ContentsList
708020	9 1/4" SD Cold forged AF hexagon sockets 3/16, 7/32, 1/4, 9/32, 5/16, 11/32, 3/8, 7/16, 1/2"



10 Piece 1/4" Square Drive Deep Metric Socket Set

Ref	Contents
708030	10 1/4" SD Cold forged deep metric hexagon sockets 5, 5.5, 6, 7, 8, 9, 10, 11, 12, 13mm



8 Piece 1/4" Square Drive Hexagon Bit Socket Set

Ref.	Contents
708040	8 Hexagon bit sockets 2, 2.5, 3, 4, 5, 6, 7, 8mm



18 Piece 1/4" Square Drive Metric Socket Set

Ref	Contents
748251	<ul style="list-style-type: none"> 1/4" SD Quick release ratchet • 13 1/4" SD Cold forged metric hexagon sockets 4, 4.5, 5, 5.5, 6, 7, 8, 9, 10, 11, 12, 13, 14mm 2 1/4" SD Extension bars 50mm and 150mm • 1/4" SD Universal joint • 1/4" SD - 1/4" Hexagon drive bit holder



27 Piece 1/4" Square Drive Metric and AF Socket Set

Ref	ContentsList
748252	1/4" SD Quick release ratchet • 13 1/4" SD Cold forged metric hexagon sockets 4, 4.5, 5, 5.5, 6, 7, 8, 9, 10, 11, 12, 13, 14mm • 9 1/4" SD Cold forged AF hexagon sockets • 3/16, 7/32, 1/4, 9/32, 5/16, 11/32, 3/8, 7/16, 1/2", 2 1/4" SD Extension bars 50mm and 150mm • 1/4" SD Universal joint • 1/4" SD - 1/4" Hexagon drive bit holder

1/4" Square Drive Socket Sets



46 Piece 1/4" Square Drive Metric Socket Set

Ref	Contents
748254	<ul style="list-style-type: none"> • Quick release ratchet • 2 Extension Bars 50&100mm • Flexible Extension 150mm • Spinner Handle • Sliding T Handle • Universal joint • 1/4" Hex-1/4" Square Adapter • 4 Hexagon Keys 1.3, 1.5, 2, 2.5mm • 13 Metric Sockets 4, 4.5, 5, 5.5, 6, 7, 8, 9, 10, 11, 12, 13, 14mm • 6 Torx Bit Sockets T10, 15, 20, 25, 30, 40 • 6 Hexagon Bit Sockets 3, 4, 5, 6, 7, 8mm • 3 Slotted Screwdriver Bits 4, 5.5, 7mm • 3 Pozidriv Bit Sockets PZ1, 2, 3 • 3 Phillips Bit Sockets, PH1, 2, 3

58 Piece 1/4" Square Drive Metric Socket Set

Ref	Contents
748255	<ul style="list-style-type: none"> • 1/4" SD Quick release ratchet • 13 1/4" SD Cold forged metric hexagon sockets 4, 4.5, 5, 5.5, 6, 7, 8, 9, 10, 11, 12, 13, 14mm • 10 1/4" SD Cold forged deep metric hexagon sockets 5, 5.5, 6, 7, 8, 9, 10, 11, 12, 13mm • 1/4" SD Wobble extension bar 50mm • 2 1/4" SD Extension bars 100mm and 150mm • 1/4" SD Flexible extension bar 150mm • 1/4" SD Sliding T handle • 1/4" SD Universal joint • 1/4" SD - 1/4" Hexagon drive bit holder • 1/4" SD Female - 3/8" SD Male drive adapter • 1/4" Hexagon drive ratcheting screwdriver • 4 1/4" Hexagon drive slotted screwdriver bits 4, 4.5, 6.5, 8mm • 3 1/4" Hexagon drive Phillips® screwdriver bits Ph1, 2, 3 • 3 1/4" Hexagon drive Pozidriv® screwdriver bits Pz1, 2, 3 • 6 1/4" Hexagon drive tamper proof Torx® screwdriver bits T10, 15, 20, 25, 30, 40 • 5 1/4" Hexagon drive metric hexagon screwdriver bits 2, 3, 4, 5, 6mm • 3 1/4" Hexagon drive AF hexagon screwdriver bits 1/8, 3/16, 1/4"

77 Piece 1/4" Square Drive Metric, AF and Torx Socket Set

Ref	Contents
748256	<ul style="list-style-type: none"> • 1/4" SD Quick release ratchet • 13 1/4" SD Cold forged metric hexagon sockets 4, 4.5, 5, 5.5, 6, 7, 8, 9, 10, 11, 12, 13, 14mm • 10 1/4" SD Cold forged deep metric hexagon sockets 5, 5.5, 6, 7, 8, 9, 10, 11, 12, 13mm • 9 1/4" SD Cold forged AF hexagon sockets 3/16, 7/32, 1/4, 9/32, 5/16, 11/32, 3/8, 7/16, 1/2" • 5 1/4" SD Cold forged deep AF hexagon sockets 3/16, 1/4, 5/16, 3/8, 1/2" • 6 1/4" SD Female Torx® sockets T4, 5, 6, 7, 8, 10 • 1/4" SD Wobble extension bar 50mm • 2 1/4" SD Extension bars 100mm and 150mm • 1/4" SD Flexible extension bar 150mm • 1/4" SD Sliding T handle • 1/4" SD Universal joint • 1/4" SD - 1/4" Hexagon drive bit holder • 1/4" SD Female - 3/8" SD Male drive adapter • 1/4" Hexagon drive ratcheting screwdriver • 4 1/4" Hexagon drive slotted screwdriver bits 4, 4.5, 6.5, 8mm • 3 1/4" Hexagon drive Phillips® screwdriver bits Ph1, 2, 3 • 3 1/4" Hexagon drive Pozidriv® screwdriver bits Pz1, 2, 3 • 6 1/4" Hexagon drive tamper proof Torx® screwdriver bits T10, 15, 20, 25, 30, 40 • 5 1/4" Hexagon drive metric hexagon screwdriver bits 2, 3, 4, 5, 6mm • 3 1/4" Hexagon drive AF hexagon screwdriver bits 1/8, 3/16, 1/4"





3/8" Square Drive Ratchets

Ref	Description
A45	Polypropylene handle – resistant to hydrocarbons, 72 Tooth mechanism- 5° minimum working arc, Thumb reversible
A46	Polypropylene handle – resistant to hydrocarbons, 72 Tooth mechanism- 5° minimum working arc, Lock-On design, Thumb reversible



3/8" SD Clutch Ratchet

Ref	Description
A77	Polypropylene handle – resistant to hydrocarbons, Roller bearing mechanism, Push-thru reversible mechanism, Thumb reversible



3/8" Square Drive Flexible Headed Ratchet

Ref	Description
AF45	72 Tooth high strength twin pawl mechanism, Polypropylene handle – resistant to hydrocarbons, Flexible head for increased access



3/8" SD Swivel Headed Reversible Ratchet

Ref	Description
AFS20	Polypropylene handle – resistant to hydrocarbons, 72 Tooth mechanism - 5° minimum working arc, Swivel head design for improved access



3/8" SD Sliding T Handle

Ref	Description
A70	Manufactured to DIN3122



3/8" SD Universal Joint

Ref	Description
A91	High strength design, Manufactured to DIN3123



3/8" SD Female – 1/2" SD Male Converter

Ref	Description
ASEP	Used to drive 1/2" accessories using a 3/8" input, Manufactured to DIN3123



1/2" SD Female – 3/8" SD Male Converter

Ref	Description
APES	Used to drive 3/8" accessories using a 1/2" input, Manufactured to DIN3123



Bit Holders

Ref.	[F] Hex AF	[M] Hex AF	Length mm
A1UBA	3/8"	1/4"	28



3 Piece 3/8" Square Drive Extension Bar Set

Ref	Description
708520	3 3/8" SD Extension bars 75mm, 150mm and 250mm

3/8" Square Drive Socket Sets



14 Piece 3/8" Square Drive Metric Socket Set

Ref	Contents
708110	14 3/8" SD Cold forged metric hexagon sockets 6, 7, 8, 9, 10, 11, 12, 13, 14, 15, 16, 17, 18, 19mm



15 Piece 3/8" Square Drive Deep Metric Socket Set

Ref	Contents
748262	15 3/8" SD Cold forged deep metric hexagon sockets 6, 7, 8, 9, 10, 11, 12, 13, 14, 15, 16, 17, 18, 19, 22mm



13 Piece 3/8" Square Drive AF Socket Set

Ref	Contents
708120	13 3/8" SD Cold forged AF hexagon sockets 1/4, 5/16, 11/32, 3/8, 7/16, 1/2, 9/16, 5/8, 11/16, 3/4, 13/16, 7/8, 1"



24 Piece 3/8" Square Drive Metric Socket Set

Ref	Contents
748263	<ul style="list-style-type: none"> • 3/8" SD Quick release ratchet • 19 3/8" SD Cold forged metric hexagon sockets 6, 7, 8, 9, 10, 11, 12, 13, 14, 15, 16, 17, 18, 19, 20, 21, 22, 23, 24mm • 2 3/8" SD Extension bars 75mm and 125mm • 3/8" SD Universal joint • 3/8" SD - 1/4" Hexagon drive bit holder



7 Piece 3/8" Square Drive Metric Ball Ended Bit Socket Set

Ref.	Contents
708130	7 Ball ended hexagon metric bit sockets 3, 4, 5, 6, 7, 8, 10mm



18 Piece 3/8" Square Drive AF Socket Set

Ref	Contents
748264	<ul style="list-style-type: none"> • 3/8" SD Quick release ratchet • 13 3/8" SD Cold forged AF hexagon sockets 1/4, 5/16, 11/32, 3/8, 7/16, 1/2, 9/16, 5/8, 11/16, 3/4, 13/16, 7/8, 1" • 3/8" SD Wobble extension bar 75mm • 3/8" SD Extension bar 150mm • 3/8" SD Universal joint • 3/8" SD - 1/4" Hexagon drive bit holder



8 Piece 3/8" Square Drive Flexible Metric Socket Set

Ref.	Contents
708140	8 Flexible sockets 10, 11, 12, 13, 14, 15, 17, 19mm



60 Piece 3/8" Square Drive Metric Socket Set

Ref	Contents
748261	<ul style="list-style-type: none"> • Quick release ratchet • 18 Cold forged metric hexagon sockets 6, 7, 8, 9, 10, 11, 12, 13, 14, 15, 16, 17, 18, 19, 20, 21, 22, 24mm • 10 Deep, cold forged metric hexagon sockets 8, 9, 10, 11, 12, 13, 14, 15, 17, 19mm • 75mm Extension bar • 250mm Extension bar / Sliding T handle • Universal joint • 2 Spark plug sockets 16, 21mm • 7 Hexagon bit sockets 3, 4, 5, 6, 7, 8, 10mm • 3 Slotted bit sockets 5.5, 7, 8mm • 9 Tamper proof torx bit sockets • 3 Pozidriv® bit sockets PZ1, 2, 3 • 3 Phillips® bit sockets PH1, 2, 3



83 Piece 3/8" Square Drive Metric Socket & Combination wrench Set

Ref	Contents
768261	<ul style="list-style-type: none"> • Quick release ratchet • 19 Metric hexagon sockets 6 - 24mm • 6 Deep metric hexagon sockets 10 - 19mm • 5 TX Star sockets T8, 10, 12, 14, 16 • 2 Extension bars 150mm and 250mm • Sliding T handle • Universal joint • 3/8" SD Female - 1/4" SD Male drive adapter • 3/8" SD Female - 1/2" SD Male drive adapter • Ratcheting Screwdriver with hi-torque handle • 31 Piece Insert Bit Set • 14 Metric combination wrenches 6, 7, 8, 9, 10, 11, 12, 13, 14, 15, 16, 17, 18, 19mm

88 Piece 3/8" Square Drive Metric, AF & Torx Socket Set

Ref	Contents
748267	<ul style="list-style-type: none"> • 3/8" SD Quick release ratchet • 19 3/8" SD Cold forged metric hexagon sockets 6, 7, 8, 9, 10, 11, 12, 13, 14, 15, 16, 17, 18, 19, 20, 21, 22, 23, 24mm • 11 3/8" SD Cold forged deep metric hexagon sockets 8, 9, 10, 11, 12, 13, 14, 15, 16, 17, 19mm • 13 3/8" SD Cold forged AF hexagon sockets 1/4, 5/16, 11/32, 3/8, 7/16, 1/2, 9/16, 5/8, 11/16, 3/4, 13/16, 7/8, 1" • 7 3/8" SD Cold forged deep AF hexagon sockets 5/16, 3/8, 7/16, 1/2, 9/16, 11/16, 3/4" • 5 3/8" SD Female Torx® sockets T8, 10, 12, 14, 16 • 3/8" SD Wobble extension bar 75mm • 2 3/8" SD Extension bars 150mm and 250mm • 3/8" SD Sliding T handle • 3/8" SD Universal joint • 3/8" SD - 1/4" Hexagon drive bit holder • 3/8" SD Female - 1/4" SD Male drive adapter • 3/8" SD Female - 1/2" SD Male drive adapter • 4 1/4" Hexagon drive slotted screwdriver bits 4, 4.5, 6.5, 8mm • 3 1/4" Hexagon drive Phillips screwdriver bits Ph1, 2, 3 • 3 1/4" Hexagon drive Pozidriv screwdriver bits Pz1, 2, 3 • 6 1/4" Hexagon drive tamper proof Torx screwdriver bits T10, 15, 20, 25, 30, 40 • 5 1/4" Hexagon drive metric hexagon screwdriver bits 2, 3, 4, 5, 6mm • 3 1/4" Hexagon drive AF hexagon screwdriver bits 1/8, 3/16, 1/4"



1/2" Square Drive Socketry



1/2" Square Drive Ratchet

Ref	Description
E74	Polypropylene handle – resistant to hydrocarbons, 72 Tooth mechanism- 5° minimum working arc, Thumb reversible



1/2" Square Drive Lock-On Ratchet

Ref	Description
E75	Polypropylene handle – resistant to hydrocarbons, 72 Tooth mechanism- 5° minimum working arc, Lock-On design, Thumb reversible



1/2" SD Clutch Ratchet

Ref	Description
E77	Polypropylene handle – resistant to hydrocarbons, Roller bearing mechanism, Push-thru reversible mechanism, Thumb reversible



1/2" Square Drive Flexi Head Ratchet

Ref	Description
EF74	72 Tooth high strength twin pawl mechanism, Polypropylene handle – resistant to hydrocarbons, Flexible head for increased access



1/2" SD Swivel Headed Reversible Ratchet

Ref	Description
EFS20	Polypropylene handle – resistant to hydrocarbons, 72 Tooth mechanism - 5° minimum working arc, Swivel head design for improved access



1/2" SD 600mm Swivel Handle

Ref	Description
E85	Polypropylene handle – resistant to hydrocarbons, 460mm long for exceptional leverage
E86	Polypropylene handle – resistant to hydrocarbons, 600mm long for exceptional leverage



1/2" SD Sliding T Handle

Ref	Description
E70	Manufactured to DIN3122



1/2" SD Universal Joint

Ref	Description
E91	High strength design, Manufactured to DIN3123

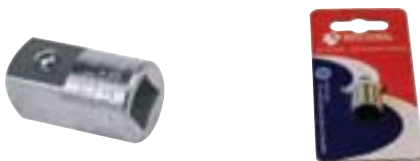

1/2" SD Female – 3/4" SD Male Converter

Ref	Description
ESHF	Used to drive 3/4" accessories using a 1/2" input, Manufactured to DIN3123

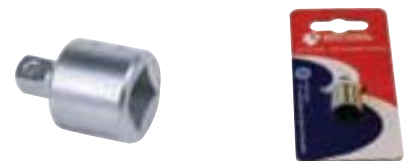

3/4" SD Female – 1/2" SD Male Converter

Ref	Description
EPHS	Used to drive 1/2" accessories using a 3/4" input, Manufactured to DIN3123





3 Piece 1/2" Square Drive Extension Bar Set

Ref	Contents
708530	3 1/2" SD Extension bars 75mm, 125mm and 250mm



15 Piece 1/2" Square Drive AF Socket Set

Ref	Contents
708230	15 1/2" SD Cold forged AF hexagon sockets 3/8, 7/16, 1/2, 9/16, 5/8, 11/16, 3/4, 13/16, 7/8, 15/16, 1, 1 1/16, 1 1/8, 1 3/16, 1 1/4"



10 Piece 1/2" Square Drive Metric Socket Set

Ref	Contents
708260	10 1/2" SD Cold forged metric hexagon sockets 10, 11, 12, 13, 14, 15, 16, 17, 18, 19mm



6 Piece 1/2" Square Drive Whitworth Socket Set

Ref	Contents
708270	6 1/2" SD Whitworth sockets 3/16, 1/4, 5/16, 3/8, 7/16, 1/2WWW



16 Piece 1/2" Square Drive Metric Socket Set

Ref	Contents
708220	25 1/2" SD Cold forged metric hexagon sockets 10, 11, 12, 13, 14, 15, 16, 17, 18, 19, 21, 22, 24, 27, 30, 32mm



1/2" Square Drive Socket Sets



7 Piece 1/2" Square Drive Hexagon Bit Socket Set

Ref.	Contents
708240	7 Hexagon bit sockets 6, 7, 8, 10, 12, 14, 17mm



14 Piece 1/2" Square Drive Deep Metric Socket Set

Ref	Contents
748275	14 1/2" SD Cold forged metric deep hexagon sockets 12, 13, 14, 15, 16, 17, 18, 19, 21, 22, 24, 27, 30, 32mm



12 Piece 1/2" Square Drive Metric Bit Socket Set

Ref.	Contents
748276	<ul style="list-style-type: none"> • 6 Metric bit sockets 4, 5, 6, 8, 10, 12mm • 6 Long reach metric bit sockets 4, 5, 6, 8, 10, 12mm



16 Piece 1/2" Square Drive Torx® Socket Set

Ref.	Contents
748277	<ul style="list-style-type: none"> • 9 Torx® bit sockets T20, 25, 27, 30, 40, 45, 50, 55, 60 • 7 Torx sockets E10, 12, 14, 16, 18, 20, 24



Counter Top socket stand
Ref. CTSOCKETSTAND



Socket stand
Ref. SOCKETSTAND



26 Piece 1/2" Square Drive Metric Socket Set

Ref	Contents
748271	<ul style="list-style-type: none"> • Ratchet • 3 Extension Bars 75, 125 & 250mm • Universal Joint • Sliding T Adapter • 2 Spark Plug Sockets 16 & 21mm • 18 Metric Sockets 10, 11, 12, 13, 14, 15, 16, 17, 18, 19, 20, 21, 22, 23, 24, 27, 30, 32mm



23 Piece 1/2" Square Drive AF Socket Set

Ref	Contents
748273	<ul style="list-style-type: none"> • 1/2" SD Quick release ratchet • 17 1/2" SD Cold forged AF hexagon sockets 3/8, 7/16, 1/2, 9/16, 19/32, 5/8, 21/32, 11/16, 3/4, 13/16, 7/8, 15/16, 1, 1 1/16, 1 1/8, 1 3/16, 1 1/4" • 1/2" SD Wobble extension bar 75mm • 2 1/2" SD Extension bars 150mm and 250mm • 1/2" SD Sliding T handle • 1/2" SD Universal joint



44 Piece 1/2" Square Drive Metric Socket Set

Ref	Contents
748272	<ul style="list-style-type: none"> • 1/2" SD Quick release ratchet • 25 1/2" SD Cold forged metric hexagon sockets 8, 9, 10, 11, 12, 13, 14, 15, 16, 17, 18, 19, 20, 21, 22, 23, 24, 25, 26, 27, 28, 29, 30, 32, 34mm • 11 1/2" SD Cold forged deep metric hexagon sockets 12, 13, 14, 15, 16, 17, 18, 19, 21, 22, 24mm • 1/2" SD Wobble extension bar 75mm • 2 1/2" SD Extension bars 125mm and 250mm • 1/2" SD Sliding T handle • 1/2" SD Universal joint • 1/2" SD Female - 3/8" SD Male drive adapter • 3/8" SD Female - 1/2" SD Male drive adapter



56 Piece 1/2" Square Drive Metric, AF & Torx Socket Set

Ref	Contents
748274	<ul style="list-style-type: none"> • 1/2" SD Quick release ratchet • 25 1/2" SD Cold forged metric hexagon sockets 8, 9, 10, 11, 12, 13, 14, 15, 16, 17, 18, 19, 20, 21, 22, 23, 24, 25, 26, 27, 28, 29, 30, 32, 34mm • 15 1/2" SD Cold forged AF hexagon sockets 3/8, 7/16, 1/2, 9/16, 5/8, 11/16, 3/4, 13/16, 7/8, 15/16, 1, 1 1/16, 1 1/8, 1 3/16, 1 1/4" • 8 1/2" SD Cold forged Torx® sockets T10, 11, 12, 14, 16, 18, 20, 24 • 1/2" SD Wobble extension bar 75mm • 2 1/2" SD Extension bars 125mm and 250mm • 1/2" SD Sliding T handle • 1/2" SD Universal joint • 1/2" SD Female - 3/8" SD Male drive adapter • 3/8" SD Female - 1/2" SD Male drive adapter

Mixed Drive Socket Sets



5 Piece 1/4" and 3/8" Square Drive Extension Bar Set

Ref	Description
708540	<ul style="list-style-type: none"> • 2 1/4" SD Extension bars 50mm and 100mm • 3 3/8" SD Extension bars 75mm, 150mm and 250mm



5 Piece 1/4" and 3/8" Square Drive Wobble Extension Bar Set

Ref.	Description
708550	<ul style="list-style-type: none"> • 2 Wobble Extension bars 50mm and 100mm • 3 Wobble Extension bars 75mm, 150mm and 250mm



13 Piece 1/4", 3/8" and 1/2" Square Drive Female Torx® Socket Set

Ref	Description
708430	<ul style="list-style-type: none"> • 5 1/4" SD Female Torx® sockets E4, 5, 6, 7, 8 • 4 3/8" SD Female Torx® sockets E10, 12, 14, 16 • 4 1/2" SD Female Torx® sockets E18, 20, 22, 24

71 Piece 1/4" and 3/8" Square Drive Metric Socket Set

Ref	Description
748293	<ul style="list-style-type: none"> • 1/4" SD Quick release ratchet • 13 1/4" SD Cold forged metric hexagon sockets 4, 4.5, 5, 5.5, 6, 7, 8, 9, 10, 11, 12, 13, 14mm • 9 1/4" SD Cold forged deep metric hexagon sockets 5, 6, 7, 8, 9, 10, 11, 12, 13mm • 5 1/4" SD Female Torx® sockets T4, 5, 6, 7, 8 • 2 1/4" SD Extension bars 50mm and 150mm • 1/4" SD Sliding T handle • 1/4" SD Universal joint • 1/4" SD – 1/4" Hexagon drive bit holder • 3/8" SD Quick release ratchet • 19 3/8" SD Cold forged metric hexagon sockets 6, 7, 8, 9, 10, 11, 12, 13, 14, 15, 16, 17, 18, 19, 20, 21, 22, 23, 24mm • 8 3/8" SD Cold forged deep metric hexagon sockets 13, 14, 15, 16, 17, 18, 19, 22mm • 4 3/8" SD Female Torx® sockets T10, 12, 14, 16 • 3 3/8" SD Extension bars 75, 125mm and 250mm • 3/8" SD Sliding T handle • 3/8" SD Universal joint • 3/8" SD – 1/4" Hexagon drive bit holder



14 Piece 1/4" and 3/8" Square Drive Torx® Bit Socket Set

Ref	Description
708410	<ul style="list-style-type: none"> • 10 1/4" SD Torx® bit sockets T6, 7, 8, 9, 10, 15, 20, 25, 27, 30 • 4 3/8" SD Torx® bit sockets T40, 45, 50, 55



9 Piece 1/4" and 3/8" Square Drive Hexagon Insert Bit Socket Set

Ref	Description
708420	<ul style="list-style-type: none"> • 4 1/4" SD Hexagon bit sockets 3, 4, 5, 6mm • 5 3/8" SD Hexagon bit sockets 7, 8, 9, 10, 12mm



110 Piece 1/2" and 1/4" Square Drive Metric Socket Set

Ref	Description
748291	<p>1/2" Square Drive</p> <ul style="list-style-type: none"> • Quick release ratchet • 17 Cold forged metric hexagon sockets 10, 11, 12, 13, 14, 15, 16, 17, 18, 19, 20, 21, 24, 27, 30, 32mm • 5 Deep, cold forged metric hexagon sockets 14, 15, 17, 19, 22mm • 8 Female Torx® sockets T10, 11, 12, 14, 16, 18, 20, 24 • 125mm Extension bar • 250mm Extension bar / Sliding T handle • Universal joint • 2 Spark plug sockets 16, 21mm • 5/16" Hexagon Bit Holder <p>1/4" Square Drive</p> <ul style="list-style-type: none"> • Quick release ratchet • 13 Cold forged metric hexagon sockets 4, 4.5, 5, 5.5, 6, 7, 8, 9, 10, 11, 12, 13, 14mm • 8 Deep, cold forged metric hexagon sockets 6, 7, 8, 9, 10, 11, 12, 13mm • 5 Female Torx® sockets T4, 5, 6, 7, 8 • 50mm Extension bar • 100mm Extension bar • Sliding T handle • Universal joint • Spinner handle • 7 Torx® bit sockets T8, 10, 15, 20, 25, 27, 30 • 3 Slotted screwdriver bits 4, 5.5, 6.5mm • 4 Hexagon bit sockets 3, 4, 5, 6mm • 2 Pozidriv® bit sockets PZ 1, 2 • 2 Phillips® bit sockets PH 1, 2 • 4 Hexagon Keys 1.27, 1.5, 2, 2.5mm • Hexagon Insert Bits • 5 Torx® insert bits T40, 45, 50, 55, 60 • 2 Phillips® insert bits PH3, 4 • 2 Pozidriv® insert bits PZ3, 4 • 7 Torx® bit sockets T8, 10, 15, 20, 25, 27, 30 • 3 Slotted insert bits 8, 10, 12mm • 5 Hexagon insert bits 7, 8, 10, 12, 14mm • 1/4" Hexagon / 1/4" SD adapter



3/4" Square Drive Socketry



3/4" Square Drive Swivel Handle

Ref	Description
H85	<ul style="list-style-type: none"> • 1m Long for exceptional leverage • Steel handle



3/4" Square Drive Ratchet

Ref	Description
H74	Lever reversible



3/4" Square Drive Sliding T Handle

Ref	Description
H70	Manufactured to DIN3122



21 Piece 3/4" Square Drive Metric Socket Set

Ref	Description
748289	<ul style="list-style-type: none"> • Ratchet • 3 Extension Bars 75, 125 & 250mm • Sliding T Handle • 16 Metric Hexagon Sockets 19, 21, 22, 23, 24, 26, 27, 29, 30, 32, 35, 36, 38, 41, 46, 50mm

Specification

Designed to exacting standards and manufactured from the highest quality alloy steel, Britool impact sockets are heat treated to ensure that they conform to the highest standards of reliability and durability.

Britool impact sockets are suitable for use with all air and power tools.

All Britool impact sockets incorporate Stress Relief Drive, increasing the maximum applicable torque and reducing fastener damage.

Manufactured to ISO 1174-2

WARNING!

Do not use chrome finished sockets on impact and power tools.



9 Piece 3/8" Square Drive Metric Impact Socket Set

Ref	Description
758200	9 3/8" SD Cold forged metric hexagon impact sockets 8, 9, 10, 11, 12, 13, 14, 17, 19mm



17 Piece 1/2" Square Drive Metric Impact Socket Set

Ref	Description
758300	<ul style="list-style-type: none"> • 16 1/2" SD Cold forged metric hexagon impact sockets 10, 11, 12, 13, 14, 15, 16, 17, 18, 19, 21, 22, 24, 27, 30, 32mm • 125mm Impact extension bar • Locking pins and rings



14 Piece 1/2" Square Drive Deep Metric Impact Socket Set

Ref	Description
758500	<ul style="list-style-type: none"> • 14 1/2" SD Cold forged deep metric hexagon impact sockets 10, 11, 12, 13, 14, 16, 17, 19, 21, 22, 24, 27, 30, 32mm • Locking pins and rings

Torque Wrenches



The torque wrench is an essential hand tool that is now fundamental in all garages and workshops.

The Britool torque wrench range has been carefully designed to provide a range of solutions to meet the needs of the torque-tightening user.

What is Torque ?

- Torque is a turning or twisting force, the result of a force applied at a given distance about a known centre
- It is recorded in units of force x distance

i.e. **Nm = Newtons (force) x metres (distance) or**

lbf/ft = lbf (force) x feet (distance) (1 Newton = 1kg m/s²)

Classic Mechanical Torque Wrenches

The Britool Classic torque wrench has won a reputation for reliability and quality established over 50 years. The unique mechanism has distinct advantages which ensure it remains a firm favourite with users worldwide.

Unique 3-phase Mechanism

A progressive torque build-up to the selected setting is easily detected by three clear signals:

- 1 **SIGHT** see the mechanism progressively move towards the point of break as the load is applied
- 2 **TOUCH** feel the point of torque
- 3 **SOUND** unmistakable **CLICK**
This makes it ideal for use in noisy environments

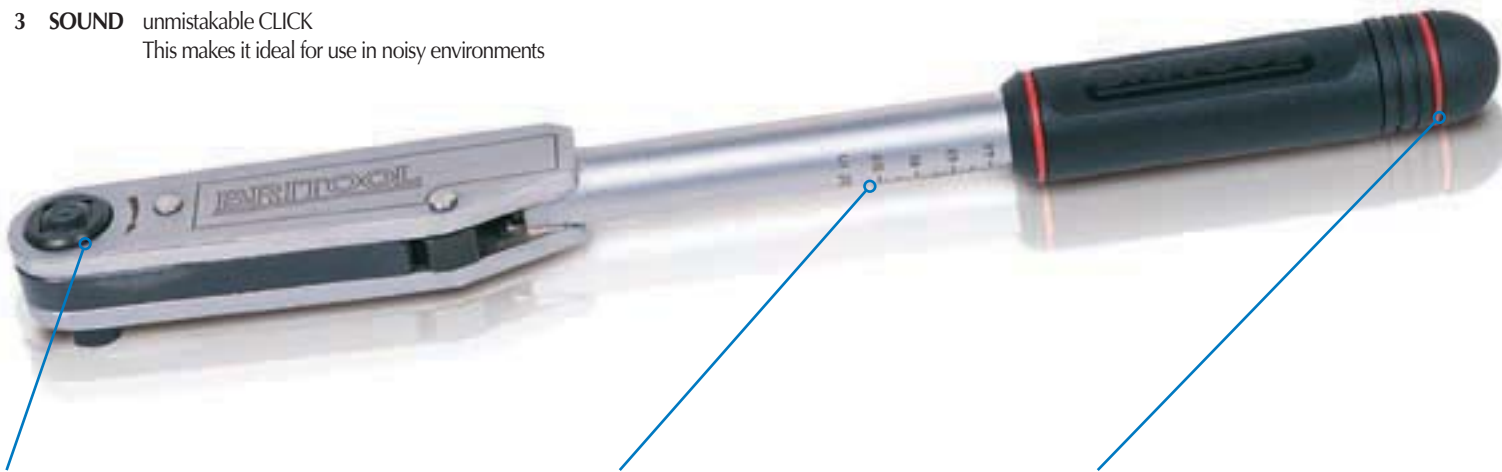
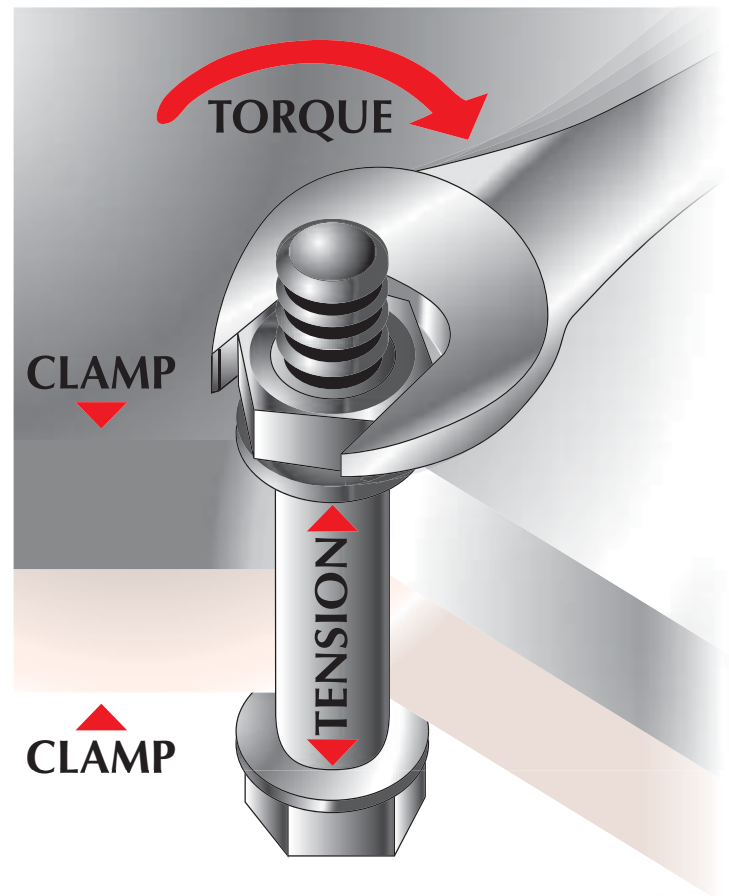

ACCESSIBILITY

Compact design ideal for restricted access

DURABILITY

Proven to be one of the most robust products in the market, the first choice for arduous conditions

ACCURACY

Exceeds requirements of ISO 6789

SCALE

Multiple scales – Nm, kg.m, lbf.in and lbf.ft are branded into steel tube, giving readability for the life of the product

FLEXIBILITY

Push-through square drive for left and right hand operation

SETTING

Retractable adjuster knob cannot be altered by accident

SERVICE

Fully repairable with dedicated service kits

Classic Mechanical Torque Wrench – Non-Length Dependant

Unlike most other torque wrenches, the mechanism pivots around the square drive. This gives the major advantage in that the torque wrench is not length dependant. As a result there is no variation to the application of the preset torque value, no matter where the handle is grasped.

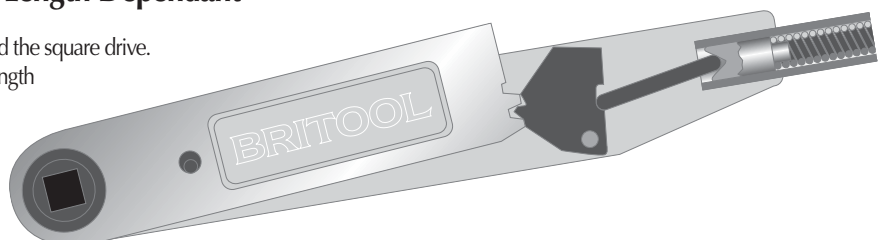

Classic Torque Wrench Ranges

Ref.	Square drive	N.m																
		2.5	5	10	20	33	50	70	100	135	200	225	300	330	480	720	940	
AVT100A	3/8																	
AVT300A																		
AVT600																		
EVT600A	1/2																	
EVT1200A																		
EVT2000A																		
EVT3000A																		
HVT5000	3/4																	
HVT7200																		
GVT8400	1																	

Scale Divisions

Series	N.m	Kg.m	lbf.in	lbf.ft
100	0.5	0.1	10.0	1.0
300	1.0	0.1	10.0	1.0
600	2.0	0.2	20.0	2.0
1200	5.0	1.0	50.0	2.0
2000	5.0	1.0	50.0	2.0
3000	10.0	1.0	100.0	10.0
5000	10.0	-	100.0	10.0
8400	10.0	-	-	10.0

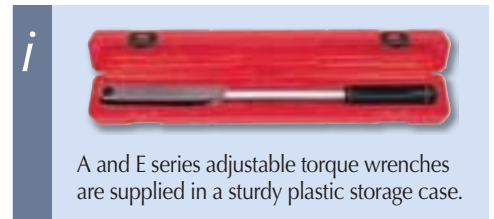

GVT8400

HVT7200

HVT5000



How To Read The Britool Torque Wrench Code

Square drive size inches	Regular type	Torque Wrench	Maximum lbf.in	Scale type
E	V	T	3000	A
Aero 3/8 Engineers 1/2 Heavy 3/4 Giant 1	Variable (regular, adjustable type)			A denotes a production change to the latest model

The example code in the blue band is for a 1/2" variable torque wrench, maximum 3000 lbf.in

Torque Measurement Conversion Chart

TO CONVERT FROM	TO CONVERT TO								
	mN.m millinewton-metre	cN.m centinewton-metre	N.m newton-metre	daN.m decanewton-metre	cm.kg centimetre-kg	m.kg metre-kg	in.oz inch-ounce	in.lb inch-pound	ft.lb foot-pound
1mN.m	1	0.1	0.001	0.0001	0.0102	0.000102	0.1418	0.00886	0.000738
1cN.m	10	1	0.01	0.001	0.102	0.00102	1.418	0.0886	0.00738
1N.m	1000	100	1	0.1	10.2	0.102	141.8	8.863	0.738
1daN.m	10000	1000	10	1	102	1.02	1418	88.63	7.38
1cm.kg	98	9.8	0.98	0.098	1	0.01	13.9	0.869	0.0724
1m.kg	9810	981	9.81	0.98	100	1	1390	86.90	7.24
1in.oz	7.05	0.705	0.00705	0.0007	0.072	0.0072	1	0.063	0.0052
1in.lb	112.8	11.28	0.1128	0.01128	1.152	0.0115	16	1	0.083
1ft.lb	1350	135	1.35	0.135	13.8	0.138	192	12	1



Classic Mechanical Torque Wrenches

- Certified accuracy to $\pm 4\%$

AVT100A



3/8" Classic

Ref.	Square drive	Torque range Nm	Length mm
AVT100A	3/8	2.5-11	318
AVT300A	3/8	5-33	422
AVT600	3/8	12-68	476

EVT3000A

EVT600A



1/2" Classic

Ref.	Square drive	Torque range Nm	Length mm
EVT600A	1/2	12-68	476
EVT1200A	1/2	25-135	546
EVT2000A	1/2	50-225	597
EVT3000A	1/2	70-330	825

- Exceeds the requirements of ISO 6789

HVT5000

GVT8400



3/4" & 1" Classic

Ref.	Square drive	Torque range Nm	Length mm
HVT5000	3/4	140-560	1130
HVT7200	3/4	200-810	1181
GVT8400	1	480-940	1397



Enclosed Mechanism Torque Wrenches

- Enclosed mechanism design
- Strong fine tooth ratchet mechanism - 5° minimum working arc
- Accurate to ±4%
- Complies with ISO 6789
- Positive lock - preventing accidental adjustment whilst in use



Dual scale - Foot Pounds and Newton Metres

Heavy duty reversible ratchet

Calibrated to meet the requirements of - ISO 6789

Adjustment lock - setting cannot be altered by accident

TORQUE RANGE				
Ref.	Drive	Capacity Nm Min. Max.	Length mm	
A50T	3/8" Ratchet	10 - 50	370	
E200T	1/2" Ratchet	40 - 200	495	
E340T	1/2" Ratchet	60 - 340	650	

Torque Calibration & Testing

- SI Metric and English imperial units
- Track and peak modes
- Accuracy +/-1% over operational range



CM1000

Checkmate Torque Testers

Ref.	Description	Range Nm	G	
CM40	Torque Tester	5-50	R	
CM400	Torque Tester	36-360	R	
CM1000	Torque Tester	110-1100	R	

Wrenches



Combination Wrenches

Britool combination wrenches feature Stress Relief Drive on the ring end. All open jaw ends feature a constant radius of curvature – reducing stress concentrations and jaw flexing. Both of these features enhance fastener grip and prolong both tool and fastener life. All Britool combination wrenches are manufactured to ISO 7738.

Britool combination wrenches are supplied in four different length variants – short, standard, long and extra long.

Britool combination wrenches are clearly marked with the wrench size on the open jaw head for ease of identification.



Open Jaw Wrenches

All open jaw ends feature a constant radius of curvature – reducing stress concentrations and flexing of the jaws.

Ring Wrenches

Britool Ring Wrenches are offset at 45° for ease of access and feature Stress Relief Drive.

Britool wrenches are manufactured to the latest ISO standards. All are forged from the highest quality steel and precision machined to exacting standards. They fulfil the needs of the professional engineer.

- Drop forged to ensure uniform grain structure, giving increased strength and reliability
- Heat treated in carefully controlled conditions to ensure optimum performance for every wrench
- Chrome plated for maximum corrosion protection

Britool's advanced Stress Relief Drive (SRD) is standard on all 12 point rings. This reduces fastener wear, assists in the removal of worn fasteners, and enables higher torque loads to be applied.

Britool's advanced ring configuration increases the contact area between the socket and the fastener, minimising stress and reducing the chance of fastener damage.

Because the load is applied to the flat of the fastener, rather than the corners – even if the fastener is already damaged – the drive is superior to a standard profile socket.

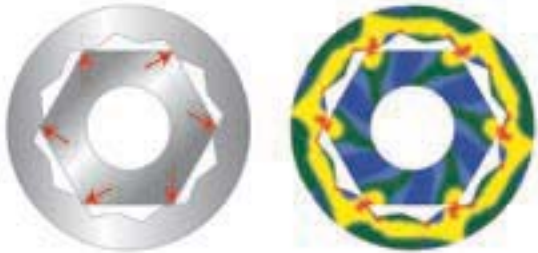

Conventional Profile

Corner point contact gives high stress areas – highlights show contact points on the corner of the fastener

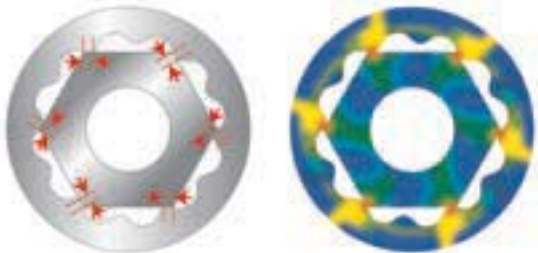

SRD Profile

Distributed surface loads relieves possible stress area – highlights show contact points away from the corner of the fastener

SAFETY MEASURES

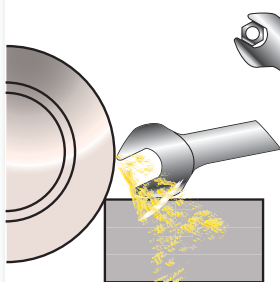

Never grind or alter the shape of the wrench

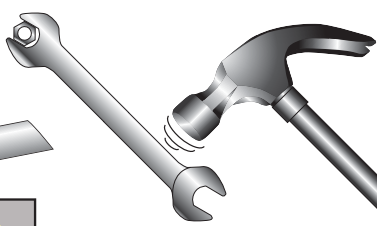

Never hammer or strike a wrench unless it is designed for this purpose



Never work with damaged or chipped tools

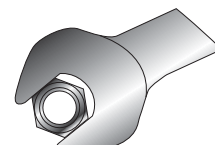

Always ensure there is a positive fit onto the fastener

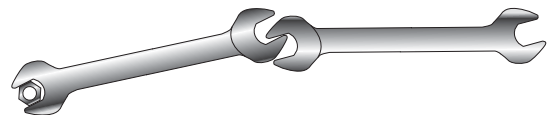

Do not extend length of wrench by locking two together



- 72 tooth mechanism for 5° minimum working arc
- Manufactured from chrome vanadium steel and heat treated for maximum strength
- Precision machined and hardened mechanism
- Flexi head design for ease of access

Flexible Metric Ratcheting Combination Wrench Set

Ref.	Description	Sizes
RRFJMSSET12	12 Piece Flexible	8, 9, 10, 11, 12, 13, 14, 15, 16, 17, 18, 19mm



- 72 tooth mechanism for 5° minimum working arc
- Manufactured from chrome vanadium steel and heat treated for maximum strength
- Precision machined and hardened mechanism
- Cranked reversible design

Metric Ratcheting Combination Wrench Set

Ref.	Description	Sizes
RRJMSET1	12 Piece	8, 9, 10, 11, 12, 13, 14, 15, 16, 17, 18, 19mm



- 72 tooth mechanism for 5° minimum working arc
- Manufactured from chrome vanadium steel and heat treated for maximum strength
- Precision machined and hardened mechanism

7 Piece AF Ratcheting Combination Wrench Set

Ref.	Description	Sizes
RRJSET7	7 Piece	3/8, 7/16, 1/2, 9/16, 5/8, 11/16, 3/4"



- Fine tooth mechanism gives a 5° minimum working arc
- Robust mechanism for high torque loads and long working life
- Heat treated chrome-vanadium construction for maximum strength and durability
- Chrome and nickel plating for maximum corrosion protection
- Cranked reversible design

Professional Stubby Combination Wrench Set

Ref.	Description	Sizes
RRJMSSET7	7 Piece	10, 12, 13, 14, 15, 17, 19mm



- 72 tooth mechanism for 5° minimum working arc
- Manufactured from chrome vanadium steel and heat treated for maximum strength
- Precision machined and hardened mechanism

Double Ended Ratcheting Wrench Set

Ref.	Description	Sizes
RRMSET5	5 Piece	8 x 10, 10 x 11, 12 x 13, 14 x 15, 17 x 19mm



- Advance profile allows each side of each ring to fit metric, torx and AF sizes
- Precision machined and hardened mechanism

2 Piece 4 Way Wrench Set - FITS 24 SIZES!

Ref.	Description	Sizes
RRMQSET2	2 Piece	<ul style="list-style-type: none"> • Fits metric sizes 8, 10, 11, 13, 14, 16, 17, 19mm • Fits AF sizes 5/16, 3/8, 7/16, 1/2, 9/16, 5/8, 11/16, 3/4" • Fits Torx sizes E10, 12, 14, 16, 18, 20, 22, 24



- Fine tooth mechanism gives a 5° minimum working arc
- Robust mechanism for high torque loads and long working life
- Heat treated chrome-vanadium construction for maximum strength and durability
- Chrome and nickel plating for maximum corrosion protection

4 Piece Professional TX Star Wrench Set

Ref	Description	Sizes
RRTSET4	4 Piece	E6 x E8, E10 x E12, E14 x E16, E20 x E24



- 72 tooth mechanism for 5° minimum working arc
- Manufactured from chrome vanadium steel and heat treated for maximum strength
- Precision machined and hardened mechanism
- Ratcheting Combination Wrench Set With Rapid Open Jaw Feature

Rapid open jaw design

Ref.	Description	Sizes
RRJMSET12F	12 Piece Rapid Jaw	8, 9, 10, 11, 12, 13, 14, 15, 16, 17, 18, 19



- 72 tooth mechanism for 5° minimum working arc
- Manufactured from chrome vanadium steel and heat treated for maximum strength
- Precision machined and hardened mechanism
- Flexi head design for ease of access

Flexi Head Ratcheting Combination Wrenches

Ref.	Size mm	Length mm
RRFJM8	8	140
RRFJM9	9	145
RRFJM10	10	160
RRFJM11	11	170
RRFJM12	12	175
RRFJM13	13	184
RRFJM14	14	190
RRFJM15	15	200
RRFJM16	16	215
RRFJM17	17	230
RRFJM18	18	238
RRFJM19	19	248



- 72 tooth mechanism for 5° minimum working arc
- Manufactured from chrome vanadium steel and heat treated for maximum strength
- Precision machined and hardened mechanism

Reversible Ratcheting Combination Wrenches

Ref.	Size mm	Length mm
RRJM8	8	135
RRJM9	9	140
RRJM10	10	158
RRJM11	11	166
RRJM12	12	170
RRJM13	13	178
RRJM14	14	187
RRJM15	15	198
RRJM16	16	212
RRJM17	17	230
RRJM18	18	238
RRJM19	19	247



- 72 tooth mechanism for 5° minimum working arc
- Manufactured from chrome vanadium steel and heat treated for maximum strength
- Precision machined and hardened mechanism

Stubby Ratcheting Combination Wrenches

Ref.	Size mm	Length mm
RRJSM10	10	95
RRJSM12	12	103
RRJSM13	13	106
RRJSM14	14	112
RRJSM15	15	116
RRJSM17	17	126
RRJSM19	19	130



- 72 tooth mechanism for 5° minimum working arc
- Manufactured from chrome vanadium steel and heat treated for maximum strength
- Precision machined and hardened mechanism

Double Ended Ratcheting Wrenches

Ref.	Size mm	Length mm
RRM810	8 x 10	128
RRM1011	10 x 11	149
RRM1213	12 x 13	170
RRM1415	14 x 15	190
RRM1719	17 x 19	230

Combination Wrenches



- Turns a ratcheting wrench into a low profile – quick release ratchet
- 1/4"SD x 10mm, 3/8"SD x 13mm, 1/2"SD x 19mm

3 Piece Quick Release Adapter Set

Ref	Description	Sizes
RRSD3	3 Piece Adapter Set	1/4"SD x 10mm, 3/8"SD x 13mm, 1/2"SD x 19mm



Combination Wrenches - Metric

Ref.	Size mm	Length mm
RJM6	6	109
RJM7	7	119
RJM8	8	129
RJM9	9	139
RJM10	10	149
RJM11	11	159
RJM12	12	169
RJM13	13	179
RJM14	14	189
RJM15	15	199
RJM16	16	209
RJM17	17	219
RJM18	18	229
RJM19	19	239
RJM20	20	249
RJM21	21	259
RJM22	22	269
RJM23	23	279
RJM24	24	289
RJM25	25	299
RJM26	26	309
RJM27	27	319
RJM28	28	329
RJM30	30	349
RJM32	32	269
RJM34	34	409
RJM36	36	439
RJM41	41	479
RJM46	46	549
RJM50	50	549
RJM55	55	609
RJM60	60	699
RJM65	65	699



Extra Long Combination Wrenches - Metric

Ref.	Size mm	Length mm
RJXM10	10	190
RJXM11	11	208
RJXM12	12	226
RJXM13	13	244
RJXM14	14	262
RJXM15	15	280
RJXM16	16	298
RJXM17	17	315
RJXM18	18	334
RJXM19	19	351



Combination Wrenches - AF

Ref.	Size in	Length mm
RJ250	1/4	109
RJ312	5/16	129
RJ344	11/32	139
RJ375	3/8	149
RJ437	7/16	159
RJ500	1/2	179
RJ562	9/16	189
RJ625	5/8	209
RJ687	11/16	219
RJ750	3/4	239
RJ812	13/16	259
RJ875	7/8	269
RJ937	15/16	289
RJ1000	1	299
RJ1062	1 1/16	319
RJ1125	1 1/8	339
RJ1250	1 1/4	369
RJ1312	1 5/16	409
RJ1375	1 3/8	409
RJ1437	1 7/16	439
RJ1500	1 1/2	439
RJ1625	1 5/8	479
RJ1687	1 11/16	479
RJ1750	1 3/4	549
RJ1812	1 13/16	549
RJ1875	1 7/8	549



Combination Wrenches - Whitworth

Ref.	Size in	Whit	BA	Length mm
RJ248	0.25		4	109
RJ324	0.32		2	129
RJ338	0.34	1/8		139
RJ413	0.41		0	159
RJ445	0.45	3/16		159
RJ525	0.53	1/4		179
RJ600	0.6	5/16		209
RJ710	0.71	3/8		219
RJ820	0.82	7/16		259
RJ920	0.92	1/2		289
RJ1010	1.01	9/16		299
RJ1100	1.1	5/8		319
RJ1200	1.2	11/16		369
RJ1300	1.3	3/4		409
RJ1480	1.48	7/8		439

RJMSET14/TC



RJXSET10/TC



RJMSET7L/TC



**Combination Wrench Sets
– In ABS Tool Control Trays**

Ref.	Description	Sizes
RJMSET14/TC	14 Piece Metric	6, 7, 8, 9, 10, 11, 12, 13, 14, 15, 16, 17, 18, 19mm
RJMSET7L/TC	7 Piece Metric	20, 21, 22, 24, 27, 30, 32mm
RJXSET10/TC	10 Piece Metric – Extra Long	10, 11, 12, 13, 14, 15, 16, 17, 18, 19mm



ND349K



Stubby Combination Wrenches

Ref.	Description	Sizes
RJSMSET7	7 Piece Metric	10, 12, 13, 14, 15, 17, 19mm

Combination Wrench Sets

Ref.	Description	Sizes
RJMSET8	8 Piece Metric	8, 10, 11, 12, 13, 14, 17, 19mm
RJMSET11	11 Piece Metric	10, 11, 12, 13, 14, 15, 16, 17, 18, 19, 21mm
ND360E	17 Piece Metric	7, 8, 9, 10, 11, 12, 13, 14, 15, 16, 17, 18, 19, 21, 22, 23, 24mm
RJSET8	8 Piece AF	3/8, 7/16, 1/2, 9/16, 5/8, 11/16, 3/4, 7/8in
ND243L	10 Piece AF	3/8, 7/16, 1/2, 9/16, 5/8, 11/16, 3/4, 13/16, 7/8, 15/16in
ND251D*	14 Piece AF	3/8, 7/16, 1/2, 9/16, 5/8, 11/16, 3/4, 13/16, 7/8, 15/16, 1, 1 1/16, 1 1/8, 1 1/4in
ND130A	7 Piece Whitworth	1/8, 3/16, 1/4, 5/16, 3/8, 7/16, 1/2W
ND150J	11 Piece Whitworth	1/8, 3/16, 1/4, 5/16, 3/8, 7/16, 1/2, 9/16, 5/8, 11/16, 3/4W

RJMSET8



RJMSET11



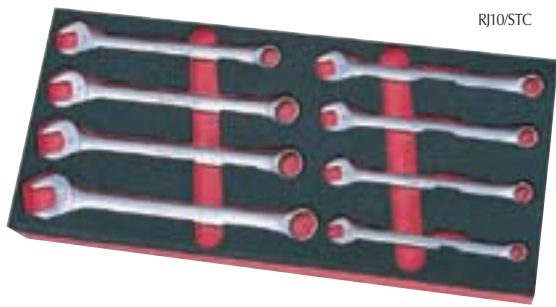

RJ10/STC



RJXMSET10

Wrench Sets - Hi-tech Foam

Ref.	Description	Sizes
RJ10/STC	8 Piece AF	1/4, 3/8, 7/16, 1/2, 9/16, 5/8, 11/16, 3/4in

Extra Long Combination Wrench Sets

Ref.	Description	Sizes
RJXMSET10	10 Piece Metric	10, 11, 12, 13, 14, 15, 16, 17, 18, 19mm



Open Jaw Wrenches

Open Jaw Wrenches - Metric

Ref.	Size mm	Length mm
2JM67	6 x 7	121
2JM78	7 x 8	138
2JM89	8 x 9	140
2JM1011	10 x 11	157
2JM1013	10 x 13	168
2JM1213	12 x 13	171
2JM1317	13 x 17	200
2JM1415	14 x 15	184
2JM1617	16 x 17	200
2JM1719	17 x 19	213

Open Jaw Wrenches - Metric

Ref.	Size mm	Length mm
2JM1819	18 x 19	213
2JM1922	19 x 22	245
2JM2022	20 x 22	245
2JM2123	21 x 23	245
2JM2224	22 x 24	259
2JM2427	24 x 27	286
2JM2430	24 x 30	313
2JM2730	27 x 30	315
2JM3032	30 x 32	321
2JM3236	32 x 36	368
2JM3641	36 x 41	343



Open Jaw Wrenches - AF

Ref.	Size in	Length mm
2J2531	1/4 x 5/16	121
2J3137	5/16 x 3/8	140
2J3743	3/8 x 7/16	157
2J4350	7/16 x 1/2	171
2J5056	1/2 x 9/16	184
2J5662	9/16 x 5/8	184
2J5668	9/16 x 11/16	200
2J6268	5/8 x 11/16	200
2J6275	5/8 x 3/4	213
2J6875	11/16 x 3/4	213
2J7587	3/4 x 7/8	245
2J8187	13/16 x 7/8	245
2J8193	13/16 x 15/16	245
2J93100	15/16 x 1	259
2J93112	15/16 x 1 1/8	285
2J106112	1 1/16 x 1 1/8	315
2J106125	1 1/16 x 1 1/4	317
2J125143	1 1/4 x 1 7/16	330
2J131150	1 5/16 x 1 1/2	330
2J162181	1 5/8 x 1 13/16	432
2J168187	1 11/16 x 1 7/8	432



Open Jaw Wrenches - Whitworth

Ref.	Size in	Whit	Length mm
2J3344	0.34 x 0.45	1/8 x 3/16	157
2J4452	0.45 x 0.53	3/16 x 1/4	171
2J5260	0.53 x 0.60	1/4 x 5/16	184
2J6071	0.60 x 0.71	5/16 x 3/8	200
2J7182	0.71 x 0.82	3/8 x 7/16	213
2J8292	0.82 x 0.92	7/16 x 1/2	245
2J92101	0.92 x 1.01	1/2 x 9/16	259
2J101110	1.01 x 1.10	1/2 x 5/8	283
2J101120	1.01 x 1.20	9/16 x 11/16	322
2J110120	1.10 x 1.20	5/8 x 11/16	317
2J120130	1.20 x 1.30	11/16 x 3/4	321
2J130148	1.30 x 1.48	3/4 x 7/8	330
2J148167	1.48 x 1.67	7/8 x 1	384
2J186205	1.86 x 2.05	1 1/8 x 1 1/4	467



Midget Open Jaw Wrenches - BA

Ref.	Size in	BA	Length mm
5J1013	0.10 x 0.13	11 x 9	70
5J1115	0.12 x 0.15	10 x 8	70
5J1722	0.17 x 0.22	7 x 5	80
5J1924	0.19 x 0.25	6 x 4	80
5J2432	0.25 x 0.32	4 x 2	80
5J2836	0.28 x 0.37	3 x 1	90
5J3241	0.32 x 0.41	2 x 0	100



*Supplied in red PVC wallet

Midget Open Jaw Wrench Sets

Ref.	Description	Sizes
NB108T	6 Piece BA	11 x 9, 10 x 8, 7 x 5, 6 x 4, 3 x 1, 2 x 0BA

Open Jaw Wrench Sets

Ref.	Description	Sizes
NB351G	11 piece Metric	6 x 7, 8 x 9, 10 x 11, 12 x 13, 14 x 15, 16 x 17, 18 x 19, 20 x 22, 21 x 23, 24 x 26 & 27 x 30mm
NB227D*	6 piece AF	5/16 x 3/8, 7/16 x 1/2, 9/16 x 5/8, 11/16 x 3/4, 13/16 x 7/8, 15/16 x 1in
NB231E	7 piece AF	5/16 x 3/8, 3/8 x 7/16, 7/16 x 1/2, 1/2 x 9/16, 9/16 x 5/8, 5/8 x 11/16, 11/16 x 3/4in
NB250P	10 piece AF	1/4 x 5/16, 5/16 x 3/8, 3/8 x 7/16, 7/16 x 1/2, 1/2 x 9/16, 9/16 x 5/8, 5/8 x 11/16, 11/16 x 3/4, 3/4 x 7/8, 15/16 x 1in
NB131R	7 piece Whitworth	1/8 x 3/16, 3/16 x 1/4, 1/4 x 5/16, 5/16 x 3/8, 3/8 x 7/16, 7/16 x 1/2, 1/2 x 9/16W
NB141C	9 piece Whitworth	1/8 x 3/16, 3/16 x 1/4, 1/4 x 5/16, 5/16 x 3/8, 3/8 x 7/16, 7/16 x 1/2, 1/2 x 9/16, 9/16 x 5/8, 5/8 x 11/16W



Open Jaw Wrench Sets in ABS Tool Control Trays

Ref.	Description	Sizes
2JMS8/TC	8 Piece Metric	6, 7, 8, 9, 10, 11, 12, 13, 14, 15, 16, 17, 18, 19mm

Ring Wrenches



Ring Wrenches - Metric

Ref.	Size mm	Length mm
9RBM67	6 x 7	168
9RBM89	8 x 9	183
9RBM1011	10 x 11	198
9RBM1213	12 x 13	217
9RBM1415	14 x 15	239
9RBM1617	16 x 17	260
9RBM1819	18 x 19	292



Ring Wrench Sets

Ref.	Description	Sizes
NC381T	7 Piece Metric	6 x 7, 8 x 9, 10 x 11, 12 x 13, 14 x 15, 16 x 17, 18 x 19mm

Ring Wrench Sets in ABS Tool Control Trays

Ref.	Description	Sizes
RRBMSET7/TC	7 Piece Metric	6x7, 8x9, 10x11, 12x13, 14x15, 16x17, 18x19mm



5 Piece Flare Nut Wrench Set

Ref.	Description	Sizes
FNSET5	5 Piece metric	5 Piece Flare Nut Wrench Set • Heat treated Chrome Vanadium construction for maximum strength • Chrome and Nickel plated for corrosion resistance • Contains sizes 7x9, 8x10, 11x13, 12x14, 17x19mm



Extra Long Ring Wrench Set

Ref.	Description	Sizes
RRLMSET3	3 Piece Metric	10x12, 13x14, 17x19

Ratcheting Ring Wrenches



Offset Ratcheting Wrenches - Metric

Ref.	Size mm	Length mm
RBOM78	7 x 8	109
RBOM910	9 x 10	138
RBOM1112	11 x 12	168
RBOM1314	13 x 14	168
RBOM1517	15 x 17	200
RBOM1921	19 x 21	227



Flat Ratcheting Wrenches - Metric

Ref.	Size mm	Length mm
RBB78	7 x 8	108
RBB910	9 x 10	140
RBB1112	11 x 12	171
RBB1314	13 x 14	171
RBB1517	15 x 17	203
RBB1618	16 x 18	203
RBB1921	19 x 21	235

Offset Ratcheting Wrenches - AF

Ref.	Size in	Length mm
RBO2531	1/4 x 5/16	109
RBO3743	3/8 x 7/16	138
RBO5056	1/2 x 9/16	168
RBO6268	5/8 x 11/16	168
RBO7587	3/4 x 7/8	227

Flat Ratcheting Wrenches - AF

Ref.	Size in	Length mm
RBB2531	1/4 x 5/16	108
RBB3743	3/8 x 7/16	140
RBB4350	7/16 x 1/2	171
RBB5056	1/2 x 9/16	171
RBB5662	9/16 x 5/8	203
RBB6268	5/8 x 11/16	203
RBB7587	3/4 x 7/8	235



Ratcheting Box Wrench Set

Ref.	Description	Sizes
RRMSET5	5 Piece Double Ended Ratcheting Wrench Set	8 x 10, 10 x 11, 12 x 13, 14 x 15, 17 x 19

Ratcheting Ring Wrench Sets

Ref.	Description	Sizes
RBOMSET	5 Piece Metric Ratcheting Offset	7 x 8, 9 x 10, 11 x 12, 15 x 17, 19 x 21mm
RBOSET	5 Piece AF Ratcheting Offset	1/4 x 5/16, 3/8 x 7/16, 1/2 x 9/16, 5/8 x 11/16, 3/4 x 7/8in

Miscellaneous Wrenches



'C' Hook Wrenches

Ref.	Size mm	Length mm
3150	19-51	165
3151	32-76	216
3152	51-121	267



Adjustable Wrenches - Chrome

Ref.	Jaw Opening (max) mm	Length mm
306C	19	152
308C	26	203
310C	30	254
312C	34	305
315C	42	381
318C	53	457



- Monoblock cast iron handle with I beam construction for strength and rigidity under load
- Handle and moving jaw are forged from high quality steel – heat treated to ensure maximum strength and wear resistance

Heavy Duty Pipe Wrenches

Ref	Length mm	Max Jaw Capacity mm
PW200	200	34
PW250	250	49
PW300	300	60
PW350	350	60
PW450	450	76



- Designed for scaffolding and steel work applications
- Heavy duty 32 tooth ratchet mechanism
- Zinc plated
- Stress relief drive on all socket heads
- Double sided mechanism gives two sizes per wrench

Ratcheting Podger Wrenches

Ref.	Description
RRPM1719	17 x 19
RRPM1921	19 x 21
RRPM2427	24 x 27

Screwdrivers & Insert Bits



Screwdrivers Technical Information

The performance of Britool screwdrivers exceeds ISO standards. This comprehensive range gives outstanding performance, providing optimum torque with a minimum of user fatigue.

Range

Britool screwdrivers are available with a full range of tips including long reach versions.

Screwdriver Blades

All Britool screwdriver blades have shot blasted tips to give increased grip—ensuring positive fastener location, and reducing slippage and possible damage or injury.

Heat treatment gives the correct balance of hardening and tempering—for optimum hardness without being brittle.

Blades designed to fit large fasteners incorporate a hexagon bolster, allowing a wrench to be used if extra torque is required.

Screwdriver Handles

Britool screwdriver handles are ergonomically designed with a two piece construction combining comfort in use with durability. A soft, textured rubber grip allows maximum torque to be applied without discomfort.

The tough bi-material handle is moulded directly onto the flanged blade, preventing the blade from twisting or pulling out of the handle.

- Colour coded for easy identification
- Textured finish ensures a firm grip even when greasy
- Large diameter handle gives a positive grip when applying high torque loads
- Small diameter area aids accurate location and fast screw turning
- Holed handle allows easy and safe storage



Engineers Screwdrivers



Flared Tip

Ref.	Length mm	Tip width mm
SM100/5.5	100	5.5
SM125/6.5	125	6.5
SM150/6.5	150	6.5
SM150/8	150	8.0
SM250/8	250	8.0
SM200/10	200	10.0
SM250/12	250	12.0

Torx

Ref.	Length mm	Tip
SM75T10	75	T10
SM75T15	75	T15
SM100T20	100	T20
SM100T25	100	T25
SM100T27	100	T27
SM125T30	125	T30
SM125T40	125	T40

Tamper Proof Torx

Ref.	Length mm	Tip
SM75TPT10	75	T10
SM75TPT15	75	T15
SM100TPT20	100	T20
SM100TPT25	100	T25
SM100TPT27	100	T27
SM125TPT30	125	T30
SM125TPT40	125	T40



Pozidriv

Ref.	Length mm	Tip
SM75PZ0	75	PZ0
SM75PZ1	75	PZ1
SM100PZ1	100	PZ1
SM125PZ2	125	PZ2
SM150PZ3	150	PZ3
SM200PZ4	200	PZ4



Stubby Pozidriv

Ref.	Length mm	Tip
SM30PZ1	30	PZ1
SM30PZ2	30	PZ2

Electricians Screwdrivers



Parallel Tip

Ref.	Length mm	Tip width mm
SE50/2.5	50	2.5
SE50/3	50	3.0
SE75/3.5	75	3.5
SE100/3.5	100	3.5
SE100/4	100	4.0
SE150/4	150	4.0
SE150/5.5	150	5.5
SE175/6.5	175	6.5
SE250/5	250	5.0



Phillips

Ref.	Length mm	Tip
SE50PH00	50	PH00
SE75PH0	75	PH0
SE75PH1	75	PH1
SE100PH1	100	PH1
SE125PH2	125	PH2
SE150PH3	150	PH3
SE200PH4	200	PH4



Insulated Parallel Tip

Ref.	Length mm	Tip width mm
SES50/2.5	50	2.5
SES100/3.5	100	3.5
SES150/4	150	4.0
SES175/5.5	175	5.5



Insulated Phillips

Ref.	Length mm	Tip
SES50PH00	50	PH00
SES75PH0	75	PH0
SES100PH1	100	PH1
SES125PH2	125	PH2



Stubby Parallel Tip

Ref.	Length mm	Tip width mm
SE30/4	30	4.0
SE30/5.5	30	5.5
SE30/6.5	30	6.5



Stubby Phillips

Ref.	Length mm	Tip
SE30PH1	30	PH1
SE30PH2	30	PH2





Screwdriver Sets		
Ref.	Description	Sizes
SDS5	5 Piece Flared & Parallel Tip	Flared Tip: 6.5, 8mm Parallel Tip: 3.5, 4, 5.5mm
SDS6	6 Piece Pozidriv, Flared & Parallel Tip	Flared Tip: 5.5, 6.5, 8mm Parallel Tip: 3.5mm Pozidriv: PZ1, PZ2
SDS7	7 Piece Pozidriv, Flared & Parallel Tip	Flared Tip: 5.5, 6.5, 8mm Parallel Tip: 3.5, 4mm Pozidriv: PZ1, PZ2

Micro Screwdriver Sets		
Ref.	Description	Sizes
SL4/S	4 Piece Torx Micro Set	T6, 7, 8, 9
SL6/S	6 Piece Slotted / Phillips Micro set	Slotted: 2, 2.5, 3 Phillips: PH000, 00, 0
SL8/S	9 Piece Interchangeable Tip Micro Set	Slotted: 1, 1.2, 1.5, 1.8, 2, 2.5mm Phillips: PH000, PH00

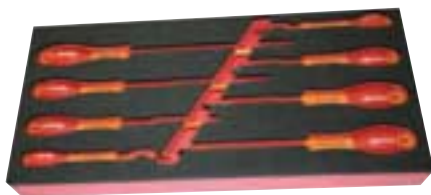

SDS8/TC



SDRIV1



SDRIV3



SDS9/TC



SDRIV4



SDRIV2



SDS11



SDRIV6



SDS7/2TC

Screwdriver Sets - Hi-tech Foam		
Ref.	Description	Sizes
SDS7/2TC	7 Piece Torx Set	Torx: T10, 15, 20, 25, 27, 30, 40
SDS8/TC	8 Piece Insulated Screwdriver Set	Insulated Parallel Tip: 2.5, 3.5, 4, 5.5mm Insulated Phillips Tip: PH00, PH0, PH1, PH2
SDS9/TC	9 Piece Phillips, Flared & Parallel Tip	Flared Tip: 6.5, 8. Parallel Tip: 3.5, 4, 5.5 4mm Stubby, Phillips: PH1, PH2 PH1 Stubby
SDS11	11 Piece Pozidriv, Flared & Parallel Tip	Flared Tip: 5.5, 6.5, 8. Parallel Tip: 3.5, 4, 6.5mm Stubby, Pozidriv: PZ0, PZ1, PZ2, PH3, PZ2 Stubby

Screwdriver Sets		
Ref.	Description	Sizes
SDRIV1	8 Piece Flared & Pozidriv Set Tip	Flared Tip :3.5, 4, 5.5, 6.5, 8 Pozidriv PZ0, PZ1, PZ2
SDRIV2	7 Piece Torx Screwdriver Set	Torx T10, T15, T20, T25, T27, T30, T40
SDRIV3	8 Piece Insulated Screwdriver Set	Insulated Parallel Tip : 2.5, 3.5, 4, 5.5 Phillips PH00, PH0, PH1, PH2
SDRIV4	8 Piece Flared & Phillips Screwdriver Set Insulated	Flared Tip :3.5, 4, 5.5, 6.5, 8 Pozidriv PH0, PH1, PH2
SDRIV5	7 Piece Tamper Proof Torx Screwdriver Set	Tamper Proof Torx:T10, T15, T20, T25, T27, T30, T40
SDRIV6	7 Piece Stubby Screwdriver Set	Slotted Tip: 4, 5.5, 6.5 Philips PH1, PH2 Pozidriv PZ1, 2

Ratcheting Screwdrivers



- Robust gearless mechanism – gives less than 1° minimum working arc
- Negligible reverse torque
- Magnetic bit retention
- Complete with bits: Pozidriv 1, 2, Phillips 1, 2 Slotted 4 & 6.5mm

Gearless Ratcheting Screwdrivers

Ref.	Description	Insert Bits	Length mm
BCSD1	Gearless ratcheting screwdriver	Phillips® PH1, 2 Pozidriv® PZ1, 2 Slotted 4, 6.5mm	225
BCSD2	Stubby gearless ratcheting screwdriver	Phillips® PH1, 2 Pozidriv® PZ1, 2 Slotted 4, 6.5mm	115
BCSD3	Long reach gearless ratcheting screwdriver	Phillips® PH1, 2 Pozidriv® PZ1, 2 Slotted 4, 6.5mm	310



Professional 35 Piece Ratcheting Screwdriver Set

Ref	Contents
BRSDSET1	<ul style="list-style-type: none"> • Fine tooth ratcheting screwdriver handle • 1/4" hexagon screwdriver blades - 150mm, 250mm • 1/4" square drive screwdriver blade - 250mm • 1/4" flexible screwdriver blade - 290mm • Hexagon bits: 3,4,5,6,7 & 8mm • Slotted bits: 4,5,5 & 7mm • Pozidriv® bits: #1,2 & 3 • Phillips® bits: #1,2 & 3 • Torx® bits: TX10,15,20,25,27,30 & 40 • Tamperproof Torx® bits: TTX10,15,20,25,27,30 & 40 • 1/4" hex - 1/4" square drive adaptor



- Handle can be adjusted to give an ergonomic pistol grip design allowing much higher torque loads to be applied
- Adjustable grip ratcheting screwdriver with 1/4" hexagon drive and interchangeable blade
- Cartridge style 6 bit holder
- Fine tooth high load reversible ratchet mechanism

Adjustable Grip Ratcheting Screwdriver

Ref	Insert Bits
BRSDF1	Phillips® Tip: Ph1, 2, Pozidriv® Tip: Pz1, 2 Slotted: 4, 6.5mm



- Fine tooth, high load reversible mechanism
- Soft touch ergonomic handle
- Soft eject, integral bit holder
- Complete with six S2 alloy steel bits

Professional Ratcheting Screwdriver

Ref	Insert Bits
BRSD2	Phillips® Tip: Ph1, 2, Pozidriv® Tip: Pz1, 2 Slotted: 4, 6.5mm



18 Piece Stubby Ratcheting Screwdriver Set

Ref	Contents
BRSDSET2	<ul style="list-style-type: none"> • Fine tooth stubby ratcheting screwdriver handle • 50mm 1/4" hexagon drive screwdriver blade • 150mm 1/4" square drive flexible screwdriver blade • 5 1/4" square drive sockets 4, 4.5, 5, 5.5, 6mm • 1/4" Hexagon (female) / 1/4" square drive adapter (female) • 9 1/4" square drive S2 steel insert bits • 2 Slotted bits: 4, 6.5mm • 3 Pozidriv bits; Pz1, 2, 3 • 3 Phillips bits; Ph1, 2, 3 • 1/4" Hexagon (male) / 1/4" square drive adapter (male)



31 Piece Multi-Pattern Bit Set

Ref	Contents
BBS31	<ul style="list-style-type: none"> • Locking bit holder • Slotted bits: 3.5,4.5,5.5,6.5 & 8mm • Phillips® bits: Ph1,2(x2) & 3 • Pozidriv® bits: Pz1,2(x2) & 3 • Hexagon bits: 2,3,4,5,6,7 & 8mm • Tamperproof Torx® bits: 9,10,15,20,25,27,30 & 40mm • Robertson® square bits: #1 & 2



109 Piece Multi-Pattern Bit Set & Driver

Ref	Contents
BBS109	<ul style="list-style-type: none"> • Multi-bit, quick release bit driver • Flexible extension • Drill bit adaptor • 1/2" hex - 1/4" female square adaptor • 1/4" hex - 1/4" male adaptor • Hook adaptor • Phillips® bits: Ph0-4 + 4 spares • Pozidriv® bits: Pz0-4 + 4 spares • Slotted bits • Robertson® square bits: #0-4 • Electrical security bits: #1-3 • Torx® bits: TX5 - TX50 • Tamperproof Torx® bits: TX6 - 40 • Hex bits: 1.5-8mm • Security hex bits: 1.5-8mm & 5/64 - 5/32" • Spline bits: SP4 - 8 • Torq-Set bits: #1/4 - 4 • Tri-wing bits: TW1 - 5 • Snake eye bits: 4-12

Hexagon Insert Bits

Ref.	Size AF	Hex Drive	Length mm
1USB093	3/32"	1/4"	25
1USB125	1/8"	1/4"	25
1USB156	5/32"	1/4"	25
1USB187	3/16"	1/4"	25
1USB250	1/4"	1/4"	25
1USB2M	2 mm	1/4"	25
1USB25M	2.5 mm	1/4"	25
1USB3M	3 mm	1/4"	25
1USB4M	4 mm	1/4"	25
1USB5M	5 mm	1/4"	25
1USB6M	6 mm	1/4"	25
2USB187	3/16"	5/16"	30
2USB218	7/16"	5/16"	30
2USB250	1/4"	5/16"	30
2USB312	5/16"	5/16"	30
2USB5M	5 mm	5/16"	30
2USB6M	6 mm	5/16"	30
2USB8M	8 mm	5/16"	30
3USB375	3/8"	14 mm	40
3USB500	1/2"	14 mm	40
3USB562	9/16"	14 mm	40
3USB10M	10 mm	14 mm	40
3USB12M	12 mm	14 mm	40
3USB14M	14 mm	14 mm	40

Slotted Insert Bits

Ref.	Point Width	Point Thickness	Hex Drive
1USS4T	4	0.57	1/4"
1USS45T	4.5	0.65	1/4"
1USS55T	5.5	0.81	1/4"
1USS65T	6.5	0.98	1/4"
1USS8T	8	1.63	1/4"

Pozidriv Insert Bits

Ref.	Tip	Hex Drive	Length mm
1UPZD0	PZ0	1/4"	25
1UPZD1T	PZ1	1/4"	25
1UPZD2T	PZ2	1/4"	25
1UPZD3T	PZ3	1/4"	25
1UPZD4	PZ4	1/4"	25
2UPZD1	PZ1	5/16"	32
2UPZD2	PZ2	5/16"	32
2UPZD3	PZ3	5/16"	32
2UPZD4	PZ4	5/16"	32

Phillips Insert Bits

Ref.	Tip	Hex Drive	Length mm
1UPHD1T	PH1	1/4"	25
1UPHD2T	PH2	1/4"	25
1UPHD3T	PH3	1/4"	25
1UPHD4	PH4	1/4"	25

Magnetic Bit Holder

Ref.	[F] Hex AF	[M] Hex AF	Length mm
1BHM	1/4"	1/4"	50

Long Reach Slotted Screw Insert Bits

Ref.	Point Width	Point Thickness	Hex Drive
2USS5	5.5	0.87	5/16"
2USS6	6.0	1.07	5/16"
2USS7	7.0	1.24	5/16"

Bit Holders

Ref.	[F] Hex AF	[M] Hex AF	Length mm
D1UBA	1/4"	1/4"	22
A1UBA	3/8"	1/4"	28

Torx Insert Bits

Ref.	Tip	Hex Drive	Length mm
1UTX6	T x 6	1/4"	25
1UTX7	T x 7	1/4"	25
1UTX8	T x 8	1/4"	25
1UTX9	T x 9	1/4"	25
1UTX10	T x 10	1/4"	25
1UTX15	T x 15	1/4"	25
1UTX20	T x 20	1/4"	25
1UTX25	T x 25	1/4"	25
1UTX27	T x 27	1/4"	27
1UTX30	T x 30	1/4"	30
1UTX40	T x 40	1/4"	40
2UTX25	T x 25	5/16"	35
2UTX30	T x 30	5/16"	35
2UTX40	T x 40	5/16"	35
2UTX45	T x 45	5/16"	35
2UTX50	T x 50	5/16"	35
2UTX55	T x 55	5/16"	35



Security Torx Insert Bits

Ref.	Tip	Hex Drive	Length mm
1UTX10S	T x 10	1/4"	25
1UTX15S	T x 15	1/4"	25
1UTX20S	T x 20	1/4"	25
1UTX25S	T x 25	1/4"	25
1UTX27S	T x 27	1/4"	25
1UTX30S	T x 30	1/4"	25
1UTX40S	T x 40	1/4"	25



Ball End Power Keys - Metric

Ref.	Hex Size mm	Length mm
HPKB4	4	183
HPKB5	5	183
HPKB6	6	240
HPKB8	8	240
HPKB10	10	240



Power Keys - Metric

Ref.	Hex Size mm	Length mm
HPK2	2	126
HPK2.5	2.5	126
HPK3	3	126
HPK4	4	183
HPK5	5	183
HPK6	6	240
HPK8	8	240
HPK10	10	240

Power Keys - Torx

Ref.	Tip	Length mm
TPK10	T10	126
TPK15	T15	126
TPK20	T20	126
TPK25	T25	133
TPK27	T27	133
TPK30	T30	190
TPK40	T40	190

Hexagon & Power Key Sets

Ball End



Standard



Hexagon Key Sets - Plastic Clip

Ref.	Description
HKM9/C	9 Piece Metric Key Set
HK9/C	9 Piece AF Key Set
HKMB9/C	9 Piece Metric Ball End Hexagon Key Set
HKB9/C	9 Piece AF Ball End Hexagon Key Set
HKML9/C	9 Piece Metric Long Reach Hexagon Key Set
HL9/C	9 Piece AF Long Reach Hexagon Key Set



TPK8/TC

Power Key Sets

Ref.	Contents
HPKM6/S	6 Piece Metric Power Key Set
TPK6/S	6 Piece Torx Power Key Set

Power Key Sets - Hi-tech Foam

Ref.	Contents
HPKM8/TC	2, 2.5, 3, 4, 5, 6, 8, 10mm Hexagon Power Keys
TPK8/TC	T10, T15, T20, T25, T27, T30, T40 - Torx Power Keys





Combination Pliers

Ref.	Length mm	Max wire dia.mm
PG100	165	1.6
PG101	180	1.8
PG102	200	2.0



Diagonal Cutters

Ref.	Length mm	Max wire dia.mm
PG500	166	1.6
PG501	187	1.8



Long Snipe Nose Plier

Ref.	Length mm	Max wire dia.mm
PG200L	200	1.6



End Cutter

Ref.	Length mm	Max wire dia.mm
PG601	200	2



Bent Snipe Nose Plier

Ref.	Length mm	Max wire dia.mm
PG200LB	194	1.6



Multigrip Plier

Ref.	Length mm	Max Capacity
PG800	240	47

Circlip Pliers

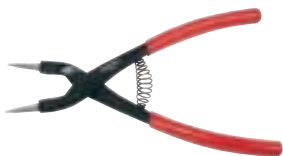

Straight Nose Internal

Ref.	Length mm	Tip dia. mm	Size of Circlips mm	
			Min	Max
PC10	140	0.9	8	12
PC11	140	1.3	12	25
PC12	180	1.8	19	60
PC13	215	2.3	40	100

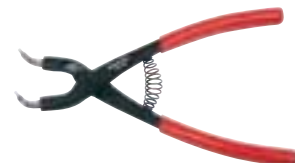

Bent Nose Internal

Ref.	Length mm	Tip dia. mm	Size of Circlips mm	
			Min	Max
PC10B	130	0.9	8	12
PC11B	130	1.3	12	25
PC12B	170	1.8	19	60
PC13B	205	2.3	40	100



Straight Nose External

Ref.	Length mm	Tip dia.mm	Size of Circlips mm	
			Min	Max
PC20	145	0.9	3	10
PC21	145	1.3	10	25
PC22	180	1.8	19	60
PC23	215	2.3	40	100



Bent Nose External

Ref.	Length mm	Tip dia.mm	Size of Circlips mm	
			Min	Max
PC20B	130	0.9	3	10
PC21B	130	1.3	10	25
PC22B	170	1.8	19	60
PC23B	200	2.3	40	100

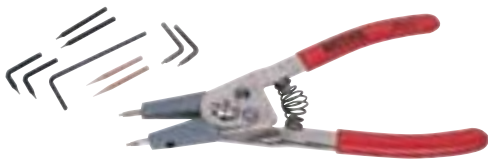

155mm Internal / External

Ref.	Type	Size of Circlips mm		Length
		Min	Max	
CPU21	Internal	8	26	155

Replacement Tips - 155mm

Ref.	Type	Tip Sizes mm
		CPUTIP21
	Bent 90°	0.9, 1.2



240mm Internal / External

Ref.	Type	Size of Circlips mm		Length
		Min	Max	
CPU65	Internal	31	100	240

Replacement Tips - 240mm

Ref.	Type	Tip Sizes mm
		CPUTIP65
	Bent 90°	2.3, 2.7, 3.0

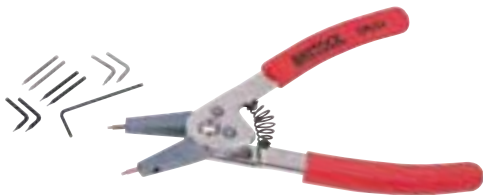

195mm Internal / External

Ref.	Type	Size of Circlips mm		Length
		Min	Max	
CPU34	Internal	10	48	195

Replacement Tips - 195mm

Ref.	Type	Tip Sizes mm
		CPUTIP34
	Bent 90°	0.9, 1.2

Miscellaneous Pliers



PM907



PM902



PM901

Lock Grip Plier

Ref.	Jaw Shape	Length mm	Jaw capacity
PM900	Curved	190	42
PM901	Curved	235	63
PM902	Straight	190	42
PM903	Straight	235	63
PM906	Long Nose	150	37
PM907	Long Nose	250	63



Wire Twisting Pliers

Ref.	Length mm	Max wire mm
PMWT6	170	0.5
PMWT10	241	0.5

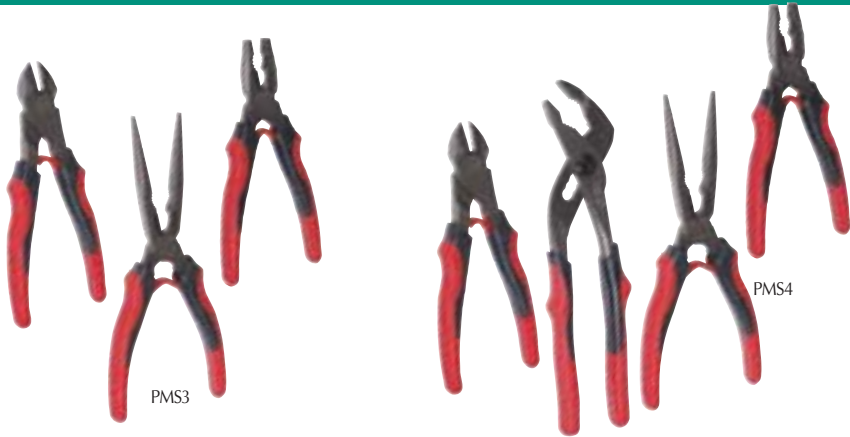

Engineers Plier Sets

Part No	Description	Sizes
PMS3	3 Piece Set	200mm Combination, 200mm Long Nose, 166mm Diagonal Cutter
PMS4	4 Piece Set	200mm Combination, 200mm Long Nose, 166mm Diagonal Cutter, 240mm Multigrip Plier



Interchangeable Circlip Plier Set

Part No	Description	Sizes
CPUSET3	3 Piece Internal/External Interchangeable Plier Set	Internal: 8 - 100mm. External 3 - 100mm



Engineers Plier Set - Hi-tech Foam

Part No	Description	Sizes
PMS4/TC2	4 Piece Set	200mm Combination, 200mm Long Nose, 166mm Diagonal Cutter, 240mm Multigrip



Lock Grip Plier Set - Hi-tech Foam

Part No	Description	Sizes
PMSET3/TC	3 Piece Lock Grip Plier Set	Straight Jaw: 42mm, 63mm. Curved Jaw: 63mm



Circlip Plier Sets

Part No	Description	Sizes
PCS2	4 Piece 19 - 60 mm Circlip Plier Set	Bent Nose Internal/External. Straight Nose Internal/External
PCS3	4 Piece 40 - 100 mm Circlip Plier Set	Bent Nose Internal/External. Straight Nose Internal/External



PLIER3

3 Piece Plier Set

Ref.	Description	Contents
PLIER2	3 Piece Plier Set	180 Combination Plier, 200mm Long Nose Plier, 166mm Side Cutter
PLIER3	3 Piece Plier Set	180 Combination Plier, 200mm Long Nose Plier, 240mm Multigrip Plier

Striking & Cutting



Hammers, Chisels & Punches



- Forged medium carbon steel construction
- Hickory handle – seasoned and kiln processed to ensure the correct moisture content
- Controlled heat treatment – ensuring the correct balance of hardening and tempering

Ball Pein Hammers - Hickory Handle

Ref.	Size (oz)	Length mm
BPH4	4	275
BPH8	8	300
BPH16	16	350
BPH24	24	375
BPH32	32	400



- Ideal for heavy duty hammering where maximum but safe blows are required

Copper / Copper Hammers - Ash Handle

Ref.	Weight (oz)	Hammer No.	Length mm
CCH16	16	A	230
CCH32	32	1	280
CCH48	48	2	305
CCH64	64	3	305



- Hickory handle – seasoned and kiln processed to ensure the correct moisture content

Nylon Soft Faced Hammers

Ref.	Weight (oz)	Hammer No.	Length mm
SFP16	16	32	280
SFP24	24	38	305
SFP32	32	44	305
SFP44	44	50	330



- User adjustable impact strength
- Tips machined from S2 steel
- Brass knurled body for a comfortable secure grip

2 Piece Automatic Centre Punch Set

Ref	Length mm
ACPSET1	125
	150

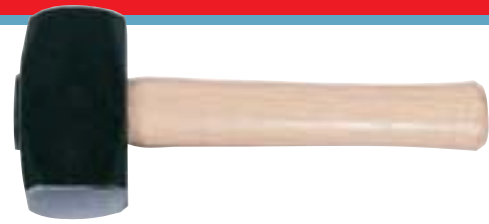

Club Hammer

Ref.	Size lbs	Length mm
MCH4	4	245



- An excellent dual purpose hammer for assembly and repair work

Copper / Rawhide Hammers - Ash Handle

Ref.	Weight (oz)	Hammer No.	Length mm
CRH14	14	A	230
CRH24	24	1	280
CRH40	40	2	305
CRH56	56	3	305



- One piece design
- Shot filled steel head prevents rebound

Dead Blow Hammers

Ref.	Size (oz)	Length mm
DBH18	18	290
DBH42	42	380



- Contains 4 precision ground cold chisels

4 Piece Cold Chisel Set

Ref	Length mm	Width mm
CFCSET1	250	25
	200	20
	190	15
	180	10



- The Britool HS212 hacksaw has a unique design which features a reversed bow. This allows extremely high blade tension levels up to 80kg to be applied progressively
- Blade tension levels of this magnitude are essential to gain the maximum benefit from bi-metal blades

Reversed Bow Hacksaw					
Ref.	Length mm	Height mm	Thickness mm	Blade Length mm	
HS212	385	145	26	300	



Front hand rest

Tensioning system

Two blade positions—45° and 90°

Minimum clearance needed to start cutting



Britool Professional Vices

- All forged, heavy duty steel construction for maximum longevity
- Precision machined for smooth fault free operation
- Integral anvil design
- Interchangeable jaws (excludes EV3)

Britool Professional Vices				
Ref.	Jaw Width(mm)	Jaw Opening(mm)	Jaw Depth(mm)	
EV3	75	90	60	
EV4	100	100	60	
EV5	125	130	75	
EV6	150	190	90	
EV8	205	210	100	

Pry Bars



- Powerful square section blade significantly reduces the spring effect often encountered with this style of pry bar
- Screwdriver style handles give a comfortable grip and significantly enhance the leverage which can be applied

Screwdriver Pry Bars

Ref.	Blade Length mm
SPB175	175
SPB300	300
SPB450	450
SPB600	600



- These pry bars are forged from high quality chrome alloy steel and have a red powder coated finish
- Roll head acts as a fulcrum and increases the level of leverage which can be applied
- Used extensively in the automotive industry for leverage and location, particularly on brake assemblies

Roll Head Pry Bars

Ref.	Length mm	Shank Diameter mm
217-	150	8
218	300	11
219-	413	14.3



3 Piece Screwdriver Pry Bar Set

Ref	Contents
SPBSET	SPB175
	SPB300
	SPB450

www.britool.com

VISIT THE BRITOOOL WEBSITE TO SEE THE LATEST PROMOTIONS, COMPETITIONS AND NEWS



A

Accessories 1/4" sq. drive	17
Accessories 1/2" sq. drive	23, 24
Accessories 3/8" sq. drive	20
Accessories 3/4" sq. drive	28
Adjustable wrenches	44

B

Bit holders	50
Bits - insert	50, 51
Boots	60

C

C-hook wrenches	44
Cantilever tool boxes	12
Centre punches	57
Chisels	57
Circlip pliers	53, 54
Combination wrenches	37, 38, 39, 40, 41

E

Extension bars 1/4" sq. drive	17
Extension bars 3/8" sq. drive	20
Extension bars 1/2" sq. drive	24
Extension bars mixed sq. drive	27

H

Hacksaws	58
Hammers - ball pein	57
Hammers - claw	57
Hammers - club	57
Hammers - copper/ copper	57
Hammers - dead blow	57
Hammers - nylon faced	57
Hand portable tool boxes	12
Hexagon keys	51

I

Impact sockets 3/8" sq. drive	29
Impact sockets 1/2" sq. drive	29
Insert bits	50, 51
Insulated screwdrivers	47

K

Keys - hexagon	51
----------------	----

L

Lock grip pliers	54
------------------	----

M

Mid sections	8
--------------	---

O

Open jaw wrenches	41, 42
-------------------	--------

P

Plier sets	55
Pliers	53, 54, 55
Pliers - bent nose	53
Pliers - combination	53
Pliers - long nose	53
Pliers - multigrip	53
Pliers - wire twisting	54
Podger wrenches	44
Power keys	51
Pry bars	59

R

Ratcheting combination wrenches	37, 38
Ratcheting ring wrenches	37, 38, 43
Ratcheting screwdrivers	49
Ratchets 1/4" sq. drive	17
Ratchets 3/8" sq. drive	20
Ratchets 1/2" sq. drive	23
Ratchets 3/4" sq. drive	28
Ring wrenches	42, 43
Ring wrenches - ratcheting	37, 38, 43
Roller cabinets	4, 5

S

Screwdrivers	46, 47, 48, 49
Screwdrivers - flared tip	46
Screwdrivers - insulated	47
Screwdrivers - pozidriv	47
Screwdrivers - phillips	47
Screwdrivers - ratcheting	49
Screwdrivers - stubby	47
Screwdrivers - torx	46
Side cabinets	7
Side shelf	8
Socket sets 1/4" sq. drive	17, 18, 19
Socket sets 3/8" sq. drive	21, 22
Socket sets 1/2" sq. drive	24, 25, 26
Socket sets 3/4" sq. drive	28
Socket sets mixed sq. drive	27, 28

T

Tape measures	59
Tool carts	5
Tool chests	6, 7
Toolkits	9, 10, 11, 12
Torque drivers	34
Torque multipliers	34
Torque testers	34
Torque wrenches - classic	33
Torque wrenches - dial	33
Torque wrenches - electronic	33
Torque wrenches - series 2	33

V

Vices	58
-------	----

W

Work benches	13
Work boots	60
Wrenches - adjustable	44
Wrenches - C-hook	44
Wrenches - combination	37, 38, 49, 40, 41
Wrenches - open jaw	41, 42
Wrenches - podger	44
Wrenches - ring	42, 43



PART NO	Page No.	PART NO	Page No.	PART NO	Page No.
1BHM	50	2J3344	41	2UTX45	51
1UPHD1T	50	2J3743	41	2UTX50	51
1UPHD2T	50	2J4350	41	2UTX55	51
1UPHD3T	50	2J4452	41	306C	44
1UPHD4	50	2J5056	41	308C	44
1UPZD0	50	2J5260	41	310C	44
1UPZD1T	50	2J5662	41	312C	44
1UPZD2T	50	2J5668	41	3150	44
1UPZD3T	50	2J6071	41	3151	44
1UPZD4	50	2J6268	41	3152	44
1USB093	50	2J6275	41	315C	44
1USB125	50	2J6875	41	318C	44
1USB156	50	2J7182	41	3USB10M	50
1USB187	50	2J7587	41	3USB12M	50
1USB250	50	2J8187	41	3USB14M	50
1USB25M	50	2J8193	41	3USB375	50
1USB2M	50	2J8292	41	3USB500	50
1USB3M	50	2J92101	41	3USB562	50
1USB4M	50	2J93100	41	5J1013	42
1USB5M	50	2J93112	41	5J1115	42
1USB6M	50	2JM1011	41	5J1722	42
1USS45T	50	2JM1013	41	5J1924	42
1USS4T	50	2JM1213	41	5J2432	42
1USS55T	50	2JM1317	41	5J2836	42
1USS65T	50	2JM1415	41	5J3241	42
1USS8T	50	2JM1617	41	708010	18
1UTX10	51	2JM1719	41	708020	18
1UTX10S	51	2JM1819	41	708030	18
1UTX15	51	2JM1922	41	708040	18
1UTX15S	51	2JM2022	41	708110	21
1UTX20	51	2JM2123	41	708120	21
1UTX20S	51	2JM2224	41	708130	21
1UTX25	51	2JM2426	41	708140	21
1UTX25S	51	2JM2427	41	708220	24
1UTX27	51	2JM2430	41	708230	24
1UTX27S	51	2JM2730	41	708240	25
1UTX30	51	2JM3032	41	708260	24
1UTX30S	51	2JM3236	41	708270	24
1UTX40	51	2JM3641	41	708410	27
1UTX40S	51	2JM67	41	708420	27
1UTX6	51	2JM78	41	708430	27
1UTX7	51	2JM810	41	708510	17
1UTX8	51	2JM89	41	708520	20
1UTX9	51	2JMSET8/TC	42	708530	24
217-	59	2UPZD1	50	708540	27
218	59	2UPZD2	50	708550	27
219-	59	2UPZD3	50	748251	18
2J101110	41	2UPZD4	50	748252	18
2J101120	41	2USB187	50	748254	19
2J106112	41	2USB218	50	748255	19
2J106125	41	2USB250	50	748256	19
2J120130	41	2USB312	50	748261	22
2J125143	41	2USB5M	50	748262	21
2J130148	41	2USB6M	50	748263	21
2J131150	41	2USB8M	50	748264	21
2J148167	41	2USS5	50	748267	22
2J162181	41	2USS6	50	748271	26
2J168187	41	2USS7	50	748272	26
2J186205	41	2UTX25	51	748273	26
2J2531	41	2UTX30	51	748274	26
2J3137	41	2UTX40	51	748275	25

PART NO	Page No.	PART NO	Page No.	PART NO	Page No.
748276	25	BRKIT338	11	E85	23
748277	25	BRKIT447	12	E86	23
748289	28	BRKIT470	13	E91	23
748291	28	BRKIT80	11	EF74	23
748293	27	BRSD2	49	EFS20	23
758200	29	BRSDF1	49	EPHS	23
758300	29	BRSDSET1	49	ESHP	23
758500	29	BRSDSET2	49	EV3	58
768261	22	BSCR1	9	EV4	58
9RBM1011	42	BSCR1BL	9	EV5	58
9RBM1213	42	BSCR8	8	EV6	58
9RBM1415	42	BSCR8BL	8	EV8	58
9RBM1617	42	BSH1	10	EVT1200A	33
9RBM1819	42	BSH1BL	10	EVT2000A	33
9RBM67	42	BTBR10	7	EVT3000A	33
9RBM89	42	BTBR10BL	7	EVT600A	33
A1UBA	20	BTBR8	8	FNSET5	43
A1UBA	50	BTBR8W	6	GVT8400	33
A45	20	BTBR8WBL	7	H70	28
A46	20	BTBRD6	7	H74	28
A50T	34	BTBRD6BL	8	H85	28
A70	20	BTCR13BL	6	HK9/C	51
A77	20	BTCR16	6	HKB9/C	51
A91	20	CCH16	57	HKL9/C	51
ACPSET1	57	CCH32	57	HKM9/C	51
AF45	20	CCH48	57	HKMB9/C	51
AFS20	20	CCH64	57	HKML9/C	51
APES	20	CFCSET1	57	HPK10	51
ASEP	20	CM1000	34	HPK2	51
AVT100A	33	CM40	34	HPK2.5	51
AVT300A	33	CM400	34	HPK3	51
AVT600	33	CPU21	54	HPK4	51
BBS109	50	CPU34	54	HPK5	51
BBS31	50	CPU65	54	HPK6	51
BCH1	10	CPUSET3	55	HPK8	51
BCSD1	49	CPUTIP21	54	HPKB10	51
BCSD2	49	CPUTIP34	54	HPKB4	51
BCSD3	49	CPUTIP65	54	HPKB5	51
BMSR3FD	9	CRH14	57	HPKB6	51
BMSR3FDBL	9	CRH24	57	HPKB8	51
BMSR6	10	CRH40	57	HPKM6/S	51
BMSR6BL	10	CRH56	57	HPKM8/TC	51
BMSR8	10	CTB45	13	HS212	58
BPH16	57	D1UBA	17	HVT5000	33
BPH24	57	D1UBA	50	HVT7200	33
BPH32	57	D46	17	MCH4	57
BPH4	57	D70	17	NB108T	42
BPH40	57	D77	17	NB131R	42
BPH8	57	D91	17	NB141C	42
BRCR11	5	DASET5P	17	NB227D	42
BRCR11BL	5	DBH18	57	NB231E	42
BRCR3	4	DBH42	57	NB250P	42
BRCR5	4	DFS20	17	NB351G	42
BRCR5BL	4	DPAS	17	NC381T	43
BRCR6	4	DSAP	17	ND130A	40
BRCR6BL	5	E200T	34	ND150J	40
BRCR7	5	E340T	34	ND243L	40
BRCR7BL	6	E70	23	ND251D	40
BRKIT228	11	E74	23	ND360E	40
BRKIT239	12	E75	23	PC10	53
BRKIT314	12	E77	23	PC10B	53

PART NO	Page No.	PART NO	Page No.	PART NO	Page No.
PC11	53	RBO3743	43	RJM14	39
PC11B	53	RBO5056	43	RJM15	39
PC12	53	RBO6268	43	RJM16	39
PC12B	53	RBO7587	43	RJM17	39
PC13	53	RBOM1112	43	RJM18	39
PC13B	53	RBOM1314	43	RJM19	39
PC20	53	RBOM1517	43	RJM20	39
PC20B	53	RBOM1921	43	RJM21	39
PC21	53	RBOM78	43	RJM22	39
PC21B	53	RBOM910	43	RJM23	39
PC22	53	RBOMSET	44	RJM24	39
PC22B	53	RBOSESET	44	RJM25	39
PC23	53	RBSET/TC	44	RJM26	39
PC23B	53	RCHWRENCH1	44	RJM27	39
PCS2	55	RJ10/STC	41	RJM28	39
PCS3	55	RJ1000	39	RJM30	39
PG100	53	RJ1010	39	RJM32	39
PG101	53	RJ1062	39	RJM34	39
PG102	53	RJ1100	39	RJM36	39
PG200L	53	RJ1125	39	RJM41	39
PG200LB	53	RJ1200	39	RJM46	39
PG500	53	RJ1250	39	RJM50	39
PG501	53	RJ1300	39	RJM55	39
PG601	53	RJ1312	39	RJM6	39
PG800	53	RJ1375	39	RJM60	39
PLIER2	55	RJ1437	39	RJM65	39
PLIER3	55	RJ1480	39	RJM7	39
PM900	54	RJ1500	39	RJM8	39
PM901	54	RJ1625	39	RJM9	39
PM902	54	RJ1687	39	RJMSET11	40
PM903	54	RJ1750	39	RJMSET14/TC	40
PM906	54	RJ1812	39	RJMSET7L/TC	40
PM907	54	RJ1875	39	RJMSET8	40
PMCS1	55	RJ248	39	RJSET8	40
PMS3	55	RJ250	39	RJSMSSET7	40
PMS4	55	RJ312	39	RJXM10	39
PMS4/TC	55	RJ324	39	RJXM11	39
PMSET3/TC	55	RJ338	39	RJXM12	39
PMWT10	54	RJ344	39	RJXM13	39
PMWT6	54	RJ375	39	RJXM14	39
PW200	44	RJ413	39	RJXM15	39
PW250	44	RJ437	39	RJXM16	39
PW300	44	RJ445	39	RJXM17	39
PW350	44	RJ500	39	RJXM18	39
PW450	44	RJ525	39	RJXM19	39
RBB1112	43	RJ562	39	RJXM7/STC	41
RBB1314	43	RJ600	39	RJXMSET10	41
RBB1517	43	RJ625	39	RJXMSET10/TC	40
RBB1618	43	RJ687	39	RRBMSET7/TC	43
RBB1921	43	RJ710	39	RRFJM10	38
RBB2531	43	RJ750	39	RRFJM11	38
RBB3743	43	RJ812	39	RRFJM12	38
RBB4350	43	RJ820	39	RRFJM13	38
RBB5056	43	RJ875	39	RRFJM14	38
RBB5662	43	RJ920	39	RRFJM15	38
RBB6268	43	RJ937	39	RRFJM16	38
RBB7587	43	RJM10	39	RRFJM17	38
RBB78	43	RJM10/STC	41	RRFJM18	38
RBB910	43	RJM11	39	RRFJM19	38
RBMSET/TC	44	RJM12	39	RRFJM8	38
RBO2531	43	RJM13	39	RRFJM9	38

PART NO	Page No.	PART NO	Page No.	PART NO	Page No.
RRFJMSET12	37	SE30/4	47	TPK15	51
RRJM10	38	SE30/5.5	47	TPK20	51
RRJM11	38	SE30/6.5	47	TPK25	51
RRJM12	38	SE30PH1	47	TPK27	51
RRJM13	38	SE30PH2	47	TPK30	51
RRJM14	38	SE50/2.5	47	TPK40	51
RRJM15	38	SE50/3	47	TPK6/S	51
RRJM16	38	SE50PH00	47	TPK8/TC	51
RRJM17	38	SE75/3.5	47		
RRJM18	38	SE75PH0	47		
RRJM19	38	SE75PH1	47		
RRJM8	38	SES100/3.5	47		
RRJM9	38	SES100PH1	47		
RRJMSET1	37	SES125PH2	47		
RRJMSET12F	38	SES150/4	47		
RRJSET7	37	SES175/5.5	47		
RRJSM10	38	SES50/2.5	47		
RRJSM12	38	SES50PH00	47		
RRJSM13	38	SES75PH0	47		
RRJSM14	38	SFP16	57		
RRJSM15	38	SFP24	57		
RRJSM17	38	SFP32	57		
RRJSM19	38	SFP44	57		
RRJSMSET7	37	SL4/S	48		
RRLMSET3	43	SL6/S	48		
RRM1011	38	SL8/S	48		
RRM1213	38	SM100/5.5	46		
RRM1415	38	SM100PZ1	47		
RRM1719	38	SM100T20	46		
RRM810	38	SM100T25	46		
RRMQSET2	37	SM100T27	46		
RRMSET5	37	SM100TPT20	46		
RRPM1719	44	SM100TPT25	46		
RRPM1921	44	SM100TPT27	46		
RRPM2427	44	SM125/6.5	46		
RRSD3	39	SM125PZ2	47		
RRTSET4	38	SM125T30	46		
S2JM10	42	SM125T40	46		
SDRIV1	48	SM125TPT30	46		
SDRIV2	48	SM125TPT40	46		
SDRIV3	48	SM150/6.5	46		
SDRIV4	48	SM150/8	46		
SDRIV5	48	SM150PZ3	47		
SDRIV6	48	SM200/10	46		
SDS11	48	SM200PZ4	47		
SDS5	48	SM250/12	46		
SDS6	48	SM250/8	46		
SDS7	48	SM30PZ1	47		
SDS7/2TC	48	SM30PZ2	47		
SDS8/TC	48	SM75PZ0	46		
SDS9/TC	48	SM75PZ1	47		
SE100/3.5	47	SM75T10	46		
SE100/4	47	SM75T15	46		
SE100PH1	47	SM75TPT10	46		
SE125PH2	47	SM75TPT15	46		
SE150/4	47	SPB175	59		
SE150/5.5	47	SPB300	59		
SE150PH3	47	SPB450	59		
SE175/6.5	47	SPB600	59		
SE200PH4	47	SPBSET	59		
SE250/5	47	TPK10	51		

TRADING TERMS AND CONDITIONS

Prices

- All goods are supplied at prices ruling on the date of receipt of orders. All prices are subject to VAT at the rate ruling on the date of despatch
- All prices quoted are published list prices, in GBP

Minimum Order Value (excl. Spare Parts)

- All orders over £50 net, will be delivered carriage paid to most UK mainland addresses
- All orders received with a net value below £50, will be subject to a surcharge of £10, to cover picking, packing and despatch costs
- All orders above £150 net will be delivered carriage paid for offshore and Scottish Highland regions
- Spare parts, as defined in our published price lists, are subject to separate terms and conditions, which are detailed in the Spare Parts Section of our price lists
- Special delivery instructions (eg. overnight, next day, or direct to the distributor's customer) will be subject to a separate, supplementary charge. For details of the scale of charges, please refer to the Sales Office
- **N.B.** Special supplementary charges are in addition to normal minimum order charges
- Any order requiring split deliveries will be subject to the carriage paid conditions for each component of the order

Additional Export Conditions

- For mainland Europe a minimum nett order value of £200 will be applied.
- For countries outside mainland Europe a minimum nett order of £300 will be applied
- For orders below the minimum order value, a £20 surcharge will be applied to cover export packaging and documentation
- EEC euro zone countries will be invoiced in euros
- For all other countries, invoicing will be in GBP unless specially agreed prior to acceptance of order

Returns

- It is our policy not to accept unauthorised returns (other than repairs or warranty claims)
- All requests for returns must be authorised by a representative of the company prior to return
- All returns which have been authorised (other than returns under guarantee), will be subject to a re-stocking charge of 15%. Where goods require re-packaging, prior to re-stocking the charge will be 25%. The application of this charge will be at the discretion of the company, based upon full and final inspection of the goods as received

Warranty

- Goods accepted against warranty claims will be replaced by the same or an equivalent product, or repaired at the Company's discretion. Credit will not be given except for claims where an equivalent product is no longer available
- The Company reserves the right to accept, or reject all warranty returns, based upon full and final inspection of the goods as received by the Company, or a representative of the Company



GUARANTEE

All Britool products are manufactured to the highest standards and guaranteed against defective materials and workmanship when used for the purpose for which they were designed. All registered trade marks are acknowledged. Prices do not include VAT.

Guarantee Terms and Conditions

General Terms:-

- 1) All products are guaranteed to perform the task for which they were designed, providing they are used under normal working conditions
- 2) This guarantee is supplementary to the legal statutory guarantee
- 3) The guarantee is without time limit, except in cases of:
 - a) Fair wear and tear
 - b) Wilful damage or misuse
 - c) Negligence (inc. failure to adhere to instructions for use, or other recommendations made by the company)
 - d) Alterations and unauthorised repairs
 - e) Where products have a specified fixed period of guarantee, as indicated in the published price list, or in documentation supplied with the product.
 - f) Consumables, which are subject to the legal statutory guarantee only.
- 4) The guarantee offers a free of charge exchange, or repair, limited to defective parts only
- 5) Products no longer in the range will be replaced by an equivalent product, or refunded if there is no equivalent available, at the Company's discretion
- 6) The guarantee gives no right to damages for loss, or consequential loss, under any circumstances

Specific Terms (application of the guarantee):-

- a) Moving parts (eg. ratchet mechanisms) which are subject to wear and tear, have a fixed period of guarantee. Products containing moving parts will be replaced during the guarantee period only. Thereafter, a chargeable repair or reconditioned unit will be offered
- b) Electronic products, which have a fixed period of guarantee, will be replaced or repaired, at the Company's discretion, during the guarantee period only. Thereafter, a chargeable repair or reconditioned unit will be offered. The guarantee does not include upgrades to software based products
- c) Toolboxes and roller cabinets unless stated otherwise are subject to the legal statutory guarantee, and will have moving parts only repaired or replaced under the terms of the guarantee
- d) Products with valves, seals, "O" rings, etc. are subject to a specified fixed period guarantee, outside of which, standard repair charges will apply
- e) For products issued with a Certificate of Calibration, the maintenance of the accuracy of such calibration, is outside the scope of the guarantee
- f) All repairs and refurbished products have a guarantee of 3 months only, against parts and labour

Conditions of Sale:-

Your attention is drawn to our Conditions of Sale which are printed at the back of this price list



It is important to follow the Health and Safety warnings supplied with each product

The Britool Guarantee

General Terms

1. All products are guaranteed to perform the task for which they were designed, provided they are used under normal working conditions.
2. This guarantee is in addition to your statutory rights.
3. This guarantee is without time limit, except in cases of:
 - a. Fair wear and tear.
 - b. Wilful damage or misuse.
 - c. Negligence (including failure to adhere to instructions for use or other recommendations made by the Company).
 - d. Alterations and unauthorized repairs.
 - e. Where products have a specified fixed period of guarantee, as indicated in the published price list, or in documentation supplied with the product.
 - f. Consumables, which are subject to the legal statutory guarantee only.
4. The guarantee offers a free of charge exchange or repair, limited to defective parts only.
5. Products no longer in the range will be replaced by an equivalent product or refunded if there is no equivalent available, at the Company's discretion.
6. The guarantee gives no right to damages for loss, or consequential loss under any circumstances.

Specific Terms Applicable To The Guarantee

1. Moving parts (eg ratchet mechanisms) which are subject to wear and tear have a fixed period of guarantee. Products containing moving parts will be replaced during the guarantee period only. Thereafter, a chargeable repair or reconditioned unit will be offered.
2. Electronic products, which have a fixed period of guarantee will be replaced or repaired at the company's discretion, during the guarantee period only. Thereafter a chargeable repair or reconditioned unit will be offered. The guarantee does not include upgrades to software based products.
3. Toolboxes, roller cabinets and workbenches, unless otherwise stated are subject to the statutory guarantee. Moving parts will only be replaced or repaired under the terms of the guarantee.
4. Products with valves, seals, O-rings, etc are subject to a specified fixed period guarantee, outside of which standard repair charges will apply.
5. For products issued with a Certificate of Calibration, the maintenance of the accuracy of such calibration is outside the scope of the guarantee.





Product Catalogue 2010

Sales Tel: +44 (0) 1142 917266 Sales Fax: +44 (0) 1142 917131

Sales email: britoolcustomerservice@britool.com

www.britool.com



Europa View, Sheffield Business Park, Sheffield S9 1XH.