

NEW



Board-to Cable Connector
For LED Lighting Power Supply

ES3 Series (WF2 Type)

CONNECTOR

MB-0227-1

September 2011

RoHS Compliant

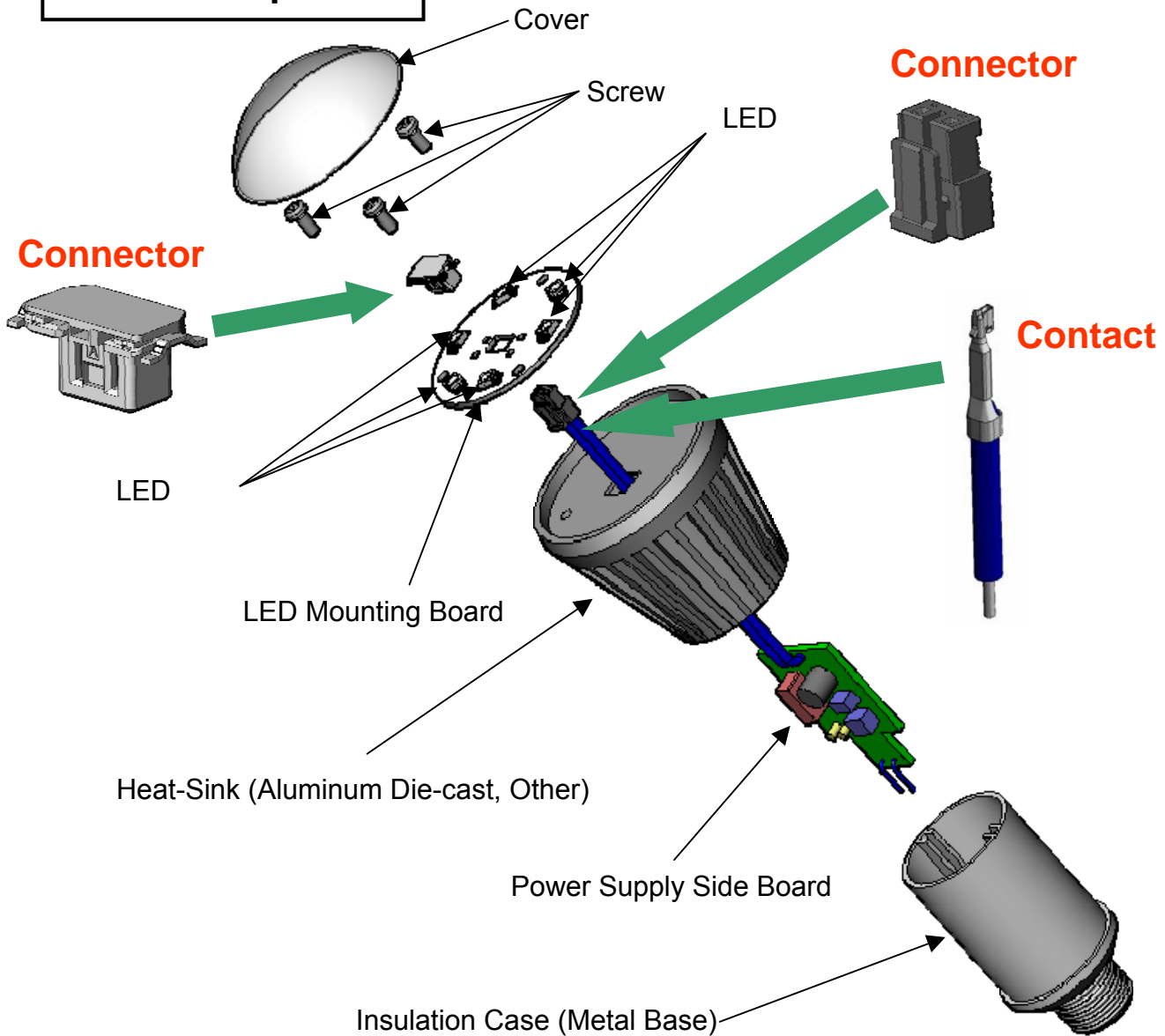

Drawing of LED Light Bulb Assembly (For Reference)

The ES3 Series is a board-to-cable type, 2 position connector ideal for LED lighting devices like LED light bulbs, and downlights.

This connector enables direct connection of the converter board and the LED mounting board with a cable.

The pin connector for the LED mounting board connection is available in embossed reel packaging for SMT automated mounting.

It allows reflow solder mounting to the LED mounting board to occur at the same time that other LED chips and SMT electrical parts are mounted.

Features

- Low-profile design (mounting height: 1.65mm) to prevent interference with emission of LED light.
- Insulator for pin connector uses white LCP with superior heat and light resistance ideal for the mounted environment.
- Board-to-cable connection of LED mounting board and converter board allows for greater freedom in the layout of parts.
- Mechanical lock strongly resists vibration and pulling to prevent un-mating and incomplete mating.
- Uses the IL-Z Series socket contact, which has a long sales history.

General Specifications

- No. of Contacts: 2 pos.
- Contact Resistance: 30mΩmax. (initial)
- Dielectric Withstanding Voltage:
AC2000Vr.m.s per minute
- Mating Cycles: 20 times
- Connector Insertion Force: 15N max.
- Rated Current: 2A
- Rated Voltage: AC, DC 200V
- Insulation Resistance: 10MΩmin. (after test)
- Operating Temperature:
-40 Deg. C to +105 Deg. C
- Applicable Wire: 22AWG to 26AWG

Materials and Finishes

ES3B002WF2

| Component | Material and Finish |
|-----------|---------------------------|
| Insulator | White LCP |
| Contact | Copper alloy / Sn plating |

ES3S002SZA

| Component | Material and Finish |
|-----------|---------------------|
| Socket | 66 Nylon |

IL-Z-C1-A-7000

| Component | Material and Finish |
|----------------|------------------------------|
| Socket Contact | Phosphor bronze / Sn plating |

Ordering Information

ES3 B 002 W F 2 R****

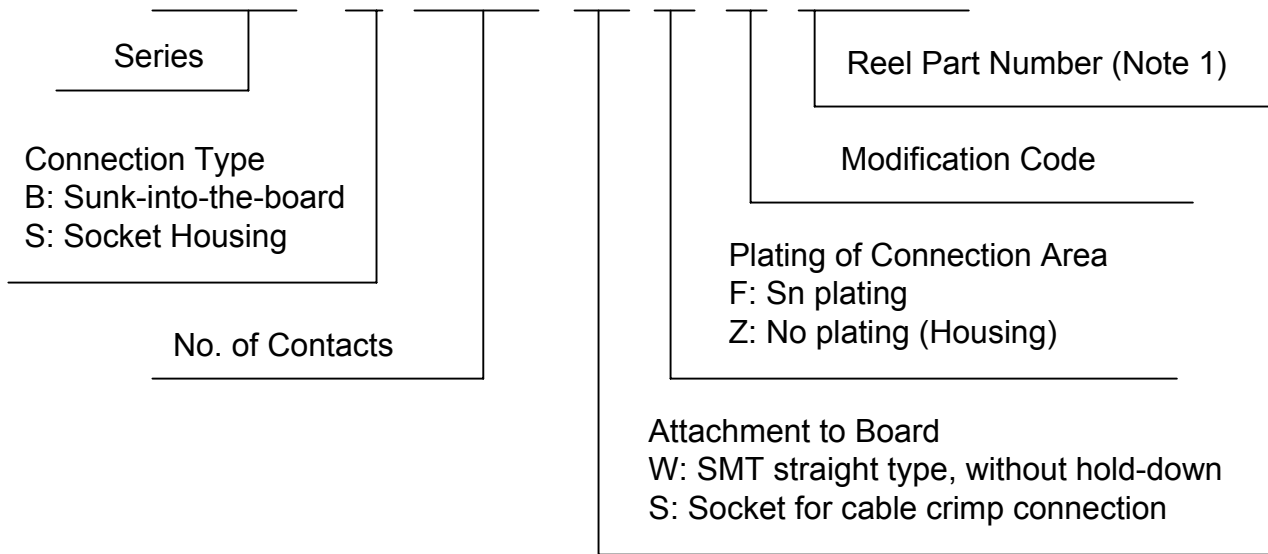

Note1) An embossed tape reel contains 1,000 pieces.

Part Number List

| Type | Part Number | Drawing No. |
|------------------|----------------|-------------|
| Pin Connector | ES3B002WF2 | SJ111730 |
| Socket Connector | ES3S002SZA | SJ111733 |
| Contact | IL-Z-C1-A-7000 | SJ026615 |

Product Drawing

| | |
|-------------|------------|
| Part Number | ES3B002WF2 |
| Drawing No. | SJ111730 |

Unit: mm

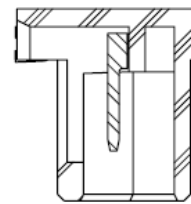
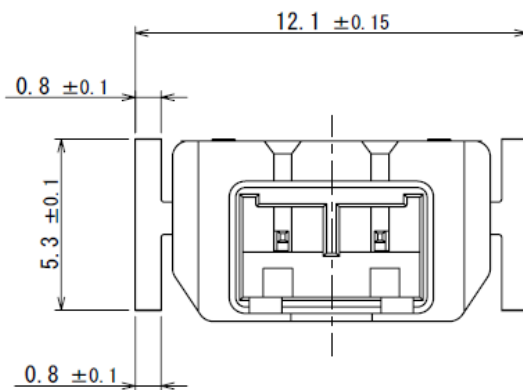
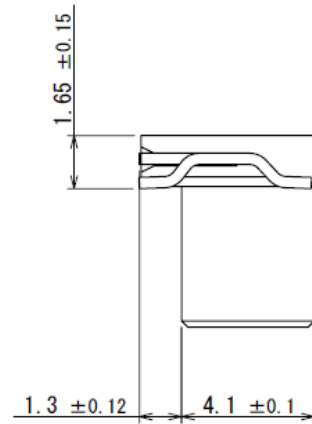
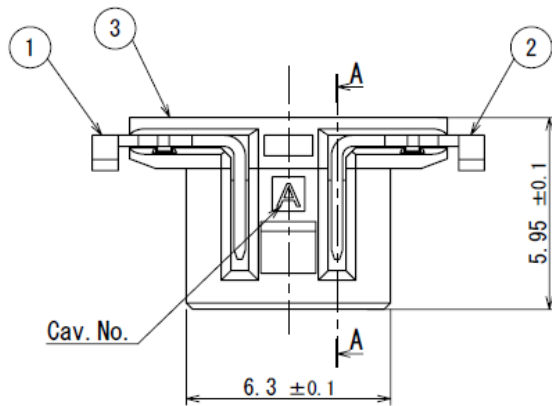
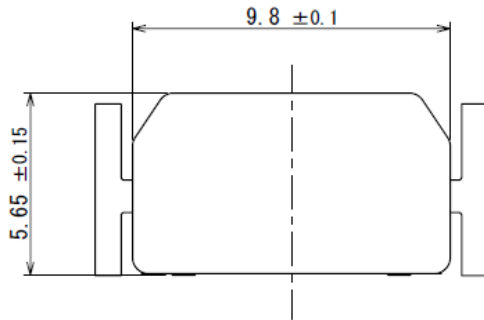

A-A
(5 : 1)

| | | | | | |
|-----------|-------------------|------------|----------------|-----------------------|---------------|
| 3 | INSULATOR | 1 | LCP | | COLOR: WHITE |
| 2 | CONTACT-R | 1 | COPPER ALLOY | LEAD-FREE TIN PLATING | |
| 1 | CONTACT-L | 1 | COPPER ALLOY | LEAD-FREE TIN PLATING | |
| 符号 NO. | 名称 DESCRIPTION | 個数 QTY. | 材料 MATERIAL | 仕上 FINISH | 備考 REMARKS |

Unit: mm

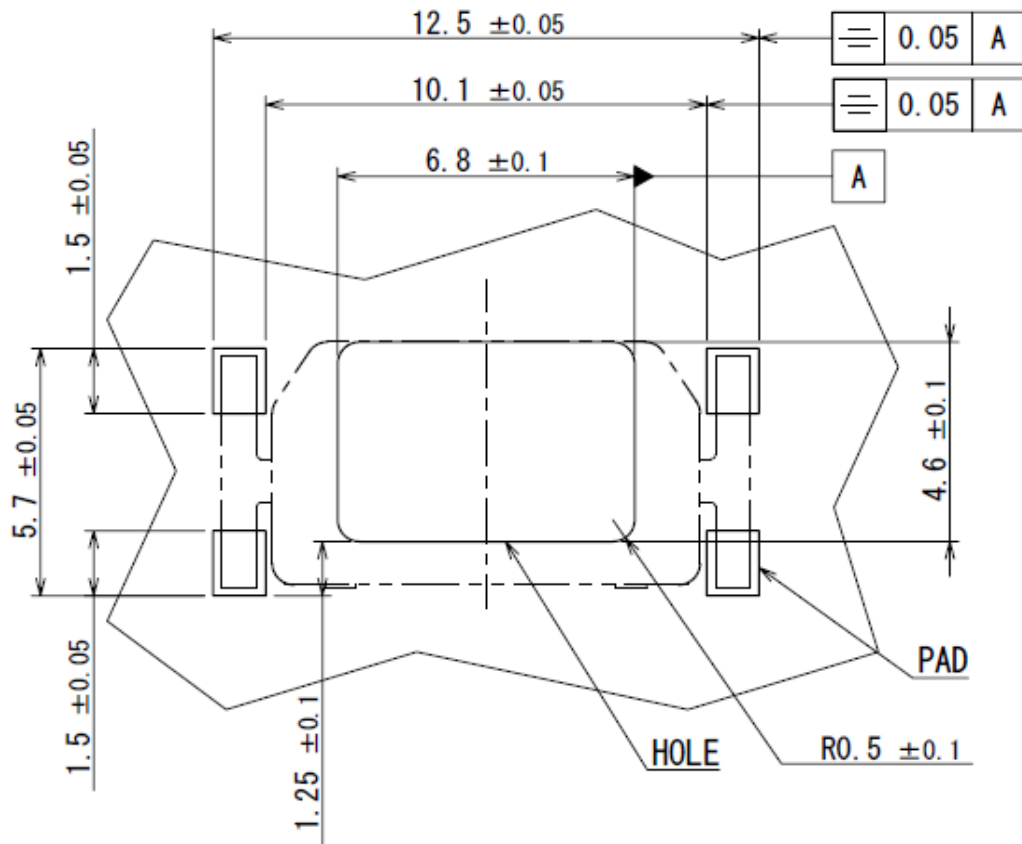

Applicable Board Dimensions (SMT Side) (For reference)

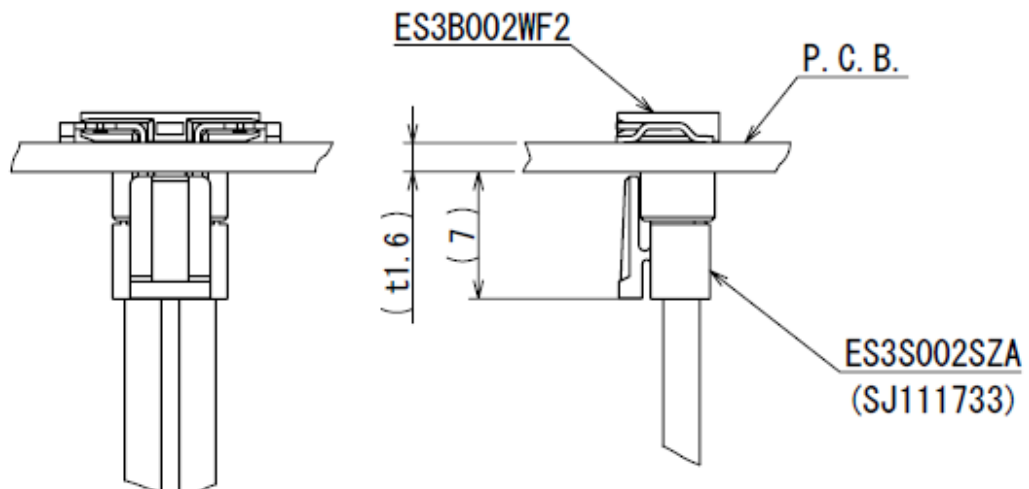

Drawing When Mated (For reference)

| | |
|-------------|-----------------|
| Part Number | ES3B002WF2R1000 |
| Drawing No. | SJ111731 |

Unit: mm

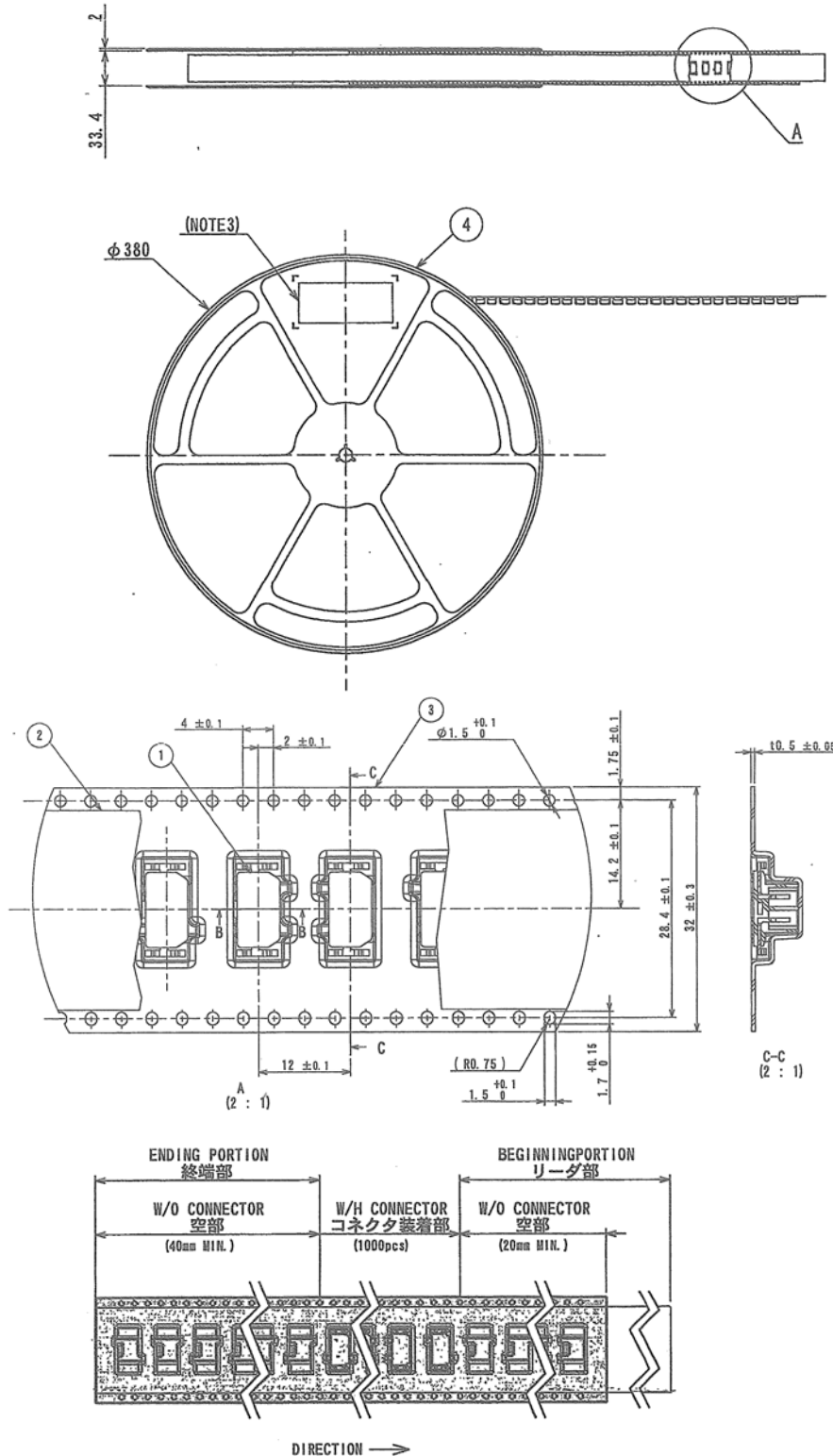

| 符号 NO. | 名称 DESCRIPTION | 個数 QTY. | 材料 MATERIAL | 仕上 FINISH | 備考 REMARKS |
|--------|----------------|---------|-------------|-----------|-----------------------|
| 4 | REEL | 1 | POLYSTYRENE | | |
| 3 | CARRIER TAPE | 1 | POLYSTYRENE | | |
| 2 | COVER TAPE | 1 | POLYESTER | | |
| 1 | CONNECTOR | 1000 | | | ES3B002WF2 (SJ111730) |

| | |
|-------------|------------|
| Part Number | ES3S002SZA |
| Drawing No. | SJ111733 |

Unit: mm

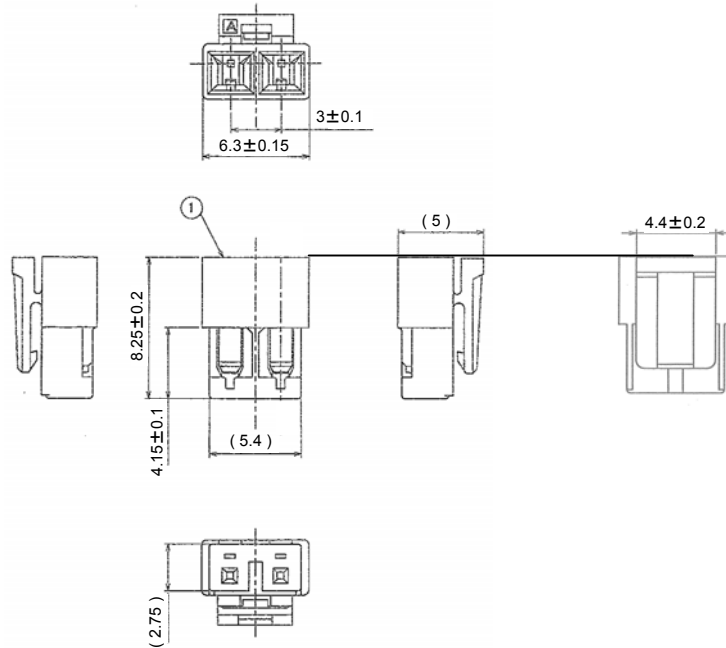

| | | | | | |
|--------|----------------|---------|-------------|-----------|--------------|
| 1 | HOUSING | 1 | 6-6Ny | — | COLOR: BLACK |
| 符号 NO. | 名称 DESCRIPTION | 個数 QTY. | 材料 MATERIAL | 仕上 FINISH | 備考 REMARKS |

| | |
|-------------|----------------|
| Part Number | IL-Z-C1-A-7000 |
| Drawing No. | SJ026615 |

Unit: mm

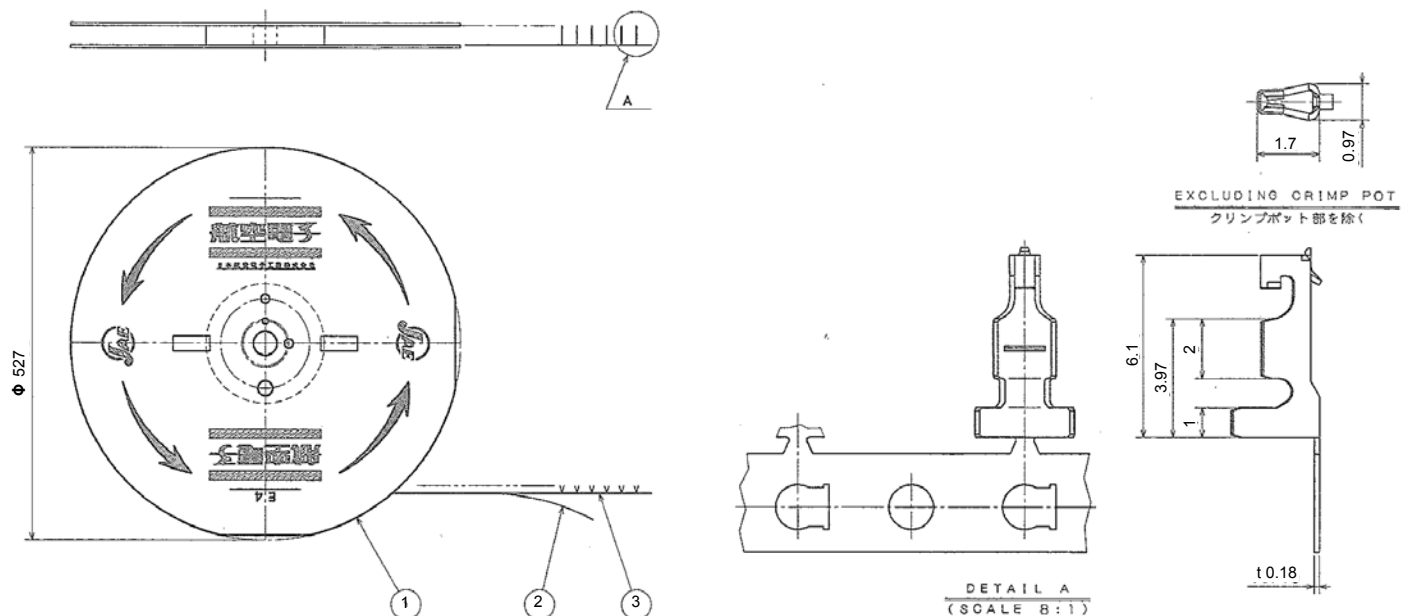

| | | | | | |
|---------|----------------|---------|-----------------|-------------|----------------------|
| 3 | SOCKET CONTACT | 7000 | PHOSPHOR BRONZE | TIN PLATING | TIN PLATING 1µm min. |
| 2 | PAPER TAPE | 1 | PAPER | — | — |
| 1 | MAGAGINE | 1 | PAPER | — | — |
| ITEM 符号 | DESCRIPTION 名称 | Q'TY 個数 | MATERIAL 材料 | FINISH 仕上 | REMARKS 備考 |

Crimping Tool

| Cable Size | Hand Tool | Press | Semi Automatic Applicator |
|----------------|--------------|----------|---------------------------|
| AWG22 to AWG26 | CT150-4-ILZ1 | CP215-5B | 3502-ILZ1-2 |

Technical Bulletin

| | |
|--------------------|------------|
| Specification | JACS-10804 |
| Instruction Manual | JAHL-10804 |

Japan Aviation Electronics Industry, Limited

Product Marketing Division
 Aobadai Building, 3-1-19, Aobadai, Meguro-ku, Tokyo 153-8539
 Phone: +81-3-3780-2787 FAX: +81-3-3780-2946

Notice: Products shown in this brochure are made for the applications listed below. However, if the above-mentioned products are to be used in aerospace devices, marine cable-connection devices, atomic power control systems, medical equipment for life-support systems, or any other specific application requiring extremely high reliability, please contact JAE for further information.
 Recommended applications: Computers, Office machines, Measuring devices, Telecommunication devices (Terminals, Mobile devices), AV devices, Household applications, FA devices, etc.