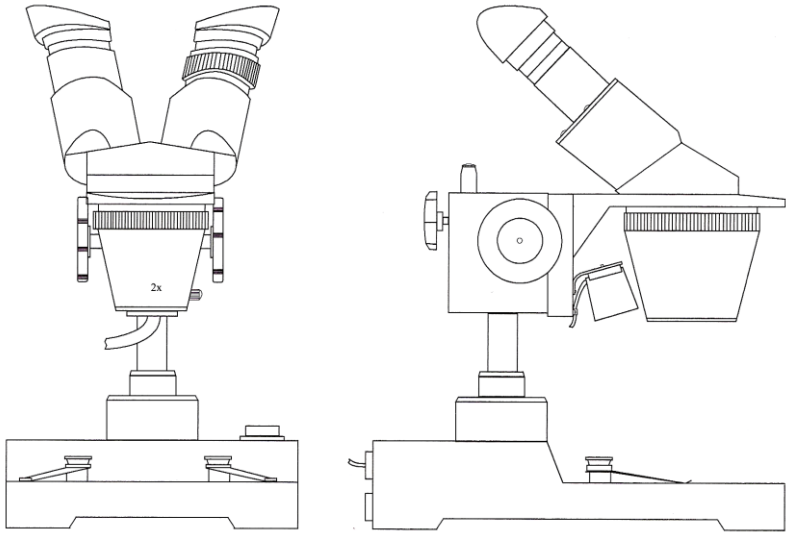
	<p>General Specifications:</p> <ul style="list-style-type: none"> Two 10x Wide Field Eye Pieces Two Rubber Eye Cups Eye Pieces mounted at 45° in Microscope Head Eye Piece width adjustment: 50 – 75mm Vision correction adjustment 2x and 4x Objective Lenses mounted in revolving turret Standard viewing magnification: 20x and 40x mag. Max. working height between stage plate and turret 130mm Rack and pinion focussing and height adjustment 50mm Reversible 60mm diameter stage plate with black / white faces On / Off Illumination Switch Two specimen clips Primary voltage: 230V AC Secondary voltage: 12V 6W
---	---

	<p>Parts List</p> <ul style="list-style-type: none"> 1 Rubber Eye Cups 2 Vision Correction Ring 3 Wide Field Eye Piece 4 Microscope Head 5 Objective Lens Turret 6 Illumination 7 Column Clamp Screw 8 Height Adjustment / Focussing Wheels 9 Fuse Holders 10 Illumination Switch 11 Specimen Clips
--	---

Accessories:

Code	Description	Additional Information
59-020-041	Eye Piece 15X mag.	
59-020-042	Eye Piece 20X mag.	
59-020-045	Eye Piece 10X mag. with Measuring Scale:	Marked: Horizontal Scale: 0-16mm, grads 0.1mm Vertical Scale: 0-16mm, grads 0.5mm Angles: 30, 45 & 60 degrees
59-020-039	Illumination Lamp: Festoon type 12V – 6W Glass Fuse: 250VT1A	2 required

Stereo Microscope: 59-020-040

Page 1 of 2

Magnification Data

Required Viewing Magnification	Wide field Eyepiece Magnification	Objective Lens Magnification	Focal Length mm	Field of View mm
20	10	2	55	10
40	10	4	55	5
30	15	3	55	6
60	15	4	55	3
40	20	2	55	3
80	20	4	55	1.5

Operating Instructions:

- Carefully unpack the microscope from its fitted shipping box
- Remove the protective plastic bag which covers the microscope
- Place the microscope onto a solid working surface
- Remove the two wide field eye pieces from their plastic tubes and fit into the microscope head
- It will be necessary to loosen the small cross head screw situated in the lens mounting tube to allow the lens to be fully seated. This screw should be retightened so that it locates in to the annular groove in the lens body and stop it from being removed
- Fit the rubber eye cups to the eye pieces
- Remove the protective plastic disc from below the objective lens turret
- Connect the plug to the mains supply
- Rotate the objective lens turret to positively engage either the 2x or 4x lens
- Fit the stage plate with the desired colour facing up
- Place the work piece on to the stage plate
- Unclamp microscope head using column clamp screw
- Move the microscope head so that there is approximately 55mm between the bottom of the objective lens turret and the face of the work piece. Clamp in this position
- Switch on the illumination if required
- Look in to the eye pieces and adjust to suit your eye width distance by pulling or pushing the lenses apart
- Rotate the height adjustment wheel to gain focus on the work piece
- Once general focussing has been achieved, final focussing can be carried out to balance any magnification difference between your eyes by adjusting the vision correction ring situated on the left hand lens mount
- The microscope head can be locked in this position by using the "C" spanner provided to tighten the locking collar situated on one of the adjusting knob spindles

Instrument Care:

- Do not dismantle any part of the optical system
- Clean the magnification lenses only, with soft clean dry paper
- Do not try to turn the viewing head through 180° as the optical system is not designed to work in this position