

ASSEMBLY

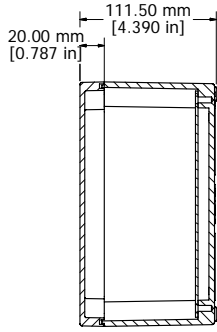

SECTION A-A

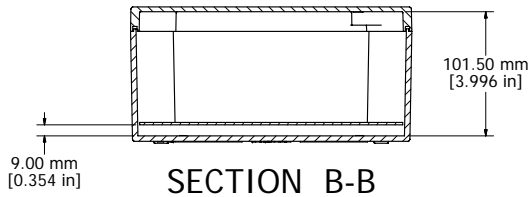

SECTION B-B

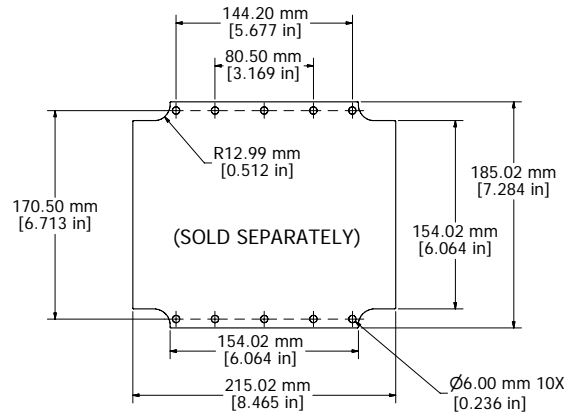

1590Z231PL

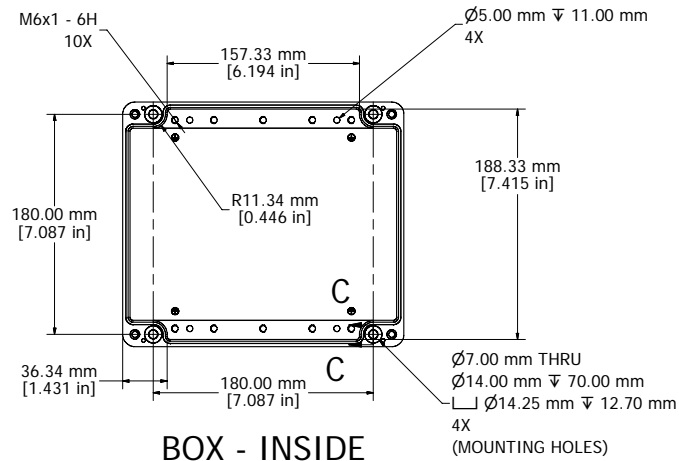

BOX - INSIDE

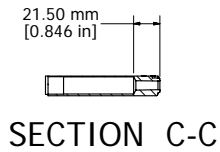

SECTION C-C

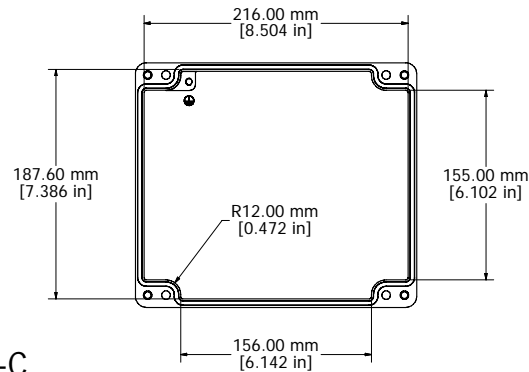

LID - INSIDE

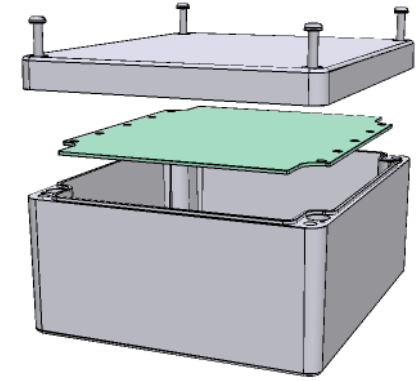

**UL** US LISTED  
File #E65324  
NEMA 4, 4X

Enclosures can be Factory Modified (Milling, Drilling, Printing etc.)  
Contact Factory [mjm@hammondmfg.com](mailto:mjm@hammondmfg.com) for quotes  
Solid models of this enclosure available in STEP or IGES.

NOTES	
Purchased assembly includes enclosure, M6x35 lid screws and M6x10 ground screws.	
Gasket - Preformed Silicone Rubber	
Cover screws should be torqued to 15-17 lbf.in (150-170 cN.m)	

1590Z231	
PART NUMBERS	
Basic Enclosure	1590Z231
Black Enclosure	1590Z231BK
Grey Enclosure - RAL7001 Gloss	1590Z231GY
ACCESSORIES	
Inner Panel	1590Z231PL

**HAMMOND MANUFACTURING™**  
1590Z231  
[www.hammondmfg.com](http://www.hammondmfg.com)