



## STM32100B-EVAL demonstration firmware

---

### Introduction

This user manual describes the demonstration firmware running on the STM32100B-EVAL evaluation board, which can be used to evaluate the capabilities of the value line STM32F100VB microcontroller and on-board peripherals.

The STM32100B-EVAL board is delivered with the demonstration programmed in the internal Flash memory, and all the files needed by the demonstration are programmed in the MicroSD card. At each reset (board power-up, external reset, etc.) the demonstration is executed.

In case the STM32100B-EVAL board was not factory-programmed or the demonstration application was erased, the in-circuit programming (ICP) boot loader can be used to program this file. For more details, refer to [Section 3: STM32100B-EVAL demonstration package](#) and [Section 4: STM32100B-EVAL demonstration programming](#).

*Note:* *Before executing the demonstration, make sure that all evaluation board jumpers are well configured. For more details, refer to STM32100B-EVAL board jumper configuration section.*

This demonstration firmware is available for download from the STMicroelectronics website: [www.st.com](http://www.st.com).

# Contents

- 1 Evaluation board overview . . . . . 7**
  - 1.1 Power control . . . . . 8
  - 1.2 Clocking . . . . . 8
  - 1.3 Reset control . . . . . 8
  - 1.4 Debugging JTAG interface . . . . . 8
  - 1.5 Serial wire debugger interface . . . . . 8
  - 1.6 Embedded ST-LINK . . . . . 8
  - 1.7 Display devices . . . . . 8
    - 1.7.1 LCD . . . . . 8
    - 1.7.2 LED . . . . . 8
  - 1.8 Interfaces . . . . . 9
    - 1.8.1 RS232 . . . . . 9
  - 1.9 Motor control . . . . . 9
  - 1.10 IrDA . . . . . 9
  - 1.11 Miscellaneous peripherals . . . . . 9
    - 1.11.1 Joystick . . . . . 9
    - 1.11.2 Push-buttons . . . . . 9
    - 1.11.3 12-bit analog-to-digital converter (ADC) . . . . . 9
    - 1.11.4 Audio amplifier . . . . . 9
    - 1.11.5 Storage memories . . . . . 9
    - 1.11.6 Temperature sensor . . . . . 10
    - 1.11.7 STM32100B-EVAL board jumper configuration . . . . . 10
  
- 2 Running the demonstration . . . . . 11**
  - 2.1 Menu tree and navigation . . . . . 11
  - 2.2 Demonstration startup . . . . . 12
  - 2.3 Time and date configuration . . . . . 13
  - 2.4 Menu navigation . . . . . 13
    - 2.4.1 Navigation procedure . . . . . 14
  - 2.5 Clock sources . . . . . 15
    - 2.5.1 Clock control . . . . . 15
    - 2.5.2 Clock failure . . . . . 16

---

|          |   |           |
|----------|---|-----------|
| 2.6      | STM32F100VB resources                           | 17        |
| 2.6.1    | Peripherals                                     | 17        |
| 2.6.2    | Interrupts                                      | 18        |
| 2.6.3    | External interrupts                             | 19        |
| 2.6.4    | Internal memory organization                    | 19        |
| 2.6.5    | External memory organisation                    | 19        |
| 2.7      | Demonstration applications                      | 21        |
| 2.7.1    | Product presentation                            | 21        |
| 2.7.2    | Calendar  | 23        |
| 2.7.3    | Images Viewer submenu                           | 27        |
| 2.7.4    | Wave Player submenu                             | 28        |
| 2.7.5    | Low-power modes                                 | 30        |
| 2.7.6    | IDD Measure menu                                | 36        |
| 2.7.7    | Thermometer                                     | 37        |
| 2.7.8    | HDMI CEC submenu                                | 39        |
| 2.7.9    | Help submenu                                    | 41        |
| 2.7.10   | About submenu                                   | 43        |
| <b>3</b> | <b>STM32100B-EVAL demonstration package</b>     | <b>44</b> |
| 3.1      | Libraries                                       | 44        |
| 3.2      | Project   | 45        |
| 3.3      | Utilities                                       | 45        |
| <b>4</b> | <b>STM32100B-EVAL demonstration programming</b> | <b>46</b> |
| 4.1      | Programming the media files                     | 46        |
| 4.2      | Programming the demonstration                   | 46        |
| <b>5</b> | <b>Revision history</b>                         | <b>47</b> |

## List of tables

|          |  |    |
|----------|--|----|
| Table 1. | STM32F100VB demonstration peripherals.....         | 17 |
| Table 2. | STM32F100VB demonstration interrupts.....          | 18 |
| Table 3. | STM32F100VB demonstration external interrupts..... | 19 |
| Table 4. | Document revision history.....                     | 47 |

## List of figures

|            |  |    |
|------------|--|----|
| Figure 1.  | Evaluation board overview . . . . .                      | 7  |
| Figure 2.  | Structure of the demonstration menus . . . . .           | 11 |
| Figure 3.  | SD card check . . . . .                                  | 12 |
| Figure 4.  | Warning message . . . . .                                | 12 |
| Figure 5.  | ST logo . . . . .  | 12 |
| Figure 6.  | STM32 family . . . . .                                   | 13 |
| Figure 7.  | Time and date configuration . . . . .                    | 13 |
| Figure 8.  | Application main menu . . . . .                          | 14 |
| Figure 9.  | Application submenus . . . . .                           | 14 |
| Figure 10. | Navigating in the demonstration menus . . . . .          | 15 |
| Figure 11. | Clock tree diagram . . . . .                             | 16 |
| Figure 12. | No HSE clock detected . . . . .                          | 16 |
| Figure 13. | Standby mode entered . . . . .                           | 17 |
| Figure 14. | Internal Flash memory organization . . . . .             | 19 |
| Figure 15. | MicroSD card organization . . . . .                      | 20 |
| Figure 16. | SDCard removal . . . . .                                 | 20 |
| Figure 17. | Product presentation is ready to start . . . . .         | 21 |
| Figure 18. | First presentation slide . . . . .                       | 21 |
| Figure 19. | Last presentation slide . . . . .                        | 22 |
| Figure 20. | No loaded wave file . . . . .                            | 22 |
| Figure 21. | End of slide show . . . . .                              | 23 |
| Figure 22. | Setting the time and date . . . . .                      | 23 |
| Figure 23. | Time Adjust submenu . . . . .                            | 24 |
| Figure 24. | Time Show submenu . . . . .                              | 24 |
| Figure 25. | Setting the year . . . . .                               | 25 |
| Figure 26. | Setting the month . . . . .                              | 25 |
| Figure 27. | Setting the day of the month . . . . .                   | 26 |
| Figure 28. | Date Show submenu . . . . .                              | 26 |
| Figure 29. | Setting the alarm activation time . . . . .              | 27 |
| Figure 30. | Alarm Show submenu . . . . .                             | 27 |
| Figure 31. | Time and date not configured . . . . .                   | 27 |
| Figure 32. | Images Viewer submenu . . . . .                          | 28 |
| Figure 33. | STM32 Images Viewer . . . . .                            | 28 |
| Figure 34. | Wave Player submenu . . . . .                            | 29 |
| Figure 35. | Wave Player interface . . . . .                          | 29 |
| Figure 36. | Wave Player Playing submenu . . . . .                    | 30 |
| Figure 37. | Pause submenu . . . . .                                  | 30 |
| Figure 38. | Stop mode menu . . . . .                                 | 31 |
| Figure 39. | Stop mode entered . . . . .                              | 31 |
| Figure 40. | MCU in Stop mode . . . . .                               | 31 |
| Figure 41. | RTC Alarm causes the MCU to exit the Stop mode . . . . . | 32 |
| Figure 42. | Setting the wakeup time . . . . .                        | 32 |
| Figure 43. | RTC Alarm wakeup configured . . . . .                    | 32 |
| Figure 44. | RTC Alarm wakeup . . . . .                               | 33 |
| Figure 45. | Time and Date configuration prompt . . . . .             | 33 |
| Figure 46. | Entering Standby mode . . . . .                          | 33 |
| Figure 47. | MCU in Standby mode . . . . .                            | 34 |
| Figure 48. | RTC Alarm causes the MCU to exit Standby mode . . . . .  | 34 |

---

|            |   |    |
|------------|---|----|
| Figure 49. | Setting the wakeup time . . . . .                             | 35 |
| Figure 50. | RTC Alarm wakeup configured . . . . .                         | 35 |
| Figure 51. | Time and Date configuration prompt . . . . .                  | 35 |
| Figure 52. | I <sub>DD</sub> Measure menu . . . . .                        | 36 |
| Figure 53. | I <sub>DD</sub> Run mode menu . . . . .                       | 36 |
| Figure 54. | I <sub>DD</sub> Stop mode menu . . . . .                      | 36 |
| Figure 55. | I <sub>DD</sub> Sleep mode menu . . . . .                     | 37 |
| Figure 56. | Thermometer submenu selected . . . . .                        | 38 |
| Figure 57. | Temperature display . . . . .                                 | 38 |
| Figure 58. | Warning temperature display . . . . .                         | 38 |
| Figure 59. | Temperature sensor error . . . . .                            | 39 |
| Figure 60. | HDMI CEC submenu selected . . . . .                           | 39 |
| Figure 61. | HDMI CEC configuration submenu . . . . .                      | 40 |
| Figure 62. | CEC menu . . . . .  | 40 |
| Figure 63. | Select CEC command . . . . .                                  | 40 |
| Figure 64. | Receive subscreen information . . . . .                       | 41 |
| Figure 65. | Help submenu . . . . .  | 41 |
| Figure 66. | Joystick buttons . . . . .                                    | 42 |
| Figure 67. | Second help slide . . . . .                                   | 42 |
| Figure 68. | About submenu . . . . .                                       | 43 |
| Figure 69. | STM32100B-EVAL demonstration package directory tree . . . . . | 44 |
| Figure 70. | SD card directory organization . . . . .                      | 46 |

# 1 Evaluation board overview

The STM32100B-EVAL microcontroller evaluation board provides a development and demonstration platform for STM32F100xx-based applications. It allows to evaluate the major functions of the STM32F100VB microcontroller.

*Figure 1* summarizes the main functional blocks of the evaluation board.

**Figure 1. Evaluation board overview**

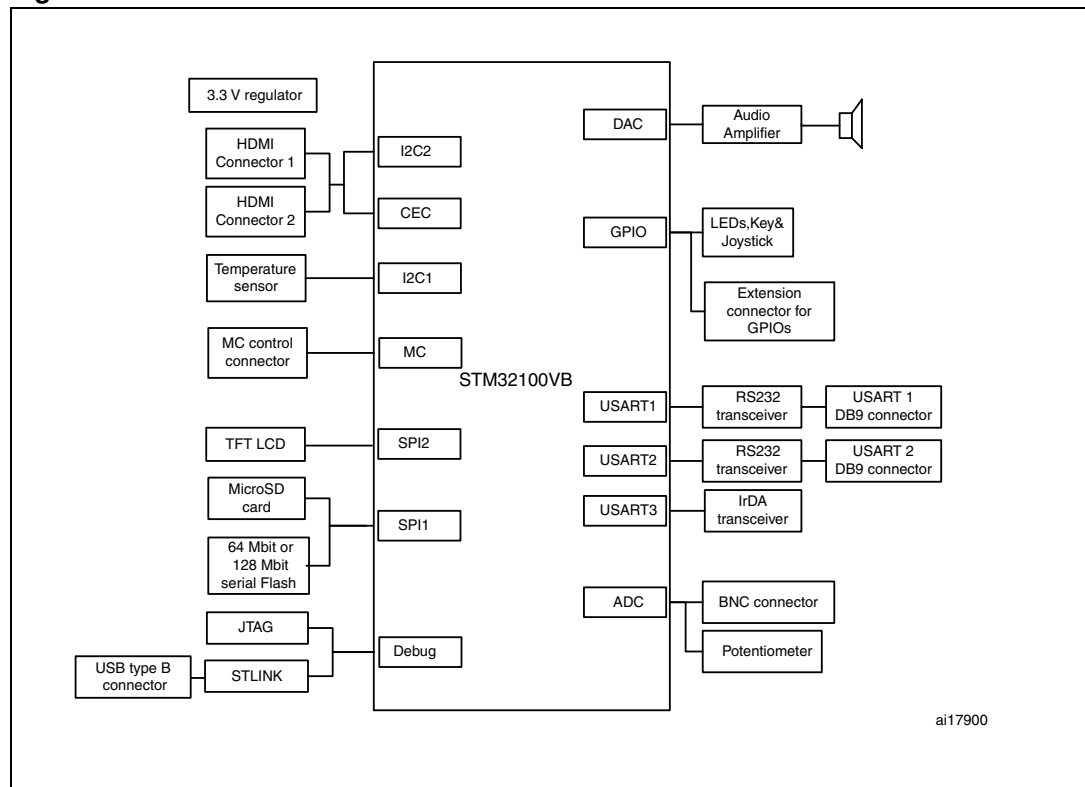

## 1.1 Power control

The evaluation board can be powered from an external 5 V supply or from the USB connector. All other required voltages are provided by on-board voltage regulators.

## 1.2 Clocking

Two clock sources are available on the STM32100B-EVAL evaluation board:

- 32 kHz crystal for embedded RTC
- 8 MHz crystal for STM32F100VB main clock system

## 1.3 Reset control

The reset can be generated by hardware or software:

- Reset button: activates the RESET input when pressed
- JTAG reset

## 1.4 Debugging JTAG interface

Software debug is done via the standard ARM<sup>®</sup> JTAG interface, a 20-pin IDC (insulation displacement connector) for connection to the standard ARM host interface.

## 1.5 Serial wire debugger interface

The serial wire debug port (SWD-DP) provides a 2-pin (clock + data) interface to the AHP-AP port.

## 1.6 Embedded ST-LINK

The ST-LINK in-circuit debugger/programmer is embedded on the board. It supports the STM32F100VB MCU.

## 1.7 Display devices

### 1.7.1 LCD

A color LCD module is mounted on the STM32100B-EVAL board. It is interfaced through the embedded SPI peripheral.

### 1.7.2 LED

Four general-purpose LEDs are available.



## 1.8 Interfaces

### 1.8.1 RS232

The STM32F100VB evaluation board (STM32100B-EVAL) provides two on-board RS-232 serial ports. Both RS232 ports are accessed via DB9 connectors.

## 1.9 Motor control

The STM32100B-EVAL evaluation board supports inductor motor control via a 34-pin connector. This connector provides all required control and feedback signals to and from the motor power-driving board.

### 1.10 IrDA

The STM32100B-EVAL evaluation board supports IrDA communication. The interface is mounted on USART3.

## 1.11 Miscellaneous peripherals

### 1.11.1 Joystick

The board features a four-direction joystick with a selection key.

### 1.11.2 Push-buttons

The following push-buttons are available:

- Key
- Tamper
- Wakeup: used to wake up the processor from low power mode

### 1.11.3 12-bit analog-to-digital converter (ADC)

The MCU ADC channel (ADC1\_IN14) is connected to an on-board variable resistor. The variable resistor provides a voltage in the range of 0 V to 3.3 V.

Moreover, a BNC connector is available for analog input.

### 1.11.4 Audio amplifier

The STM32100B-EVAL evaluation board implements a dedicated audio amplifier which can be interfaced with the STM32 DAC peripheral. For the audio output, a speaker and an audio jack connector are available on the board and connected to the DAC.

### 1.11.5 Storage memories

The STM32100B-EVAL evaluation board features an 8 Mbyte SPI Flash memory and an SD Card™ memory connected to the SPI1 peripheral.

### 1.11.6 Temperature sensor

The STM32100B-EVAL evaluation board includes an I<sup>2</sup>C temperature sensor connected to the I2C1 peripheral.

### 1.11.7 STM32100B-EVAL board jumper configuration

To run the STM32100B-EVAL demonstration correctly, you must configure the following STM32100B-EVAL board jumpers as follows:

- Audio DAC JP2: fitted
- JP8: position MCU<->IDD

## 2 Running the demonstration

### 2.1 Menu tree and navigation

Figure 2 shows the menu system of the STM32F100VB demonstration. The main menu is shown on the left-hand side. The UP, DOWN, RIGHT and LEFT joystick directions allow the user to navigate between items in the main menu and the submenus. To enter a submenu, press the SEL push-button (the SEL push-button is the switch closure that occurs when the joystick button is pushed). To exit a submenu, select the **Return** menu and press SEL.

Figure 2. Structure of the demonstration menus

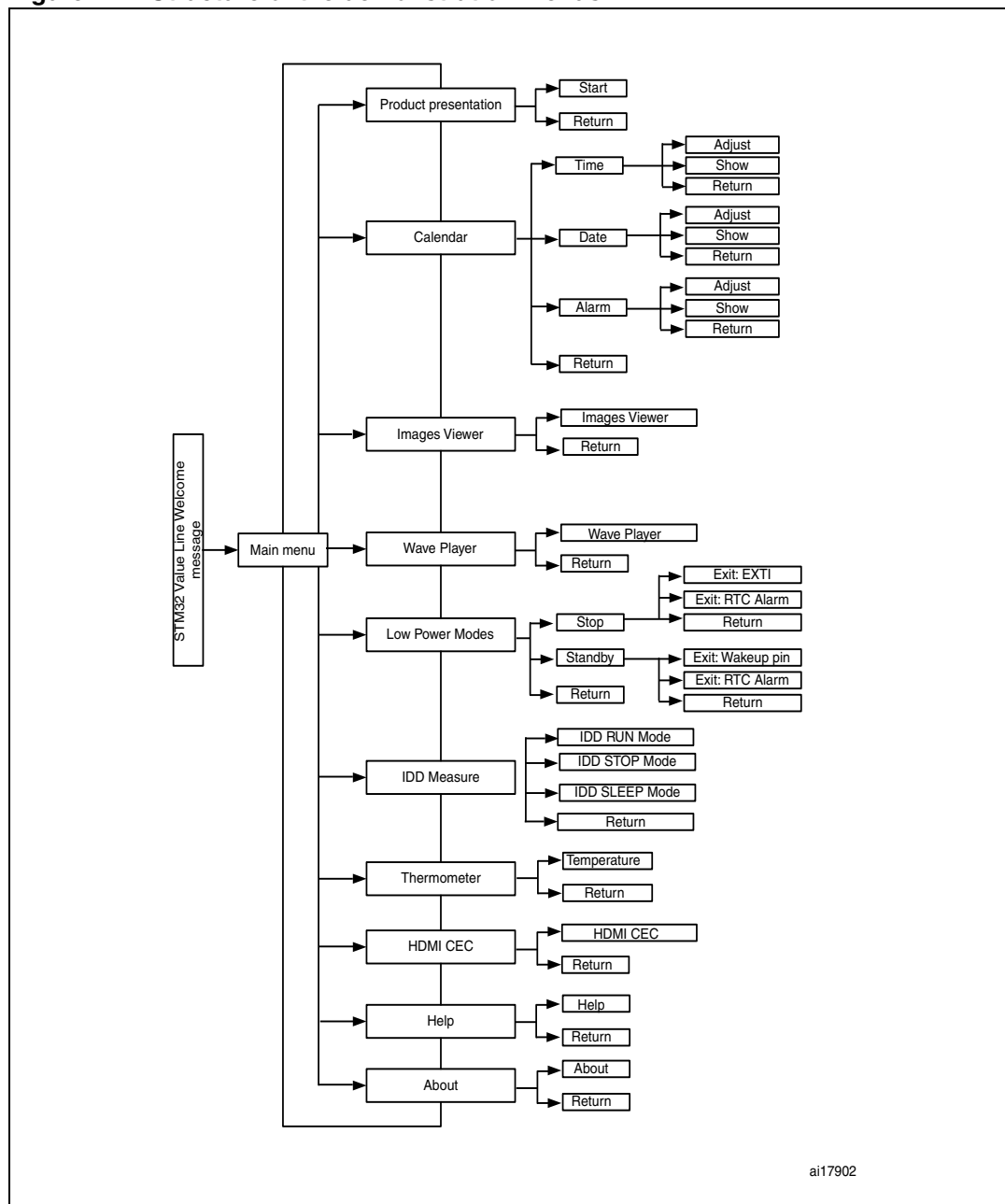

## 2.2 Demonstration startup

The demonstration starts after a board reset. The system checks if an SD memory card is already plugged into the connector CN11. If no card detected, the demonstration does not start and the message shown in [Figure 3](#) is displayed on the LCD screen.

**Figure 3. SD card check**

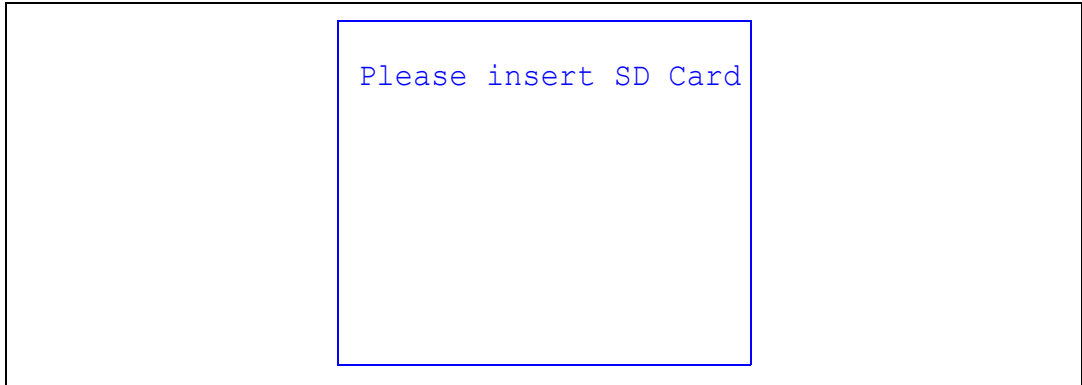

To continue the demonstration, insert an SD card. The demonstration graphic icons and bitmap files are now checked in the MicroSD card (see [Section 2.6.5: External memory organisation](#)). All the icons have to be correctly programmed in the MicroSD card for the demonstration to start. If an icon is missing, the demonstration does not start and the message shown in [Figure 4](#) is displayed on the LCD screen.

**Figure 4. Warning message**

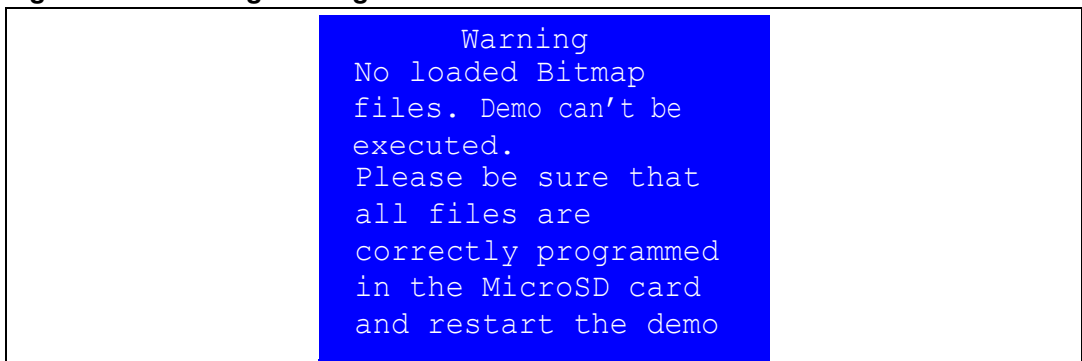

If the icons are correctly loaded into the SD card memory, the welcome screen is displayed and the ST logo appears on the LCD screen:

**Figure 5. ST logo**



After some seconds, the following STM32 slide is displayed on the LCD screen:

**Figure 6. STM32 family**



## 2.3 Time and date configuration

When the board is powered up for the first time and no power supply is detected on  $V_{BAT}$  (battery), you are prompted to set the time, year, month and day. The following message appears on the LCD screen.

**Figure 7. Time and date configuration**

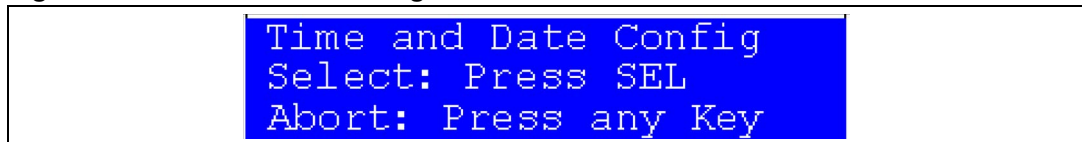

To set the time and date, press the SEL push-button. The **Time Adjust** and **Date Adjust** menus are displayed. Use the joystick UP/DOWN and SEL push-buttons to set the time/date.

To ignore the configuration sequence, press any key except for the SEL push-button. The main menu is displayed.

- Note:*
- 1 You can set the time parameters at any time by using the **Calendar** menu (see [Section 2.7.2: Calendar](#)).
  - 2 If the time has already been configured, then the number of elapsed days (higher than 1 day) from the last time the demonstration board was powered up appears on the LCD screen. It is soon followed by the current date.

## 2.4 Menu navigation

Once the time/date have been set, the main menu appears. The main menu is displayed in the form of a set of icons. It presents all the submenus in the same screen. You can navigate through the submenus by pressing the joystick UP, DOWN, RIGHT and LEFT. To enter the desired submenu, press the SEL joystick push-button, and the submenu corresponding to the selected icon is displayed.

**Figure 8. Application main menu**

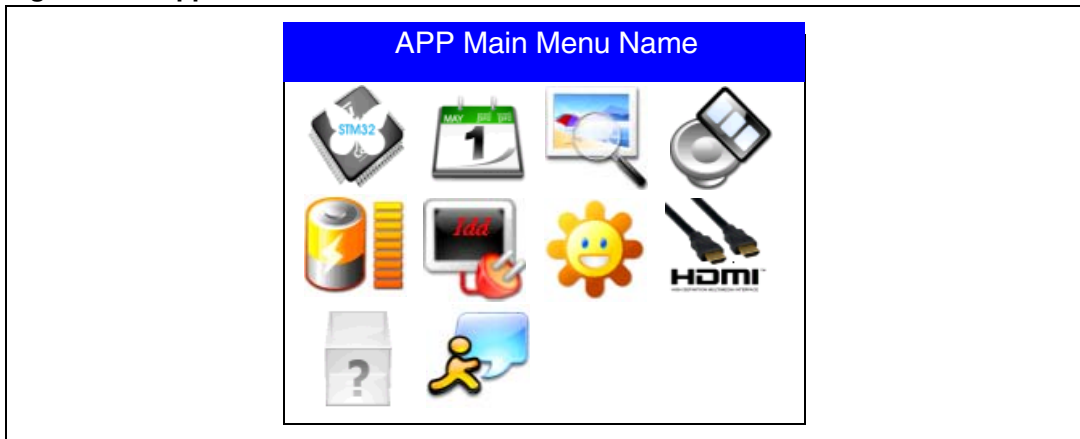

1. The icons shown in *Figure 8* are taken from [http://commons.wikimedia.org/wiki/Crystal\\_Clear](http://commons.wikimedia.org/wiki/Crystal_Clear).

Once a submenu has been selected, the name of the application is listed at the top of the display and all the corresponding submenus are listed below as shown in *Figure 9*.

**Figure 9. Application submenus**

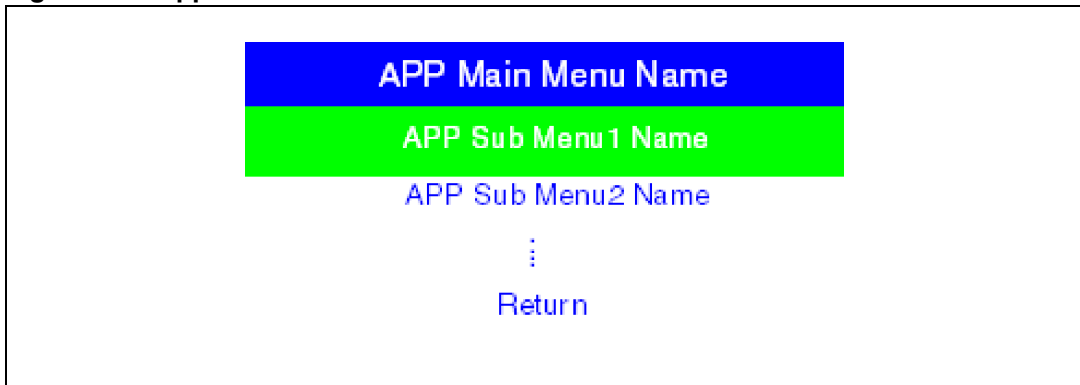

### 2.4.1 Navigation procedure

The demonstration menu is based on circular navigation, submenu selection, item selection and back capability.

To navigate through the demonstration menus, use the joystick push-buttons located on the evaluation board: RIGHT, LEFT, UP, DOWN and SEL.

- The UP, DOWN, RIGHT and LEFT push-buttons are used to perform circular navigation in the main menu and the current menu items
- The SEL push-button selects the current item
- The UP and DOWN push-buttons are used for vertical navigation in the submenus

To return to the upper menu, go to the **Return** menu and press SEL.

**Figure 10. Navigating in the demonstration menus**

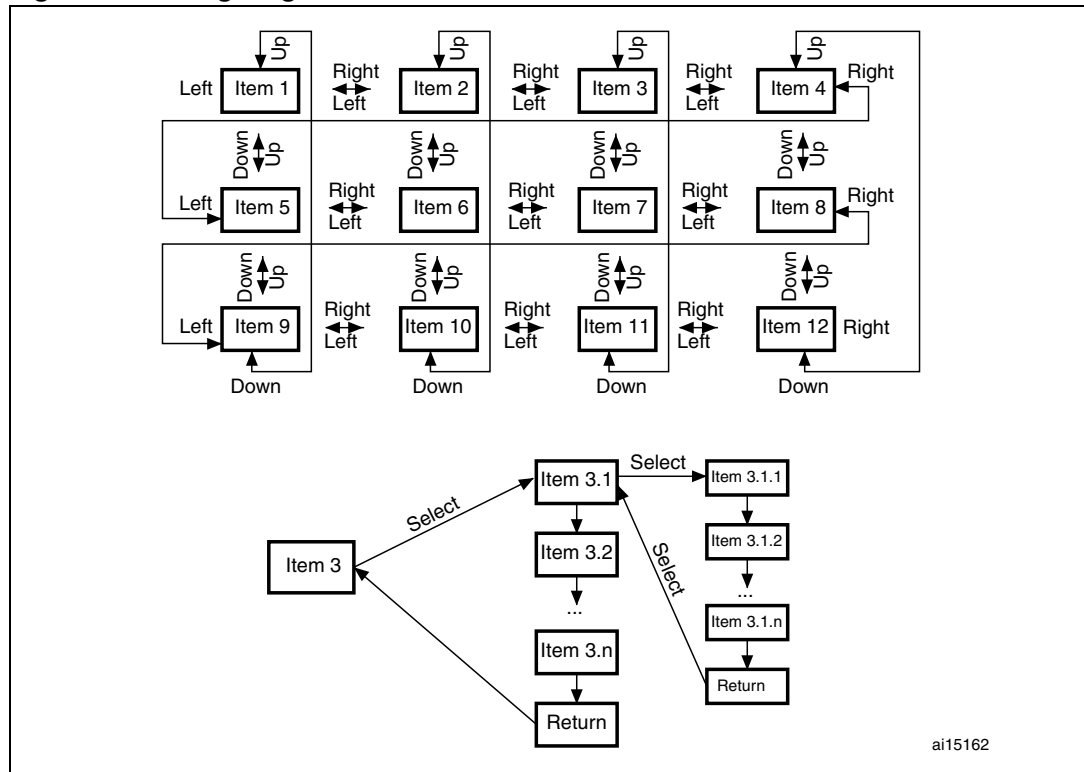

ai15162

## 2.5 Clock sources

### 2.5.1 Clock control

The STM32F100VB's internal clocks are derived from the HSE clocked by the external 8 MHz crystal.

In this demonstration application, the different system clocks are configured as follows:

- The system clock is set to 24 MHz. The PLL is used as the system clock source: 24 MHz.
- The HCLK frequency is set to 24 MHz
- The timer clock (TIMCLK) is set to 24 MHz
- The PCLK1 is set to 24 MHz
- The PCLK2 is set to 24 MHz

Only the RTC is clocked by a 32 kHz external oscillator.

*Figure 11* illustrates the clock tree organization for this demonstration.

Figure 11. Clock tree diagram

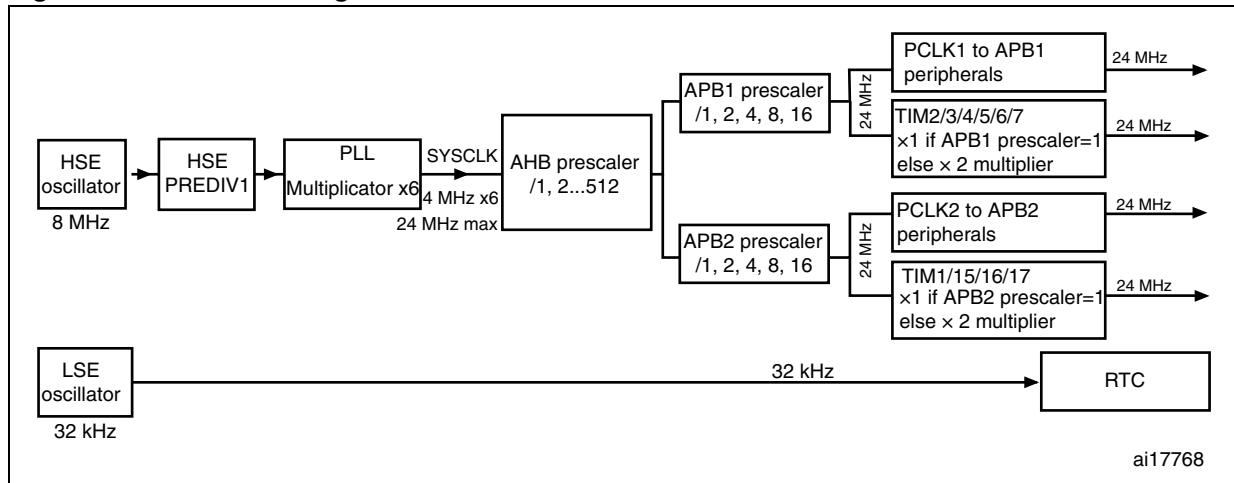

### 2.5.2 Clock failure

At any point of the demonstration, if no clock is present on OSC\_IN (broken or disconnected crystal), the message shown in [Figure 12](#) is displayed on the LCD screen.

Figure 12. No HSE clock detected

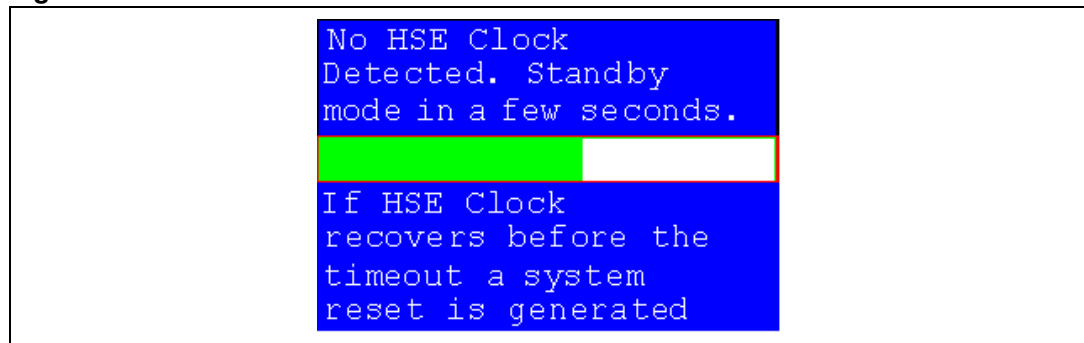

If no clock is detected, the clock security system (CSS) feeds the MCU with the HSI OSC used as an emergency clock.

The demonstration will not restart as long as the 8 MHz crystal is not present. You must connect the crystal before starting the demonstration. Connecting the 8 MHz crystal after reset may not restart the demonstration correctly.

If the 8 MHz crystal is not reconnected in the next few seconds, the MCU enters standby mode. If the 8 MHz crystal is reconnected within a few seconds, a system reset is generated.

When a timeout occurs, the MCU enters standby mode and the message shown in [Figure 13](#) is displayed on the LCD screen.

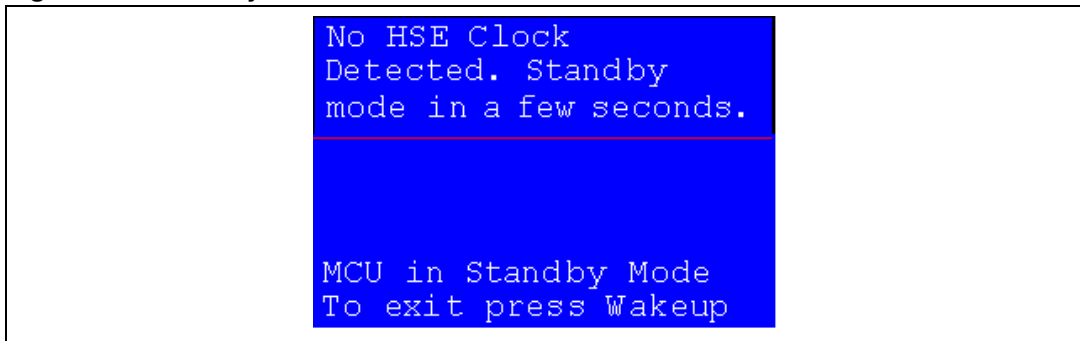

**Figure 13. Standby mode entered**

## 2.6 STM32F100VB resources

### 2.6.1 Peripherals

All used peripherals are described in [Table 1](#).

**Table 1. STM32F100VB demonstration peripherals**

| Used peripherals | Application  |
|------------------|--|
| I2C1             | Temperature sensor   |
| BKP              | Calendar + demo kernel                                     |
| EXTI             | Menu navigation + joystick + push button + low-power modes |
| GPIO             | All applications + LEDs                                    |
| NVIC             | All applications using interrupts                          |
| PWR              | Low-power modes  |
| RCC              | All applications + demo kernel                             |
| RTC              | Calendar   |
| SPI2             | Color LCD  |
| SysTick          | Generate 10 ms time base                                   |
| TIM1             | LED toggling   |
| DMA1             | Wave Player  |
| TIM6             | Wave Player  |
| DAC              | Wave Player  |
| SPI1             | MSD + SPI Flash  |
| ADC1             | IDD measure  |

## 2.6.2 Interrupts

*Table 2* shows all the enabled interrupts.

**Table 2. STM32F100VB demonstration interrupts**

| Interrupts | Priority                        | Used for              |
|------------|---------------------------------|-----------------------|
| SysTick    | Preemption: 0<br>SubPriority: 0 | System timing         |
| RTC        | Preemption: 0<br>SubPriority: 0 | Calendar, date update |
| NMI        | Preemption(fixed): -2           | CSS interrupt         |
| EXTI0      | Preemption: 2<br>SubPriority: 1 | Menu navigation       |
| EXTI9_5    | Preemption: 2<br>SubPriority: 1 | Menu navigation       |
| EXTI15_10  | Preemption: 2<br>SubPriority: 0 | Menu navigation       |
| I2C1 Error | Preemption: 0<br>SubPriority: 0 | SMBus Alert interrupt |
| TIM6_UP    | Preemption: 0<br>SubPriority: 1 | Sampling rate         |
| TIM1_UP    | Preemption: 1<br>SubPriority: 3 | LED toggling          |
| RTCAlarm   | Preemption: 1<br>SubPriority: 1 | Alarm generation      |
| CEC        | Preemption: 0<br>SubPriority: 0 | CEC transactions      |

### 2.6.3 External interrupts

**Table 3. STM32F100VB demonstration external interrupts**

| External interrupts | Used for                                     |
|---------------------|--|
| EXTI line14         | Joystick DOWN (interrupt mode, falling edge) |
| EXTI line8          | Joystick UP (interrupt mode, falling edge)   |
| EXTI line12         | Joystick SEL (interrupt mode, falling edge)  |
| EXTI line9          | User button (interrupt mode, falling edge)   |
| EXTI line13         | RTC alarm (interrupt mode, rising edge)      |

### 2.6.4 Internal memory organization

**Figure 14. Internal Flash memory organization**

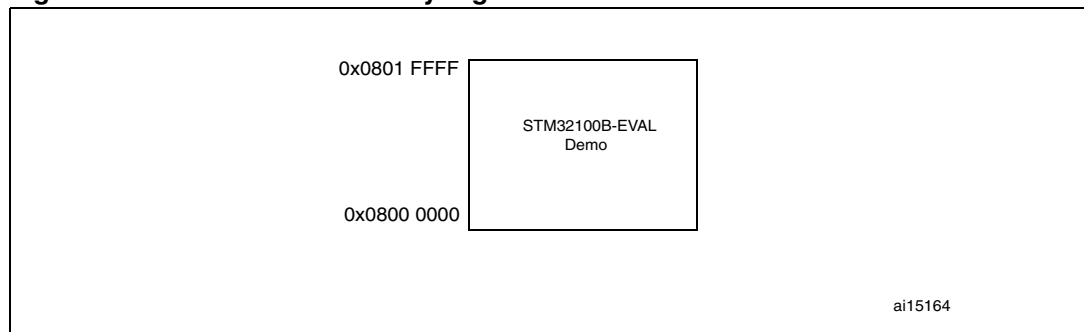

### 2.6.5 External memory organisation

The STM32100B-EVAL demonstration is based on an embedded free FAT file system, DosFs<sup>(1)</sup>. The file system is needed to read all media information from the on-board MicroSD memory card.

The SD card memory is organized in two sub directories:

- **STFILES:** this folder contains all needed demo media files (icons, wave and slides). User files located in this folder cannot be handled by the demonstration, only default files are managed. The STFILES directory and its internal files are mandatory for demonstration startup.
- **USER:** this is a user folder. You can add here your 16-bit bitmap images (320x240) and waves. This folder is used only by the Images Viewer and Wave Player submenus. For more details on the different files properties, please refer to [Section 2.7.3: Images Viewer submenu](#) and [Section 2.7.4: Wave Player submenu](#).

1. The DosFs is a FAT-compatible filesystem intended for fairly low-end embedded applications. It is not the leanest possible implementation (the leanest FAT implementations operate in << 512 bytes of RAM, with heavy restrictions). This code strikes a good balance between size and functionality, with an emphasis on RAM footprint. For more details, refer to the following link <http://www.larwe.com/zws/products/dosfs/index.html>.

Figure 15. MicroSD card organization

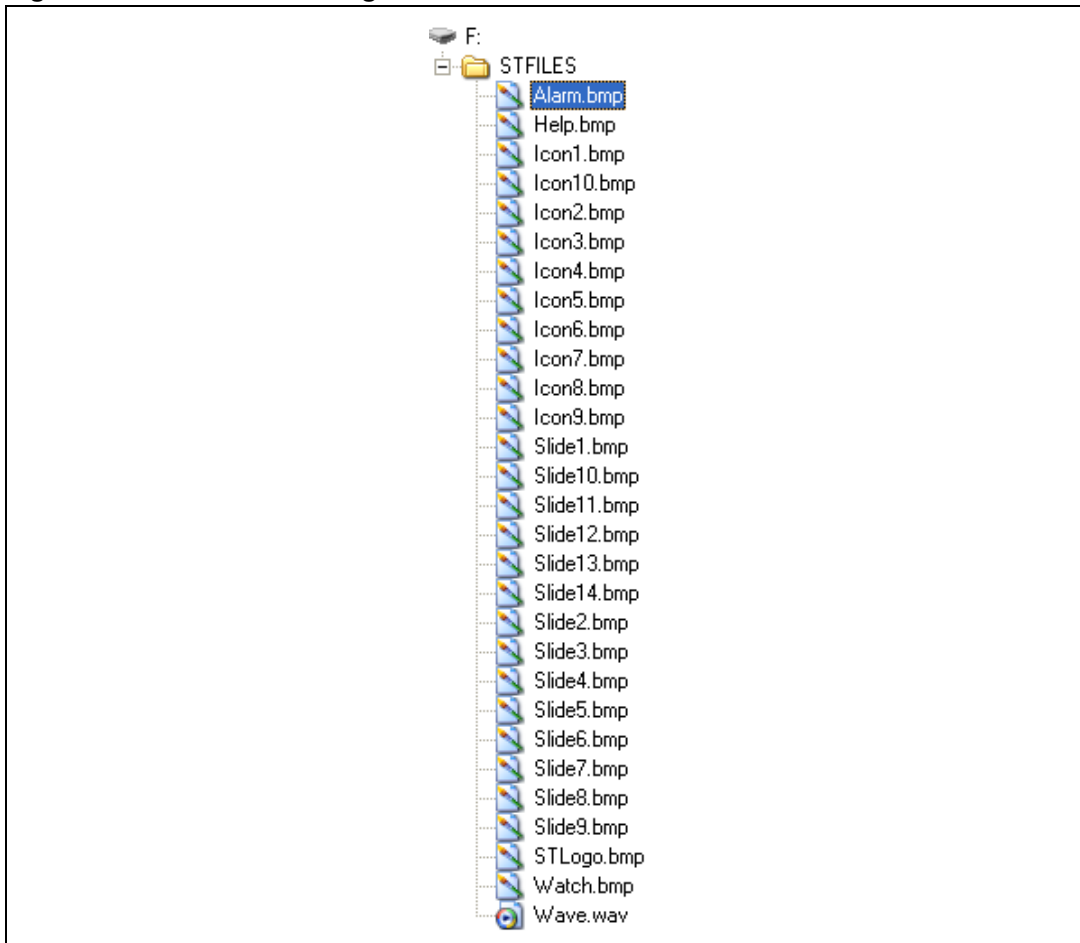

At any point of the demonstration, if the SD card is removed, the demonstration stops and the message shown in [Figure 16](#) is displayed on the LCD screen.

Figure 16. SDCard removal

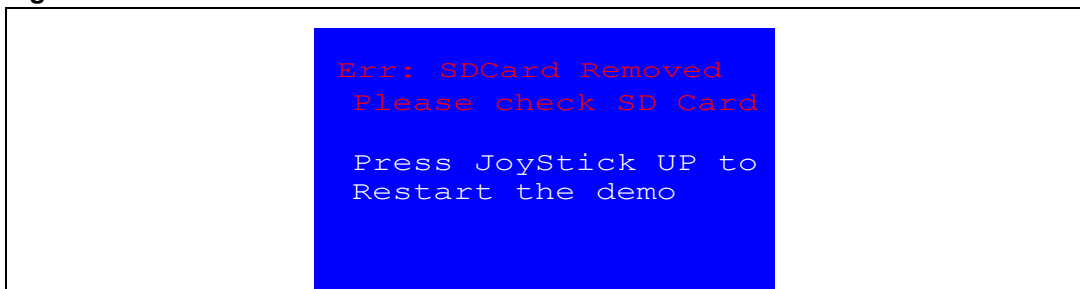

## 2.7 Demonstration applications

The following section provides a detailed description of each part of the demonstration.

In the demonstration, the core runs at HCLK = 24 MHz. Four LEDs: LD1, LD2, LD3 and LD4 flash throughout the demonstration at a frequency depending on the core clock.

### 2.7.1 Product presentation

This part of the demonstration presents all the STM32F100VB embedded peripherals and features. The product presentation is made with a slide show. Each slide is associated with a dedicated speech. When you start the product presentation, the first slide appears and the corresponding speech starts. Once the speech is finished, the second slide is displayed accompanied by its speech and so on until the last slide.

When the **Product presentation** menu is selected, the message shown in [Figure 17](#) is displayed on the LCD screen.

**Figure 17. Product presentation is ready to start**

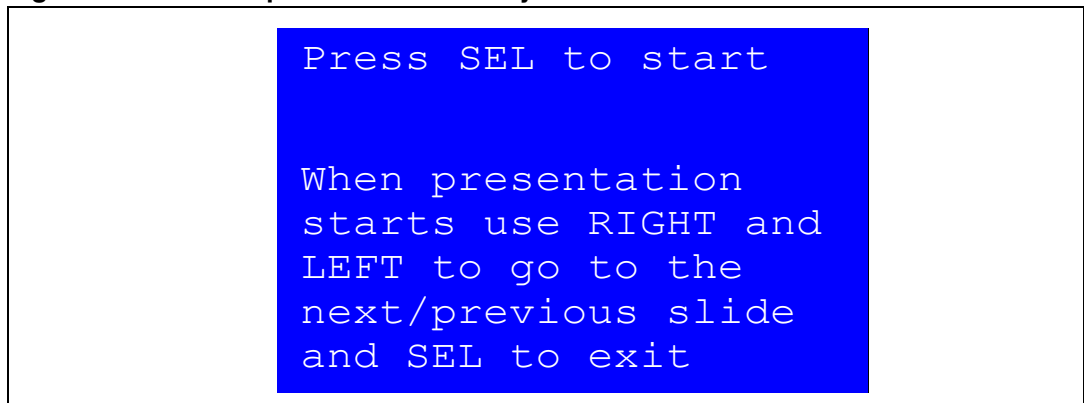

#### Product presentation slides

The presentation is composed of 14 slides where all features and advantages of the STM32F100VB are listed. [Figure 18](#) and [Figure 19](#) show the first and last slides, respectively.

**Figure 18. First presentation slide**



Figure 19. Last presentation slide



### Product presentation speech

The STM32100B-EVAL features an external audio amplifier used to play speech audio files through the embedded speaker or headphone.

The properties of the product presentation speech wave file are the following:

- Playing time: 6 min 16s
- File size: 3 014 752 bytes
- Format tag: PCM
- Channels: Mono
- Sample rate: 8 kHz
- Bits per sample: 8 bits

If the wave file of the promotion presentation speech is not loaded in the dedicated memory, the message shown in [Figure 20](#) is displayed on the LCD screen.

Figure 20. No loaded wave file

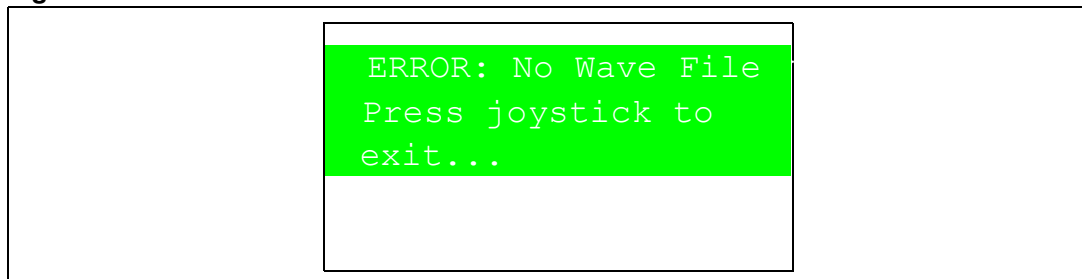

To stop the product presentation slide show and speech, push the SEL push-button. The message shown in [Figure 21](#) is displayed.

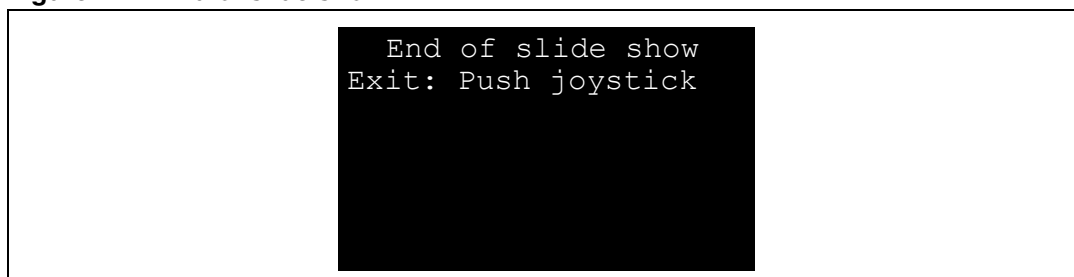
**Figure 21. End of slide show**

At the end of the product presentation or if the presentation was stopped, simply press any joystick key to exit and return to the **Product Presentation** submenu.

## 2.7.2 Calendar

The STM32F100VB features a real-time clock (RTC) that provides a set of continuously running counters. These can be used, with suitable software, to implement a clock-calendar function. The counter values can be written to set the current time of the system.

This submenu is used to configure the time, date and alarm. The date, time and alarm settings are not lost when the board is powered off owing to the battery connected to the  $V_{BAT}$  pin. The  $V_{BAT}$  pin supplies power to the RTC unit, allowing the RTC to operate even when the main digital supply ( $V_{DD}$ ) is turned off.

*Note:* To be able to use the battery to back up the RTC, the JP9 jumper must be in the position Battery-VDD on the STM32100B-EVAL board.

In any submenu, if the time and date parameters have not yet been configured, the message shown in [Figure 22](#) is displayed on the LCD screen.

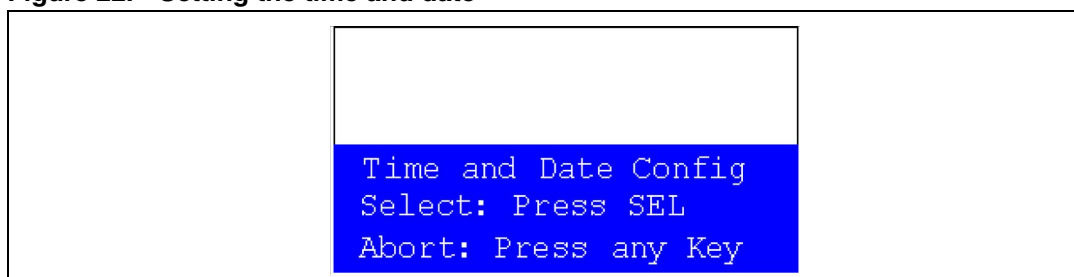
**Figure 22. Setting the time and date**

You have the choice to set or not the time, year, month and day. Press any key (except for SEL) to ignore the prompt and abort the configuration sequence. Press on SEL and follow the setting sequence to set the time and date.

### Time submenu

This submenu is divided into two items that allow you to display or set the current time:

- **Time Adjust:** after powering up the evaluation board, you can use this submenu to change the default time (00:00:00) to the current time.

To adjust the time:

1. Select **Time Adjust**. The message shown in *Figure 23* is displayed on the LCD. To modify the first digit of the hour field, use the UP and DOWN push-buttons. Press UP to display the current value plus one. Press DOWN to display the previous digit value.
2. After setting the digit value, press SEL. The cursor automatically jumps to the next digit.

When all the time digits have been set, the **Time** submenu appears. Some digit values are limited to a range of values depending on the field (hour, minute or seconds).

**Figure 23. Time Adjust submenu**



- **Time Show:** this item displays the current time. If time and date have not been previously configured, a message is displayed, that gives the choice to set the time and date or, to exit to the upper submenu. When this submenu is selected, the message shown in *Figure 24* appears on the LCD. In the example, the time has not been set yet.

**Figure 24. Time Show submenu**

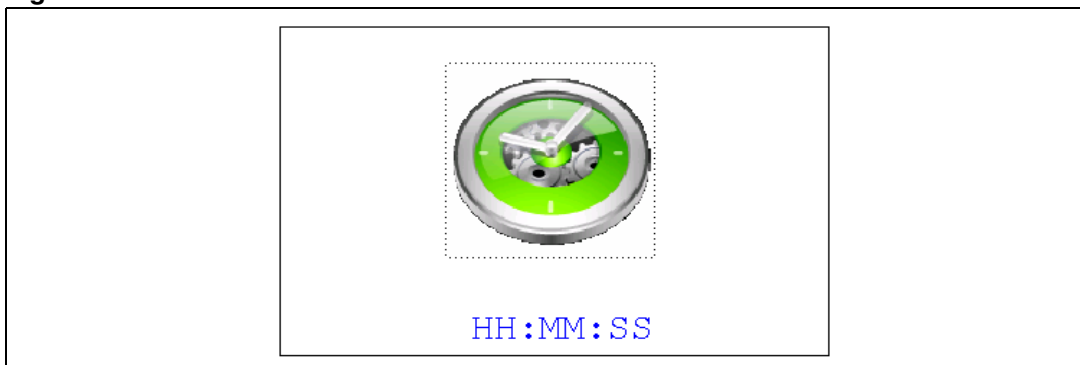

To exit the **Time Show** submenu, press the SEL push-button. To exit the **Time** submenu, select Return and press the SEL push-button.



**Date submenu**

This submenu is divided into two items that allow the user to display or set the current date.

- **Date Adjust:** this item has to be selected after each power-up in order to set the current date. If the time and date have not been previously configured, a message is displayed, that gives the choice to set the time and date or, to exit to the upper submenu. The date is displayed as: Year, Month, Week Nbr, Day Nbr (number of the day in the year) with the selected day shown in the month. There is no default date since you have to set the date at least once.

To adjust the date:

1. Start by selecting the year. To select the year, use the UP or DOWN push-buttons. Pressing the UP push-button displays the current value plus one, pressing the DOWN push-button displays the previous value. To confirm the selected year and continue to the month configuration, press the SEL push-button.

**Figure 25. Setting the year**

| Month    |    |    |    |    |    | Year    |
|----------|----|----|----|----|----|---------|
| Week Nbr |    |    |    |    |    | Day Nbr |
| Mo       | Tu | We | Th | Fr | Sa | Su      |
|          | 1  | 2  | 3  | 4  | 5  | 6       |
| 7        | 8  | 9  | 10 | 11 | 12 | 13      |
| 14       | 15 | 16 | 17 | 18 | 19 | 20      |
| 21       | 22 | 23 | 24 | 25 | 26 | 27      |
| 28       | 29 | 30 | 31 |    |    |         |

UP/DOWN: Set Year

2. Follow the same procedure to select the month and press the SEL push-button to confirm.

**Figure 26. Setting the month**

| Month    |    |    |    |    |    | Year    |
|----------|----|----|----|----|----|---------|
| Week Nbr |    |    |    |    |    | Day Nbr |
| Mo       | Tu | We | Th | Fr | Sa | Su      |
|          | 1  | 2  | 3  | 4  | 5  | 6       |
| 7        | 8  | 9  | 10 | 11 | 12 | 13      |
| 14       | 15 | 16 | 17 | 18 | 19 | 20      |
| 21       | 22 | 23 | 24 | 25 | 26 | 27      |
| 28       | 29 | 30 | 31 |    |    |         |

UP/DOWN: Set Month

3. To select the day, use the UP, DOWN, RIGHT and LEFT push-buttons. After configuring the day, press the SEL push-button to store the entered value and exit to the **Date** submenu.

The current date value is now displayed.

Figure 27. Setting the day of the month

| Month    |    |    |    |    |    | Year    |
|----------|----|----|----|----|----|---------|
| Week Nbr |    |    |    |    |    | Day Nbr |
| Mo       | Tu | We | Th | Fr | Sa | Su      |
|          | 1  | 2  | 3  | 4  | 5  | 6       |
| 7        | 8  | 9  | 10 | 11 | 12 | 13      |
| 14       | 15 | 16 | 17 | 18 | 19 | 20      |
| 21       | 22 | 23 | 24 | 25 | 26 | 27      |
| 28       | 29 | 30 | 31 |    |    |         |

All Key: Set Day

- **Date Show:** this item displays the current date. If the time and date have not been previously configured, the message shown in *Figure 28* is displayed. You have the choice to set the time/date or, to exit to the upper submenu.

Figure 28. Date Show submenu

| Month    |    |    |    |    |    | Year    |
|----------|----|----|----|----|----|---------|
| Week Nbr |    |    |    |    |    | Day Nbr |
| Mo       | Tu | We | Th | Fr | Sa | Su      |
|          | 1  | 2  | 3  | 4  | 5  | 6       |
| 7        | 8  | 9  | 10 | 11 | 12 | 13      |
| 14       | 15 | 16 | 17 | 18 | 19 | 20      |
| 21       | 22 | 23 | 24 | 25 | 26 | 27      |
| 28       | 29 | 30 | 31 |    |    |         |

To Exit Press SEL

To exit this submenu press the SEL push-button. To exit the **Date** submenu, select Return and press the SEL push-button.

### Alarm submenu

You can use this submenu to configure the alarm activation time. When the alarm time value is reached, all the LEDs (LED1 to LED4) start flashing simultaneously for 30 seconds. This submenu is divided into two items to display or set the current alarm.

- **Alarm Adjust:** the alarm time activation is set in the same way as in the **Time Adjust** submenu. The following messages are successively displayed on the LCD when this submenu is selected.

Figure 29. Setting the alarm activation time

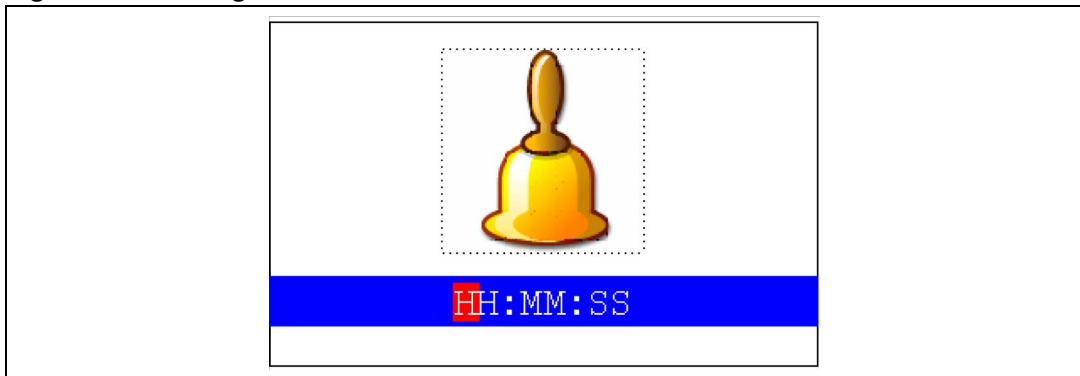

- **Alarm Show:** this item displays the current alarm time. The default alarm activation time displayed after powering up is 00:00:00. The message shown in [Figure 30](#) is displayed on the LCD when this submenu is selected.

Figure 30. Alarm Show submenu

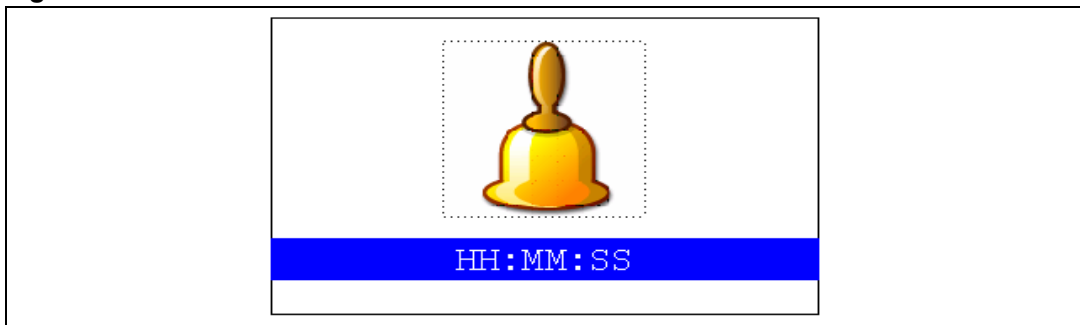

To exit the **Alarm Show** submenu press the SEL push-button. To exit the **Alarm** submenu, select Return and press the SEL push-button.

*Note:* In the **Alarm Adjust** and **Alarm Show** menus, if the time and date have not been previously configured, the message shown in [Figure 31](#) is displayed on the LCD screen.

Figure 31. Time and date not configured



### 2.7.3 Images Viewer submenu

The **Images Viewer** submenu is used to demonstrate the LCD control performance using the embedded SPI interface. The application displays successively the images stored on the MicroSD card.

This application reads all bitmap pictures from the USER directory (see [Section 4.1: Programming the media files](#)) and displays only the .BMP files having the following format:

- Bit depth: 16-bit (RGB)
- Size: 240x320

The maximum images number that can be read from the MicroSD card is 25 images selected by alphabetic order.

The **Images Viewer** submenu is shown in [Figure 32](#).

**Figure 32. Images Viewer submenu**

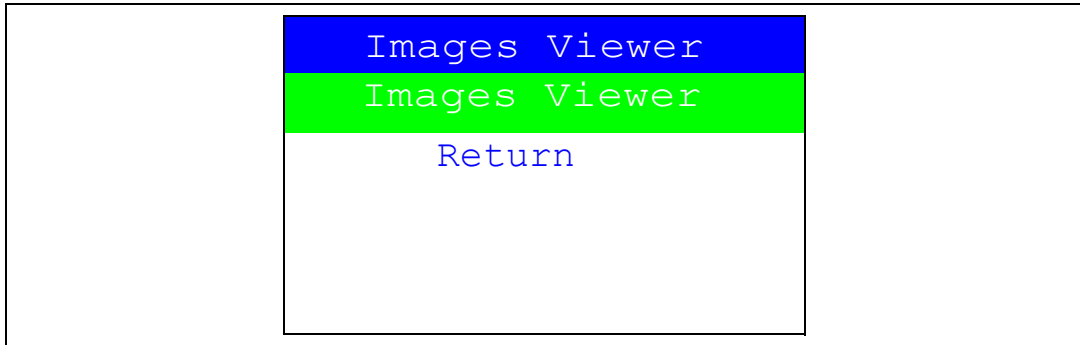

When you select **Images Viewer**, the first image is displayed as shown in [Figure 33](#).

**Figure 33. STM32 Images Viewer**



Use RIGHT and LEFT to go to the next/previous image stored in the USER folder of the MicroSD card. If you press the SEL push-button, the **Images Viewer** is stopped and you return to the **Images Viewer** submenu shown in [Figure 32](#).

### 2.7.4 Wave Player submenu

The STM32F100VB microcontroller features an embedded DAC which can be used to generate output signals.

In this demonstration, any wave file stored under the USER folder in the MicroSD card can be opened using the file system DOSFS and transferred to the internal SRAM by block (512 bytes) using the DMA and the SPI interface. Timer 6 (TIM6) triggers the DAC to generate

the wave signal. The voice sampling period is read from the Wave File Header. An audio amplifier is connected to the DAC interface to play the stored wave files. This application illustrates all STM32 DAC features and modes by dedicated examples and lists the configuration steps for each mode.

This application reads all wave files from the USER directory (see [Section 4.1: Programming the media files](#)) and displays only the .WAV files having the following format:

- Audio format: PCM (an uncompressed wave data format in which each value represents the amplitude of the signal at the time of sampling)
- Sample rate: may be 8000, 11025, 22050 or 44100 Hz
- Bits per sample: 8-bit (audio sample data values are in the range [0-255] )
- Number of channels: 1 (Mono)

The **Wave Player** submenu is shown in [Figure 34](#).

**Figure 34. Wave Player submenu**



When you select Wave Player, the wave player interface is displayed as shown in [Figure 35](#).

**Figure 35. Wave Player interface**

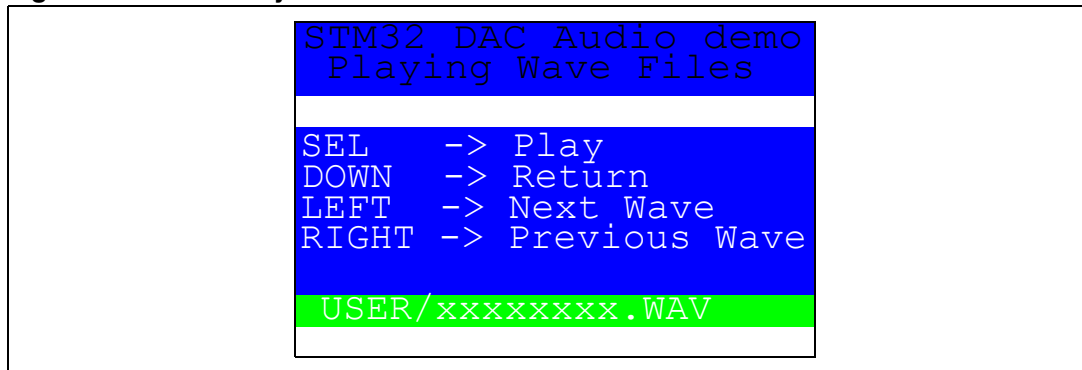

In [Figure 35](#), the active push-buttons and their functions are displayed. For example, at start-up, to play the file through the embedded speaker, press SEL. To exit the **Wave Player** submenu, press DOWN.

Once you select the play command, the submenu shown in [Figure 36](#) is displayed.

**Figure 36. Wave Player Playing submenu**



The progress bar and the volume bar are displayed at the bottom of the **Wave Player Playing** submenu. The progress bar is updated about every 1% of the audio file duration and the volume bar is updated each time the volume level is changed.

At this application level:

- Press the SEL push-button to pause the audio stream
- Press the LEFT push-button to decrement the audio stream
- Press the RIGHT push-button to increment the audio stream
- Press the DOWN push-button to exit the wave player submenu

When the audio stream is paused, the menu in [Figure 37](#) is displayed.

**Figure 37. Pause submenu**

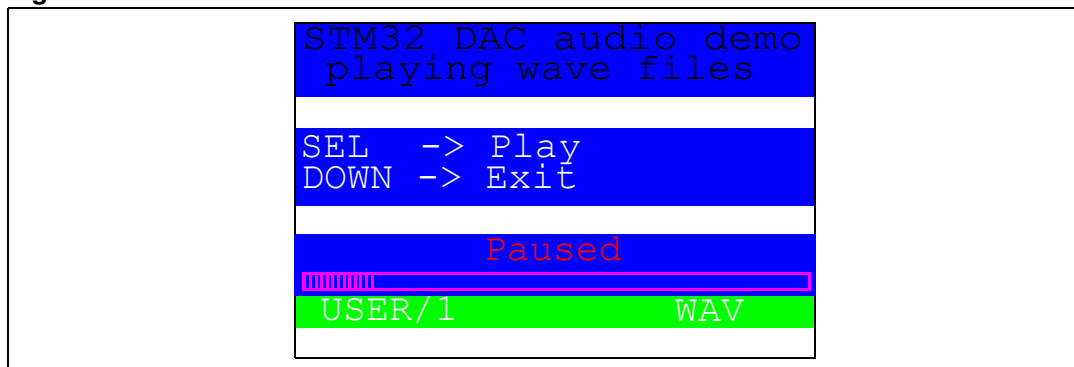

To resume playing, press the SEL push-button to return to the **Wave Player Playing** submenu as shown in [Figure 36](#).

When the audio stream is stopped, the stream position is reset and you return to the Wave Player interface menu shown in [Figure 35](#).

### 2.7.5 Low-power modes

The STM32F100VB microcontroller features several operating modes in which the power consumption is reduced. The purpose of this menu is to demonstrate the behavior of the microcontroller in different low-power modes. The Stop and Standby modes are taken as examples.

### Stop mode menu

This menu allows you to put the STM32F100VB in Stop mode. The software performs the specific instruction sequence needed to enter Stop mode.

**Figure 38. Stop mode menu**

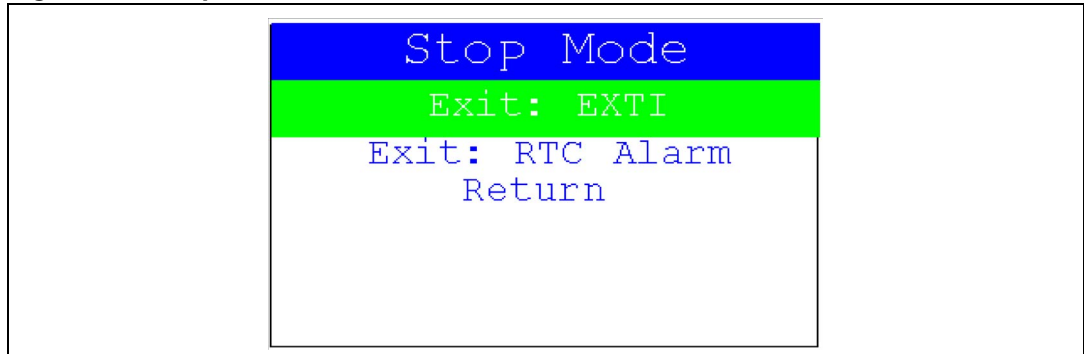

There are two ways to make the STM32F100VB exit Stop mode.

- In the first case, you can use the EXTI Key button. Once the **Stop mode** submenu has been selected, the red LEDs continue blinking until the SEL push-button is pressed, and the system enters Stop mode. When the MCU is in Stop mode, the message shown in [Figure 39](#) is displayed on the LCD.

**Figure 39. Stop mode entered**

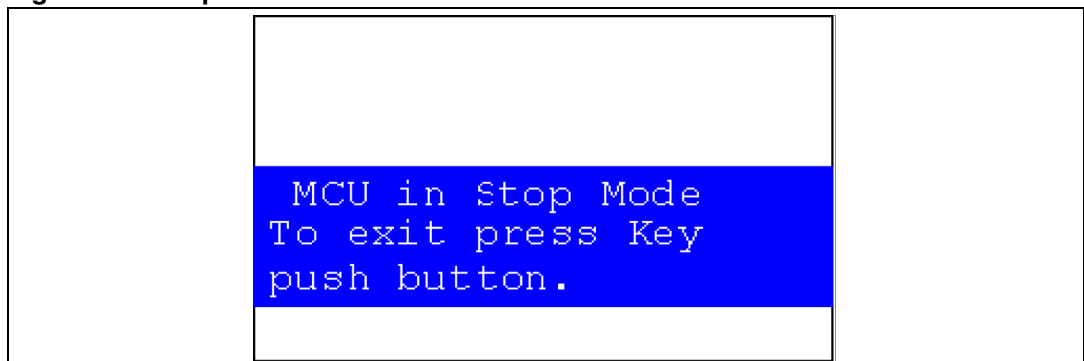

The MCU remains in Stop mode until the Key push-button is pressed as shown in [Figure 40](#). Once you press the Key push-button, the MCU exits Stop mode. The system clock is then set to 24 MHz and the application resumes execution.

**Figure 40. MCU in Stop mode**

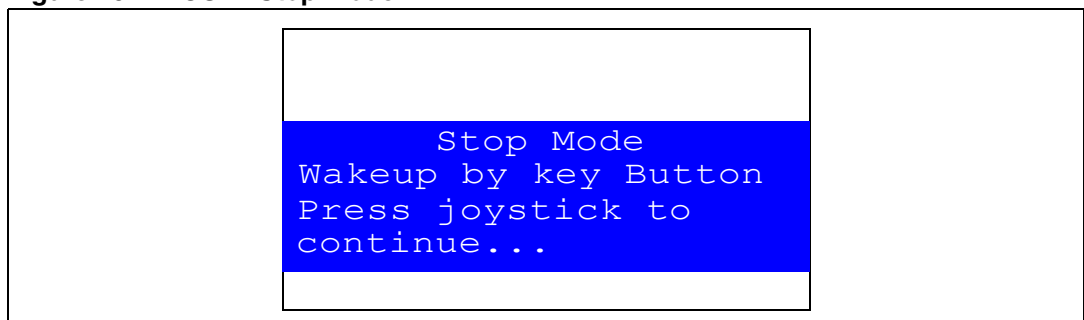

*Note:* If an RTC Alarm is generated while the MCU is in Stop mode and the message shown in [Figure 40](#) is displayed (which means that the Key push-button needs to be pressed to exit the Stop mode), the RTC Alarm causes the MCU to exit Stop mode. The message shown in [Figure 41](#) is then displayed.

**Figure 41. RTC Alarm causes the MCU to exit the Stop mode**

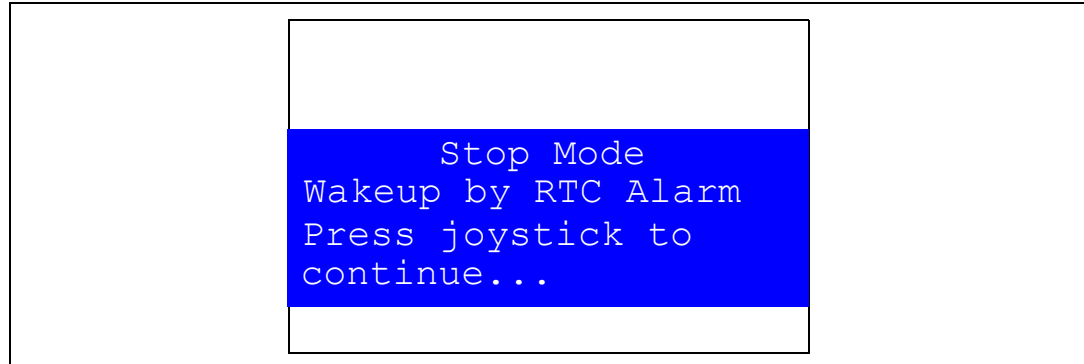

- In the second case, the RTC Alarm wakes up the MCU from Stop mode after the programmed time has elapsed. When selecting this submenu, you have to set the alarm to the time when the MCU is to exit Stop mode. To set the wakeup time, follow the procedure explained in section [Time submenu](#).

**Figure 42. Setting the wakeup time**

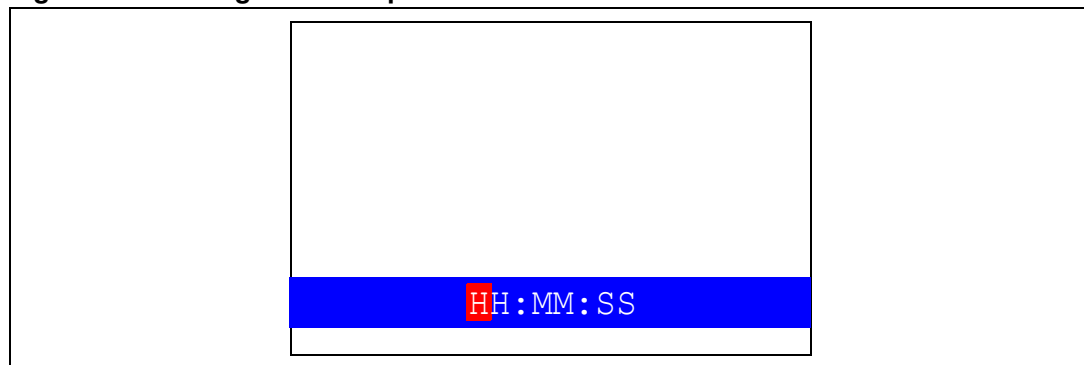

Once the alarm has been configured, the red LEDs stop blinking and the system enters Stop mode. The message shown in [Figure 43](#) is displayed on the LCD.

**Figure 43. RTC Alarm wakeup configured**

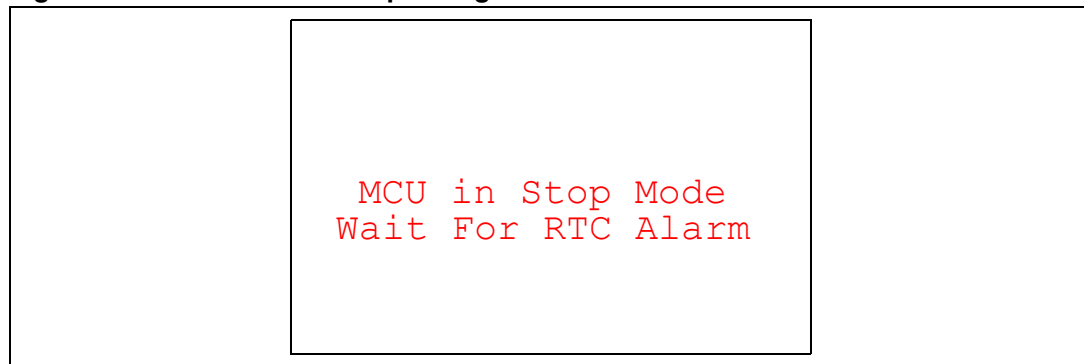



After the programmed time has elapsed, the system exits Stop mode. The system clock is then set to 24 MHz and the application resumes execution. The message shown in [Figure 44](#) is displayed on the LCD screen.

**Figure 44. RTC Alarm wakeup**

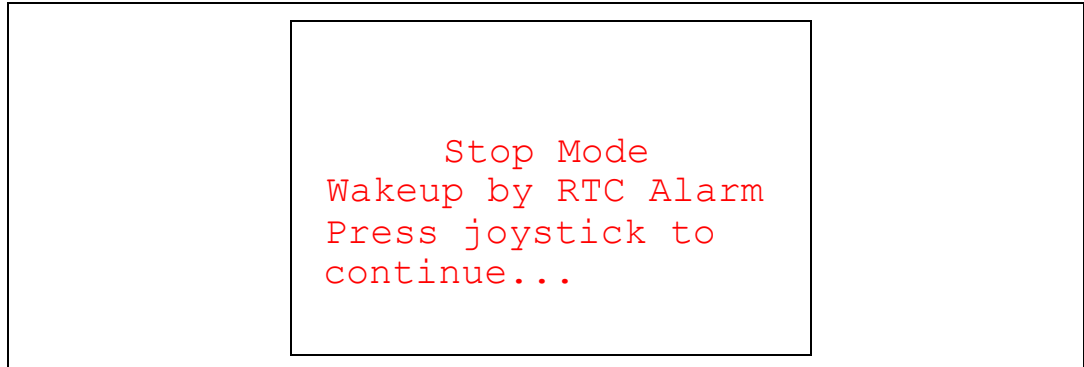

*Note:* If the time and date have not been set, the message shown in [Figure 45](#) is displayed on the LCD screen.

**Figure 45. Time and Date configuration prompt**

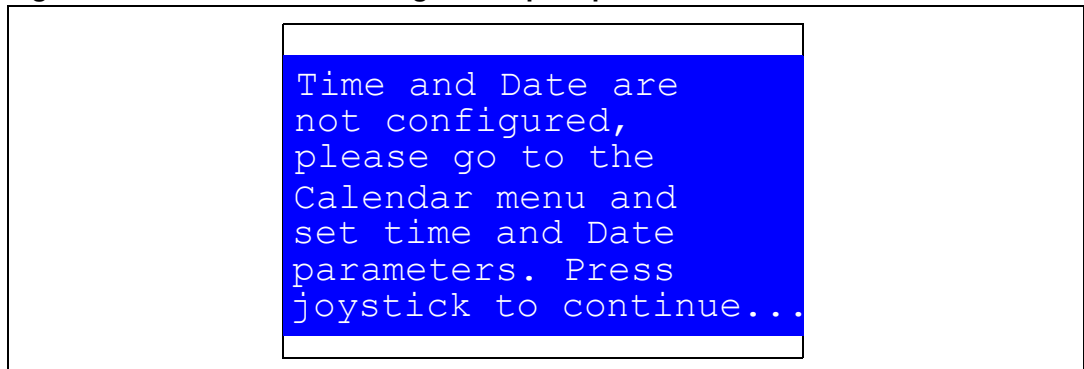

### Standby mode menu

This menu allows the user to put the STM32F100VB in Standby mode. The software runs the specific instruction sequence needed by the STM32F100VB to enter Standby mode.

**Figure 46. Entering Standby mode**

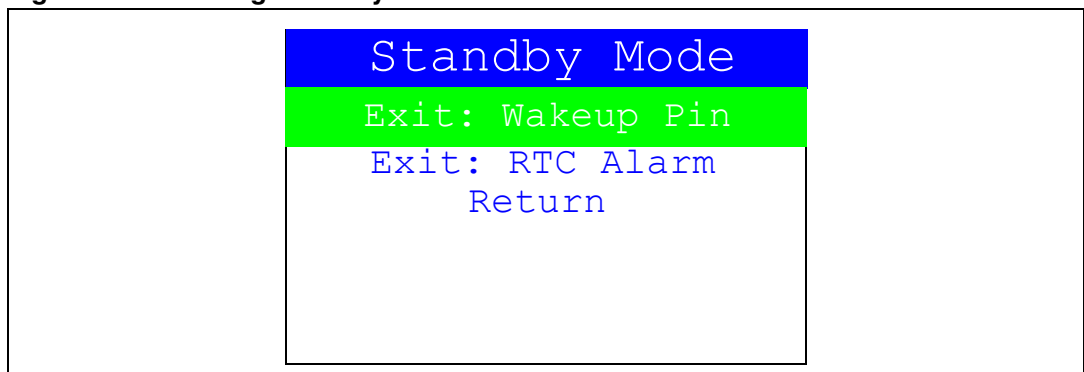

There are two ways to make the STM32F100VB exit Standby mode.

- In the first case, you can use the Wakeup push-button. Once the **Standby mode** submenu has been selected, the red LEDs continue blinking until you press the “SEL” push-button, and the system enters Standby mode. When the MCU is in Standby mode, the message shown in [Figure 47](#) is displayed on the LCD.

**Figure 47. MCU in Standby mode**

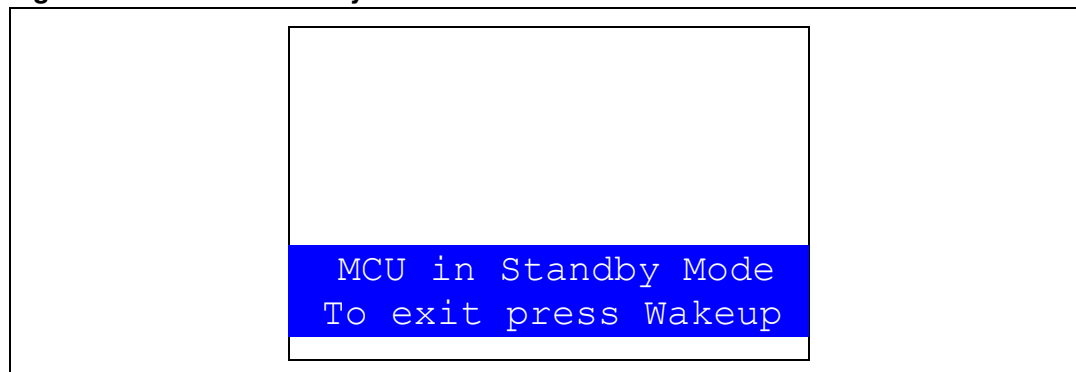

The MCU remains in Standby mode until the Wakeup push-button is pressed. Once you press the Wakeup push-button, the MCU exits Standby mode and the system reset signal is generated.

*Note: If an RTC Alarm is generated while the MCU is in Standby mode and the message shown in [Figure 47](#) is displayed (which means that the Wakeup push-button needs to be pressed to exit the Standby mode), the RTC Alarm causes the MCU to exit the Standby mode and a system reset signal is generated.*

**Figure 48. RTC Alarm causes the MCU to exit Standby mode**

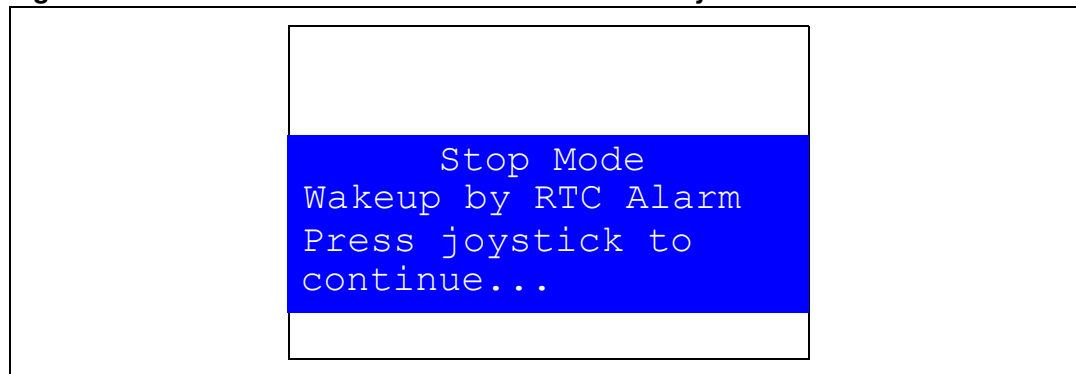

- In the second case, the RTC Alarm wakes up the MCU from Standby mode after the programmed time has elapsed. When selecting this submenu, you have to set the alarm to the time when the MCU is to exit Standby mode. To set the wakeup time, follow the procedure explained in the section [Time submenu](#).

**Figure 49. Setting the wakeup time**

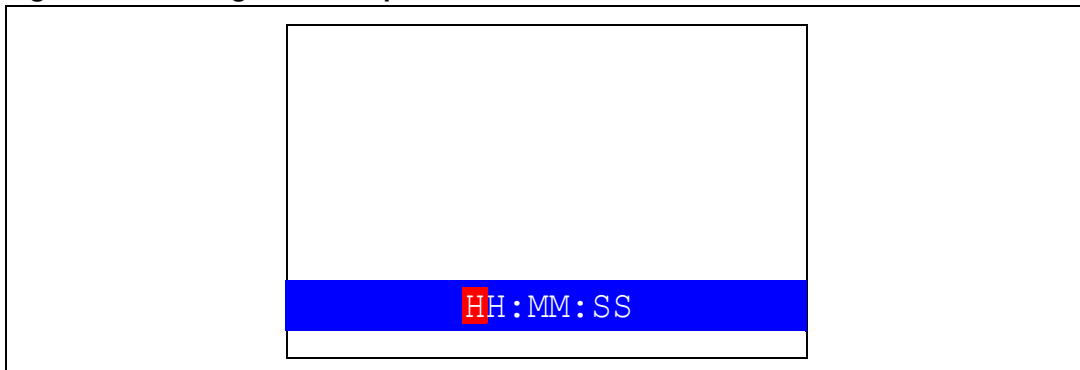

Once the alarm has been configured, the red LEDs stop blinking and the system enters Standby mode. The message shown in [Figure 50](#) is then displayed on the LCD.

**Figure 50. RTC Alarm wakeup configured**

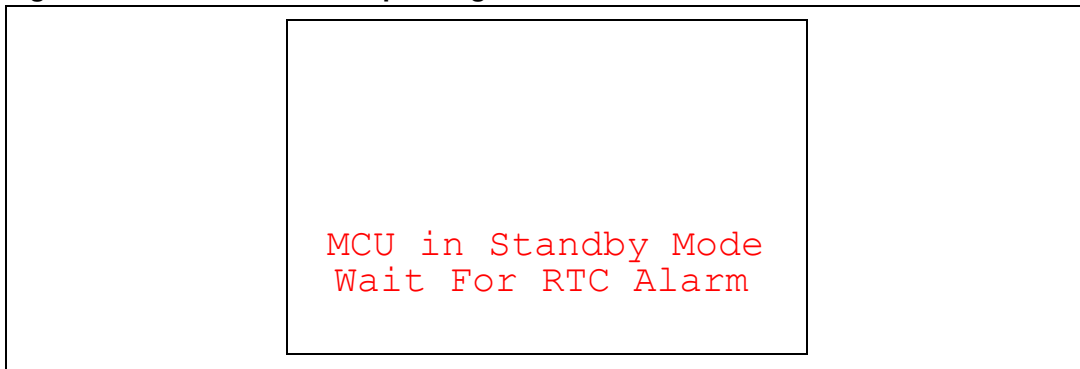

After the programmed timing has elapsed, the system exits Standby mode and a system reset signal is generated.

*Note:* If the time and date have not been set, the message shown in [Figure 51](#) is displayed on the LCD screen.

**Figure 51. Time and Date configuration prompt**

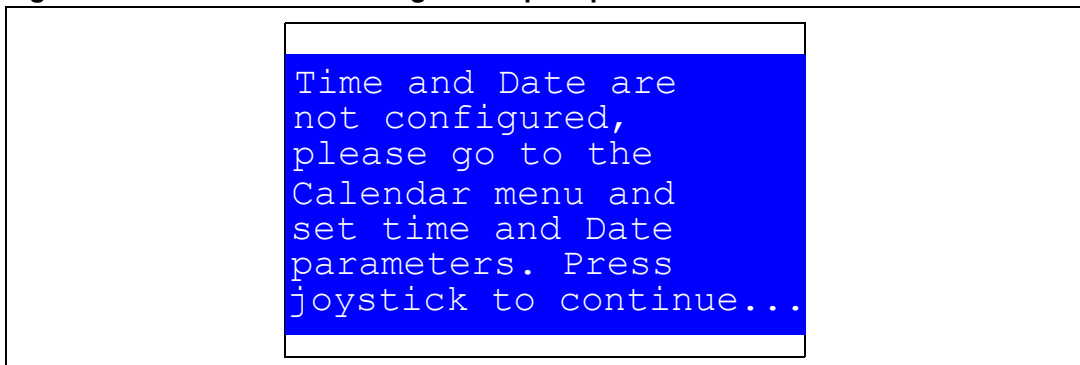

### 2.7.6 IDD Measure menu

The STM32F100VB microcontroller features an ADC peripheral. It measures the  $I_{DD}$  current in Run, Sleep and Stop mode by using the  $I_{DD}$  measurement circuit available on the STM32100B-EVAL board.

To select the  **$I_{DD}$  Measure** menu, press SEL from the main menu. The message shown in [Figure 52](#) is then displayed on the LCD screen.

**Figure 52.  $I_{DD}$  Measure menu**

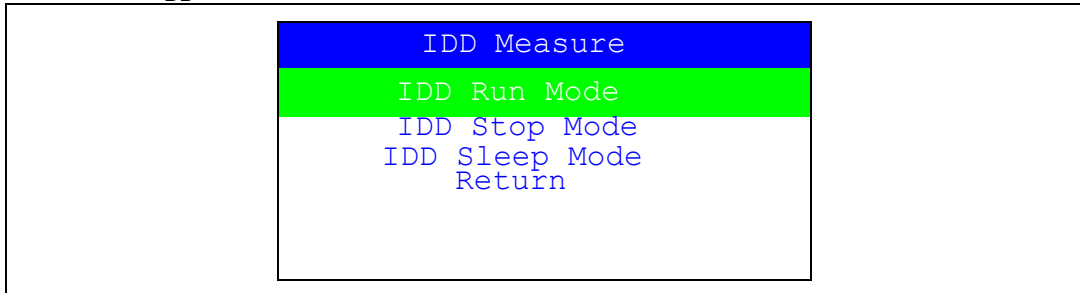

If you select the  **$I_{DD}$  Run mode** submenu, the message shown in [Figure 53](#) is displayed.

**Figure 53.  $I_{DD}$  Run mode menu**

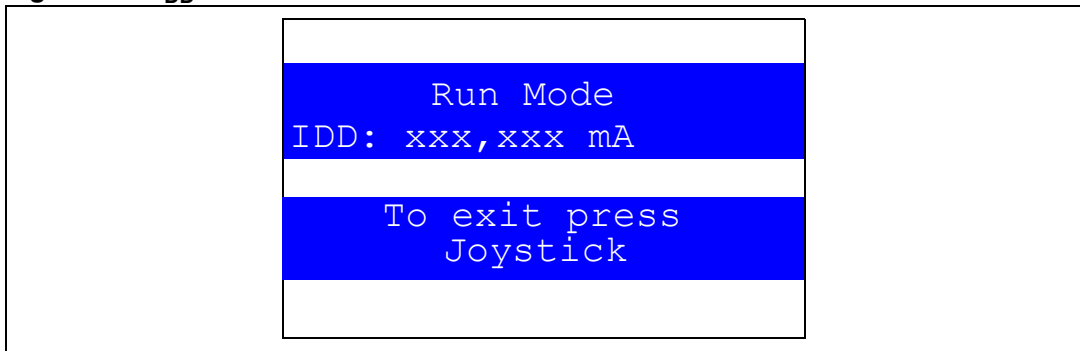

The  $I_{DD}$  value is periodically refreshed, until the joystick push-button is pressed. Once the joystick push-button is pressed, the MCU exits the  **$I_{DD}$  Run Mode** submenu and returns to the  **$I_{DD}$  Measure** menu as shown in [Figure 52](#). If you select the  **$I_{DD}$  Stop mode** submenu, the message shown in [Figure 54](#) is displayed.

**Figure 54.  $I_{DD}$  Stop mode menu**

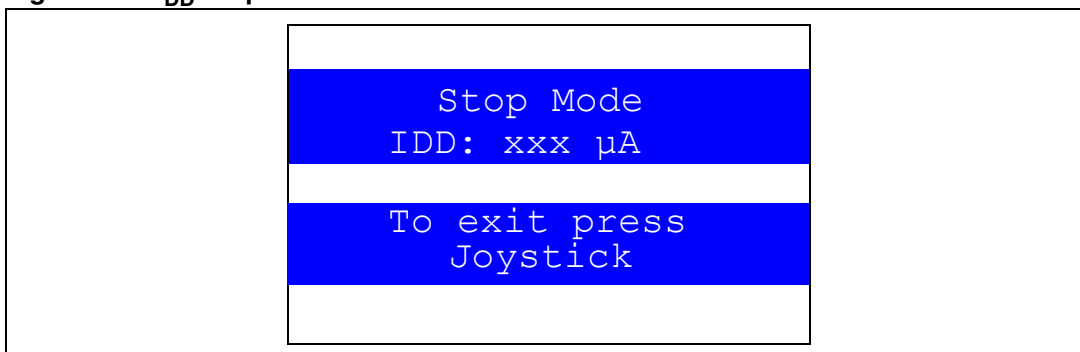

The value of  $I_{DD}$  current in Stop mode is evaluated and displayed on LCD and the demonstration keeps waiting until the joystick push-button is pressed. Once you press the joystick push-button, the MCU exits the  **$I_{DD}$  Stop Mode** submenu and returns to the  **$I_{DD}$  Measure** menu as shown in [Figure 52](#).

*Note:* When the STOP mode is entered, all GPIO are configured as analog inputs and the SRAM and the Flash memory interface clocks are stopped.

If you select the  **$I_{DD}$  Sleep mode** submenu, the message shown in [Figure 55](#) is displayed.

**Figure 55.  $I_{DD}$  Sleep mode menu**

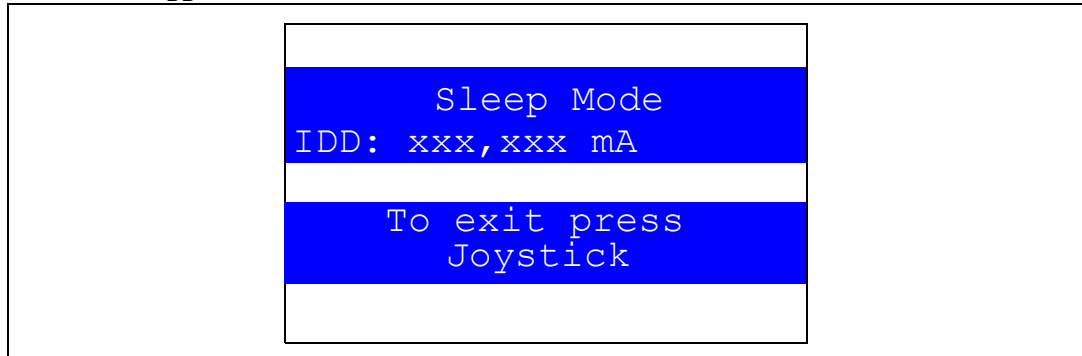

The value of the  $I_{DD}$  current in Sleep mode is evaluated and displayed on LCD and the demonstration keeps waiting until the joystick push-button is pressed. Once the joystick push-button has been pressed, the MCU exits the  **$I_{DD}$  Sleep Mode** submenu and returns to the  $I_{DD}$  Measure mode menu as shown in [Figure 52](#).

When the Sleep mode is entered, the SRAM and the Flash interface clocks are stopped.

*Note:* Make sure that the JP8 jumper is installed in the  $I_{DD}$  position before running the  $I_{DD}$  measurement demonstration.

### 2.7.7 Thermometer

The STM32F100VB microcontroller has two embedded  $I^2C$  peripherals that can be connected to any device supporting the  $I^2C$  protocol including the system management bus (SMBus) mode. An STLM75 (or a compatible device)  $I^2C$  temperature sensor is mounted on the STM32100B-EVAL board and used to get instantaneous external temperature (-55°C to +125°C).

When the **Thermometer** submenu is selected, the message shown in [Figure 56](#) is displayed on the LCD.

Figure 56. Thermometer submenu selected

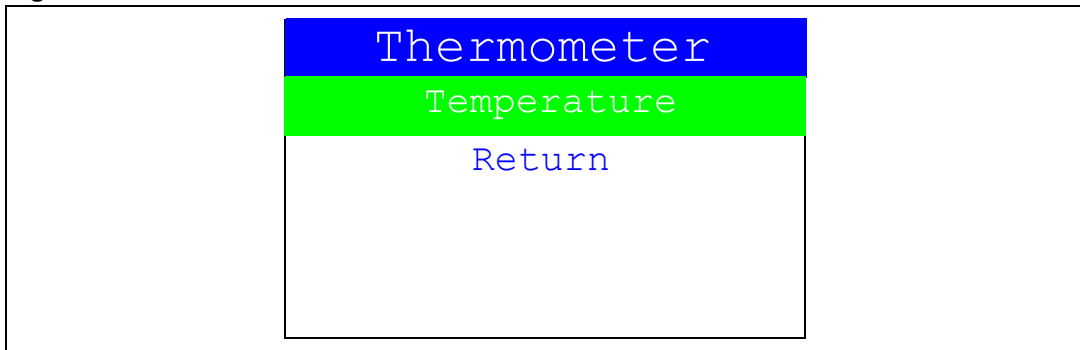

Once you select the **Temperature** submenu, the temperature value is displayed in Celsius and Fahrenheit as shown in [Figure 57](#).

Press any key to return to the **Thermometer** submenu.

Figure 57. Temperature display

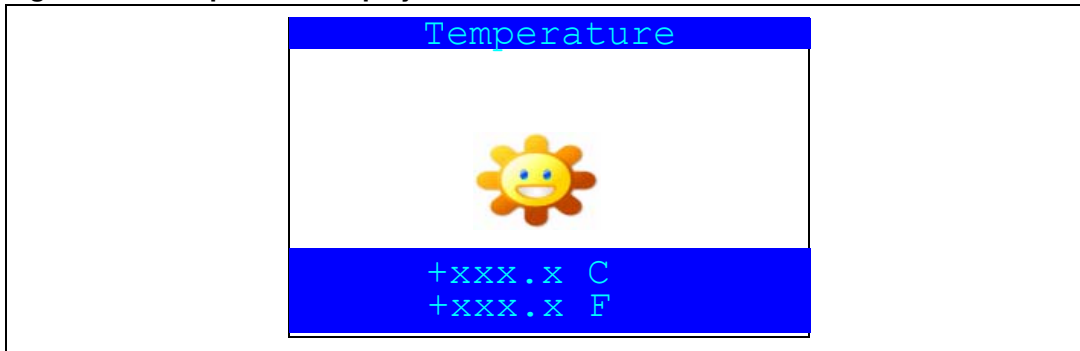

Thanks to STM32 I2C SMBus feature, we can easily monitor the temperature variations. This is managed by the SMBus Alert which generates a dedicated interrupt to inform the system that the temperature is out of the selected range. This can be very useful for systems where the increase of temperature needs an immediate intervention, like in motor control, medical systems, etc.

If the temperature exceeds the over-limit high value (TEMPERATURE\_TOS: Over Limit Temperature), the SMBus Alert interrupt is generated and the following warning message is displayed on the LCD screen:

Figure 58. Warning temperature display

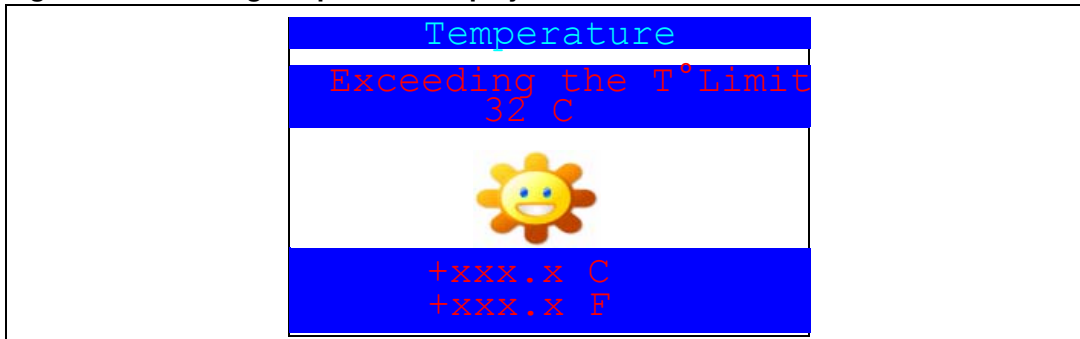

The message shown in [Figure 58](#) is displayed on the LCD when the temperature goes under the over-limit low value (TEMPERATURE\_THYS: Hysteresis Temperature).

You can configure the TOS and THYS thanks to dedicated `#define` statements in the code. By default they are set to (see `menu.c` file):

```
#define TEMPERATURE_THYS 31
#define TEMPERATURE_TOS 32
```

Press any key to return to the **Thermometer** submenu.

*Note:* Any hardware trouble with the temperature sensor is detected by a test. In this event, the message shown in [Figure 59](#) is displayed.

**Figure 59. Temperature sensor error**

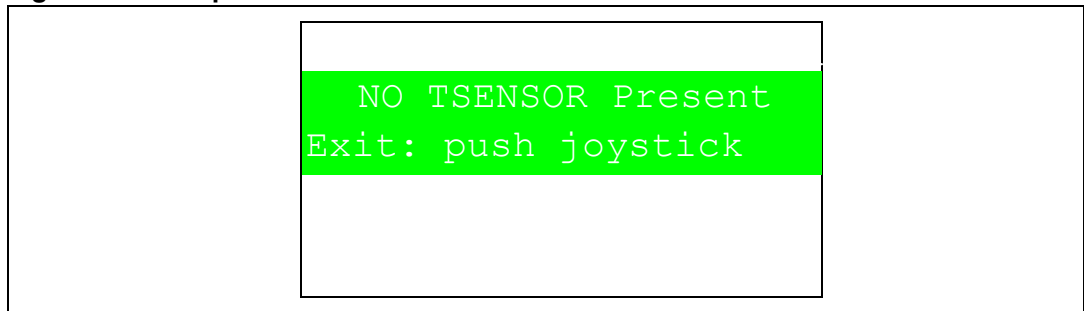

## 2.7.8 HDMI™ CEC submenu

The STM32F100VB microcontroller features an HDMI-CEC peripheral, this demonstration shows how to configure this peripheral and how to create CEC network providing a high level communication between different devices using CEC protocol messages.

For more details, refer to application note AN3127: "CEC networking using STM32F100xx value line microcontrollers". This application note provides a full description of the STM32F100xx value line embedded HDMI-CEC Controller and a step by step firmware description of CEC peripheral configuration. An advanced demonstration firmware communicating in a real multimedia and HDMI environment is also provided to build easily the CEC applications.

When the **HDMI CEC** submenu is selected, the message shown in [Figure 60](#) is displayed on the LCD.

**Figure 60. HDMI CEC submenu selected**

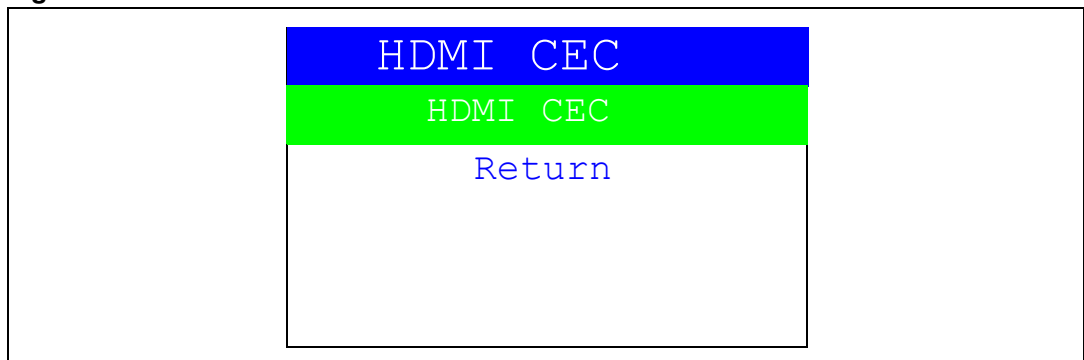

Once you select the **HDMI CEC** submenu, if no CEC error is generated, the device is configured as Tuner and the physical and logical addresses are displayed on the LCD as shown in *Figure 61*. To enter the CEC menu, press the SEL push-button.

**Figure 61. HDMI CEC configuration submenu**

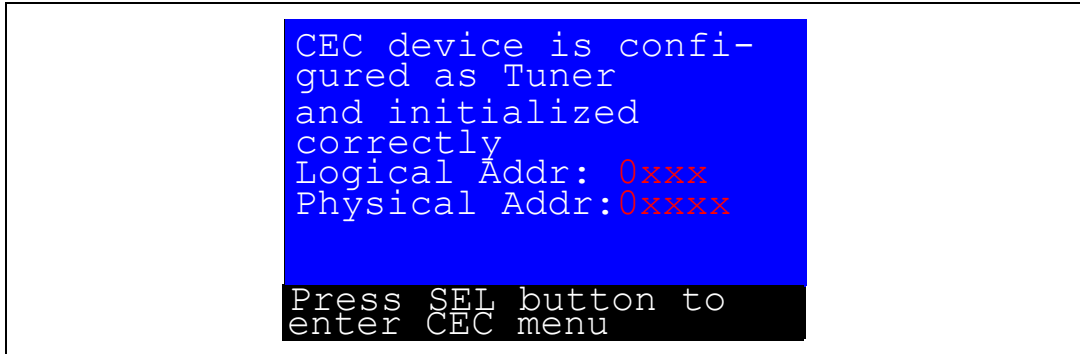

The LCD screen is divided into two parts as shown in *Figure 62*:

- a subscreen that shows the CEC receive information: receive status, sender address
- a subscreen that allows to select the follower address and the command to send

**Figure 62. CEC menu**



After selecting the follower address, select the command to be send to the selected follower address using the LEFT, RIGHT and SEL buttons. After selecting the command, the CEC device sends this command to selected follower address and displays the status of transmission as shown in *Figure 63*.

You can select again a new follower address and a new command.

**Figure 63. Select CEC command**

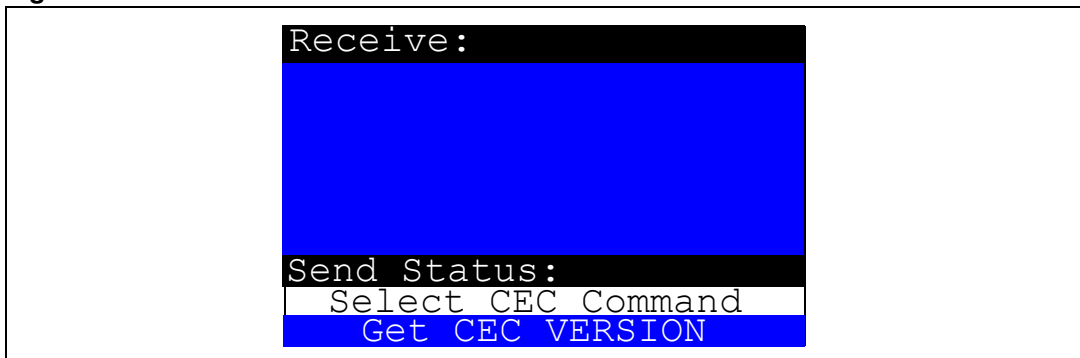



When receiving a new message, the following information can be displayed on the LCD:

- Receive status
- Sender address
- Number of bytes (including the sender address)
- Opcode message
- Data (operands)

*Figure 64* shows that the device has correctly received the frame from the sender with address: 0x5, number of bytes received: 0x3 (header + opcode + data), message opcode: 0x44 and data: 0x41

**Figure 64. Receive subscreen information**

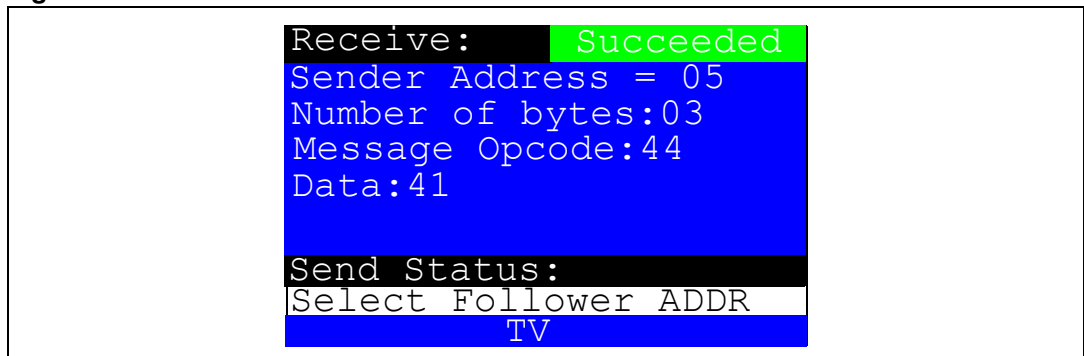

Any time in the CEC application, If you press the KEY push-button, the HDMI CEC stops and you return to the HDMI CEC submenu shown in *Figure 60*.

*Note:* The STM32100B CEC device responds only to the following commands. For other commands it sends feature abort:

- Standby
- Get CEC version
- Give physical address
- Give OSD name

### 2.7.9 Help submenu

This submenu provides help on the different keys used in the STM32F100VB demonstration. When this submenu is selected, the message shown in *Figure 65* is displayed on the LCD screen.

Figure 65. Help submenu

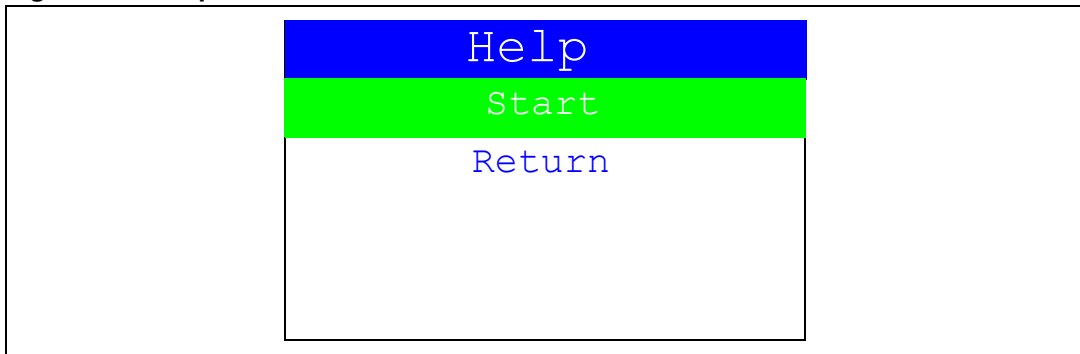

If you press SEL, the image shown in *Figure 66* is displayed on the LCD screen.

Figure 66. Joystick buttons

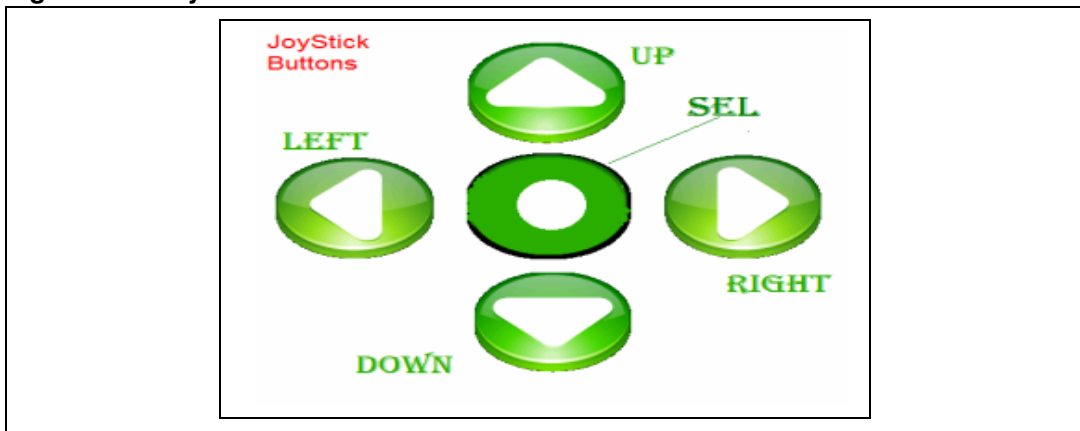

Press any joystick push-button to display the next help slide as shown in *Figure 67*.

Figure 67. Second help slide

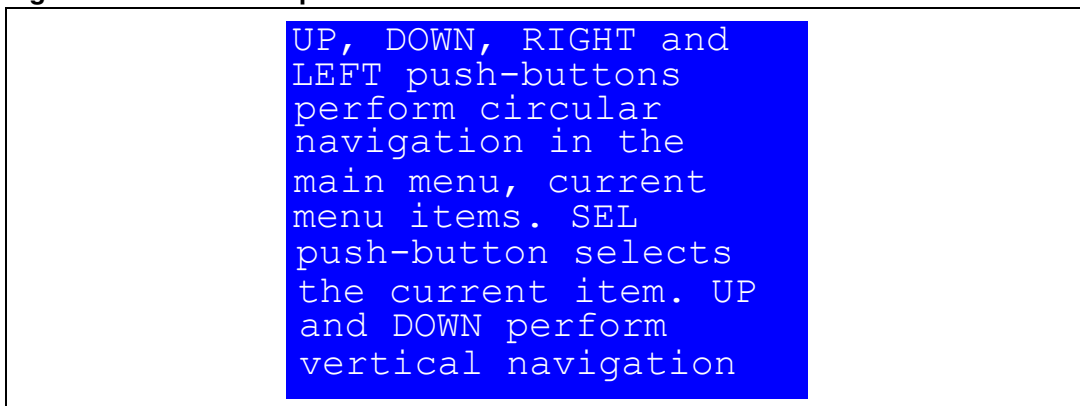

Press the joystick to exit the slide and return to the **Help** submenu.

### 2.7.10 About submenu

This submenu shows the version of the STM32F100VB demonstration software. When the **About** submenu is selected, the message shown in [Figure 68](#) is displayed on the LCD screen.

**Figure 68. About submenu**

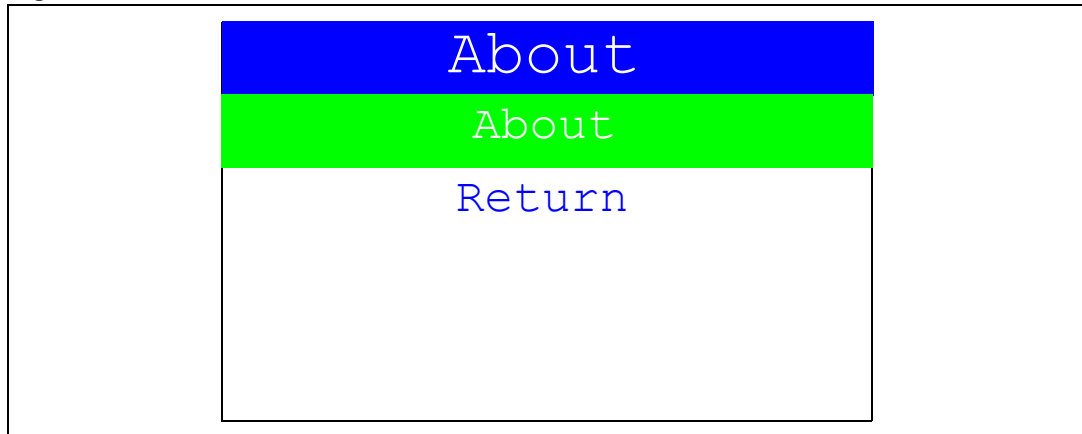

Pressing SEL displays a message showing the STM32100B-EVAL demonstration version on the LCD screen.

### 3 STM32100B-EVAL demonstration package

The STM32100B-EVAL demonstration is supplied in one single zip file. The extraction of the zip file generates one folder, *STM32100B-EVAL\_FW\_VX.Y.Z*, which contains the subfolders shown in [Figure 69](#) and described below.

**Figure 69. STM32100B-EVAL demonstration package directory tree**

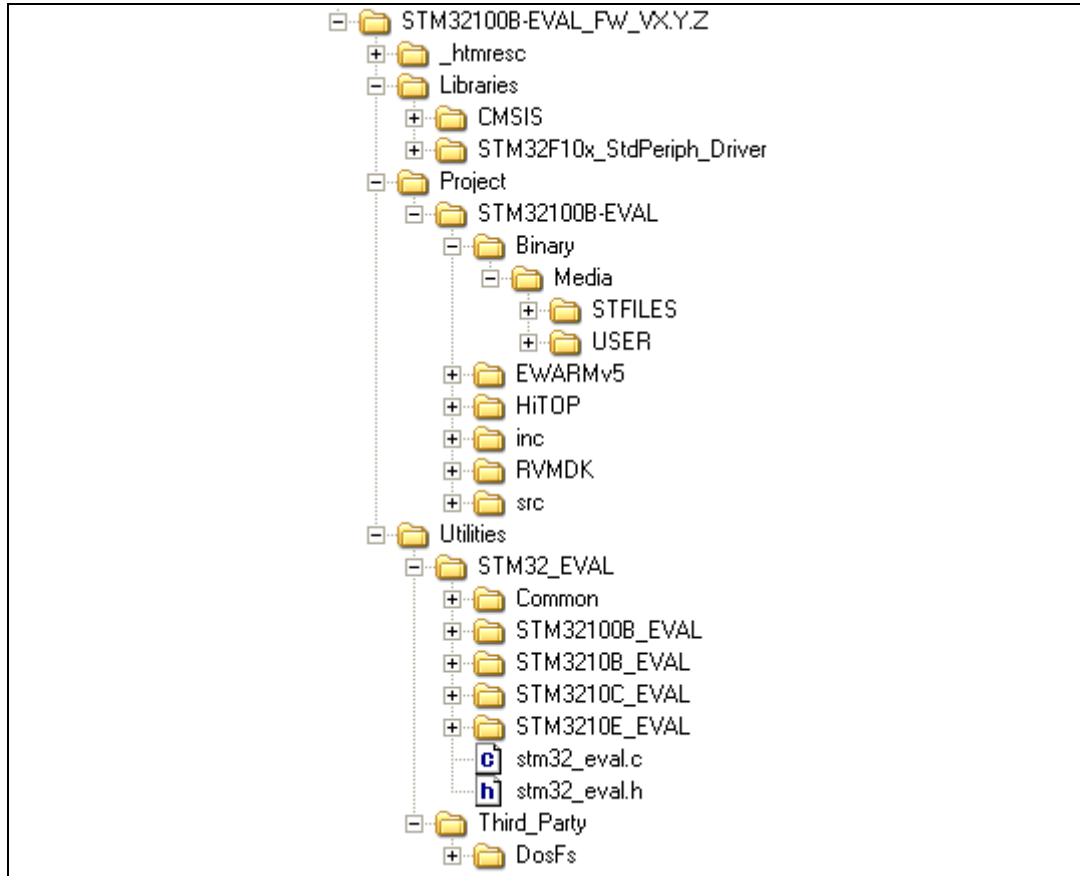

#### 3.1 Libraries

The **Libraries** folder contains all the subdirectories and files that make up the core of the STM32F10xxx Standard Peripheral library V3.2.0:

- **CMSIS**
  - **CM3\CoreSupport**: contains the Cortex-M3 files
  - **CM3\DeviceSupport\ST\STM32F10x**: contains the STM32F10x CMSIS layers files.
- **STM32F10x\_StdPeriph\_Driver**
  - **inc** subfolder: contains the Standard Peripheral library header files
  - **src** subfolder: contains the Standard Peripheral library source files

## 3.2 Project

### STM32100B-EVAL

- **Binary:** contains the binary image of the demonstration that can be used to program the binary image to the internal Flash memory using IAP, plus the needed Media files to run the demonstration (Binary\Media).
- **EWARMv5:** contains preconfigured projects for the EWARM toolchain
- **RVMDK:** contains preconfigured projects for the RVMDK toolchain
- **HiTOP:** contains preconfigured projects for the HiTOP toolchain
- **inc** subfolder: contains the demonstration header files
- **src** subfolder: contains the demonstration source files

## 3.3 Utilities

**STM32100B-EVAL:** contains the LCD, and other STM32100B-EVAL board-related drivers.

## 4 STM32100B-EVAL demonstration programming

### 4.1 Programming the media files

The STM32100B-EVAL board comes with an MicroSD card memory preprogrammed with audio and image resources used by the demonstration. However you can load your own image (\*.bmp) and audio (\*.wav) files in the “USER” directory, providing that these file formats are supported by the demonstration. For more details please refer to [Section 2.7.4: Wave Player submenu](#) and [Section 2.7.3: Images Viewer submenu](#) section.

**Figure 70. SD card directory organization**

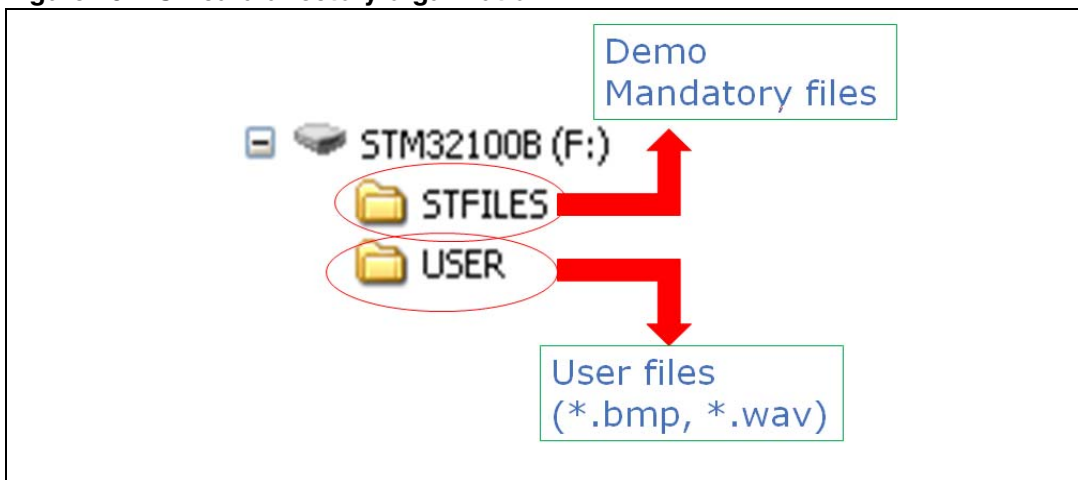

The default content of the media files (STFILES and USER directories) can be retrieved under the Binary\Media folder. So if you want to reprogram the MicroSD card, you can copy the content of the Binary\Media to your own SD memory.

### 4.2 Programming the demonstration

You can program the demonstration using 2 methods:

#### Using the Bootloader

To program the demonstration binary images into the internal Flash memory, you have to use the `stm32100b_eval_fw_v1.0.0.bin` file with embedded Bootloader. For more details, please refer to the Bootloader application note AN2606.

#### Using preconfigured projects

1. Select the folder corresponding to your preferred toolchain (RVMDK, EWARMv5 or HiTOP)
2. Open the STM32100B\_EVAL project and rebuild all sources
3. Load the project image through your debugger
4. Restart the evaluation board (Press B1: reset button)

## 5 Revision history

**Table 4. Document revision history**

| Date        | Revision | Changes          |
|-------------|----------|------------------|
| 26-Feb-2010 | 1        | Initial release. |

**Please Read Carefully:**

Information in this document is provided solely in connection with ST products. STMicroelectronics NV and its subsidiaries ("ST") reserve the right to make changes, corrections, modifications or improvements, to this document, and the products and services described herein at any time, without notice.

All ST products are sold pursuant to ST's terms and conditions of sale.

Purchasers are solely responsible for the choice, selection and use of the ST products and services described herein, and ST assumes no liability whatsoever relating to the choice, selection or use of the ST products and services described herein.

No license, express or implied, by estoppel or otherwise, to any intellectual property rights is granted under this document. If any part of this document refers to any third party products or services it shall not be deemed a license grant by ST for the use of such third party products or services, or any intellectual property contained therein or considered as a warranty covering the use in any manner whatsoever of such third party products or services or any intellectual property contained therein.

**UNLESS OTHERWISE SET FORTH IN ST'S TERMS AND CONDITIONS OF SALE ST DISCLAIMS ANY EXPRESS OR IMPLIED WARRANTY WITH RESPECT TO THE USE AND/OR SALE OF ST PRODUCTS INCLUDING WITHOUT LIMITATION IMPLIED WARRANTIES OF MERCHANTABILITY, FITNESS FOR A PARTICULAR PURPOSE (AND THEIR EQUIVALENTS UNDER THE LAWS OF ANY JURISDICTION), OR INFRINGEMENT OF ANY PATENT, COPYRIGHT OR OTHER INTELLECTUAL PROPERTY RIGHT.**

**UNLESS EXPRESSLY APPROVED IN WRITING BY AN AUTHORIZED ST REPRESENTATIVE, ST PRODUCTS ARE NOT RECOMMENDED, AUTHORIZED OR WARRANTED FOR USE IN MILITARY, AIR CRAFT, SPACE, LIFE SAVING, OR LIFE SUSTAINING APPLICATIONS, NOR IN PRODUCTS OR SYSTEMS WHERE FAILURE OR MALFUNCTION MAY RESULT IN PERSONAL INJURY, DEATH, OR SEVERE PROPERTY OR ENVIRONMENTAL DAMAGE. ST PRODUCTS WHICH ARE NOT SPECIFIED AS "AUTOMOTIVE GRADE" MAY ONLY BE USED IN AUTOMOTIVE APPLICATIONS AT USER'S OWN RISK.**

Resale of ST products with provisions different from the statements and/or technical features set forth in this document shall immediately void any warranty granted by ST for the ST product or service described herein and shall not create or extend in any manner whatsoever, any liability of ST.

ST and the ST logo are trademarks or registered trademarks of ST in various countries.

Information in this document supersedes and replaces all information previously supplied.

The ST logo is a registered trademark of STMicroelectronics. All other names are the property of their respective owners.

© 2010 STMicroelectronics - All rights reserved

STMicroelectronics group of companies

Australia - Belgium - Brazil - Canada - China - Czech Republic - Finland - France - Germany - Hong Kong - India - Israel - Italy - Japan - Malaysia - Malta - Morocco - Philippines - Singapore - Spain - Sweden - Switzerland - United Kingdom - United States of America

[www.st.com](http://www.st.com)