

Enpirion EP5368QI DC/DC Converter Module Evaluation Board

Introduction

This application note describes how to test the EP5368QI converter using the Enpirion 3x3 Module EVAL BOARD shown in Fig. 1. In addition to this document you will also need the device datasheet.

The EP5368QI converter is part of a new class of DC/DC converter products, a complete power system on silicon:

- This device is a complete module including magnetics, and requires only ceramic input and output capacitors.
- The evaluation board is designed to offer a wide range of engineering evaluation capabilities. This includes the base configuration of an 0603 input capacitor and an 0805 output capacitor.
- Pads are available to add up to one additional input capacitor and up to two additional output capacitors to allow for evaluation of performance over a wide range of input/output capacitor combinations.
- Pads are available to populate an external resistor divider if desired.
- Easy jumpers are provided for the following signals:
 - Enable
 - VS0-VS2 output voltage select
- The following signals on the eval board are not used for the EP5368QI:
 - Adaptive-biased light load mode (LLM)
 - VS3 output voltage select pin
- Numerous test points are provided as well as clip leads for input and output connections
- The board comes with input decoupling, and input reverse polarity protection to safeguard the device from common setup mishaps.

Quick Start Guide

STEP 1: Set the “ENABLE” jumper to the Disable Position.

CAUTION: the signal pins, ENA, VS0, VS1, and VS2 must be connected to a logic “high”, jumper to the left, or a logic “low”, jumper to the right. If left floating the state is indeterminate.

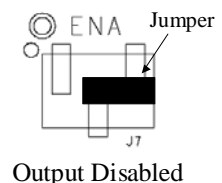

STEP 2: Connect a power supply to the input test points, TP8 (+) and TP5 (-) as indicated in Figure 1. The same test points can also be used to measure the input voltage.

CAUTION: be mindful of the polarity and the voltage magnitude. If V_{IN} is greater than the absolute maximum rating in the datasheet, the board may get damaged. If the input voltage polarity is wrong, diode D1 will conduct, and draw excessive input current.

STEP 3: Set the output voltage select pins for the desired output voltage. Refer to Table 1 to determine the setting.

CAUTION: the external resistor divider is not populated in the standard board configuration. Choosing the “EXT” option for the EP5368QI without the external resistors R1 and R2 will result in unpredictable behavior.

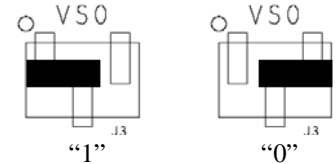

STEP 4: Connect the load to the output connectors TP7 (+) and TP6 (-), as indicated in Figure 1. The same test points are also used to measure the DC output voltage.

STEP 6: Move the ENABLE jumper to the enabled position, and power up the board. The EP5368QI should now be operational.

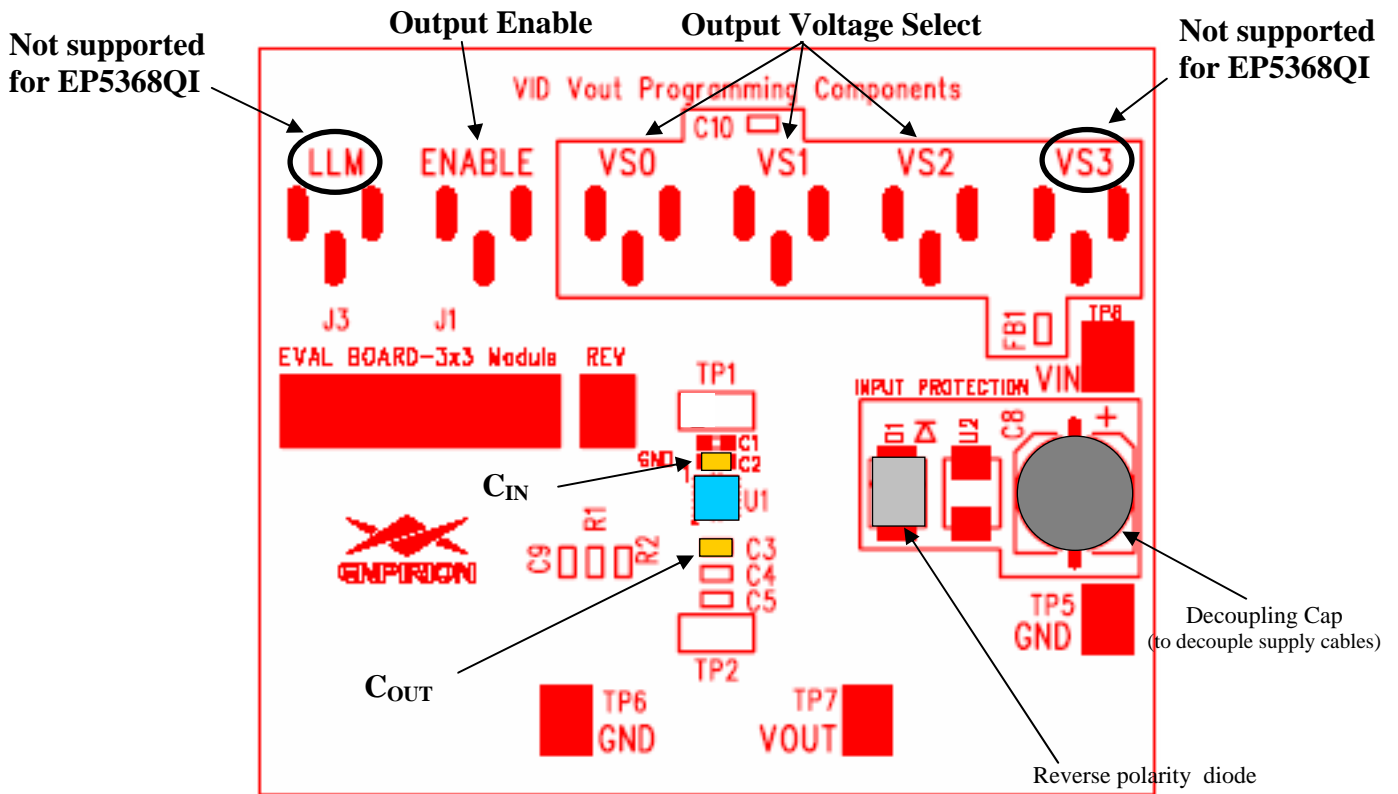

Figure 1: Evaluation Board Layout. This board is used for multiple Enpirion 3x3 products. Some of the functions are not supported in all of these products.

Output Voltage Select

Table 1. EP5368QI Output Voltage Select Truth Table

VS2	VS1	VS0	V _{OUT}
0	0	0	3.3V
0	0	1	2.5V
0	1	0	1.8V
0	1	1	1.5V
1	0	0	1.25V
1	0	1	1.2V
1	1	0	0.8V
1	1	1	EXT

The EP5368QI utilizes a 3 pin output voltage select scheme. The output voltage is programmed by setting the VSx jumpers to either a logic “1” or a logic “0” as described in the Quick Start section

Table 1 shows the truth table for V_{OUT} selection. There are seven preset output voltage levels, and one option for external resistor programming.

Test Recommendations

To guarantee measurement accuracy, the following precautions should be observed:

1. Make all input and output voltage measurements at the board using the test points provided. This will eliminate voltage drop across the line and load cables that can produce false readings.
2. Measure input and output current with series ammeters or accurate shunt resistors. This is especially important when measuring efficiency.
3. Use a balanced impedance probe tip as shown in Figure 2, and through-hole test point pair TP2 to measure the output voltage ripple to avoid noise coupling into the probe ground lead. Similarly, TP1 can be used to measure input voltage ripple.

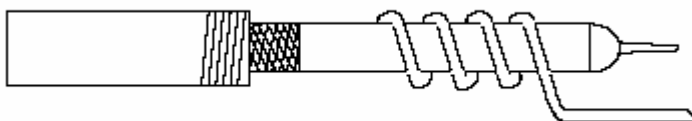

Figure 2: Balanced-impedance oscilloscope probe. Wrap bare wire around the ground shaft and bring the wire close to the probe tip. This minimizes probe loop inductance and stray noise pickup by the probe.

Using The External Voltage Divider

The EP5368QI evaluation board is designed to provide a great deal of flexibility in evaluating the performance of the Enpirion DC/DC module. The external voltage divider option is chosen by setting the jumpers VS0 – VS2 to a logic “high”.

Pre-tinned pads are provided to place 0805 sized 1% resistors on the board to implement an external resistor divider for choosing an output voltage other than one of the pre-set voltages available on the VID. See Figure 3 for the basic circuit.

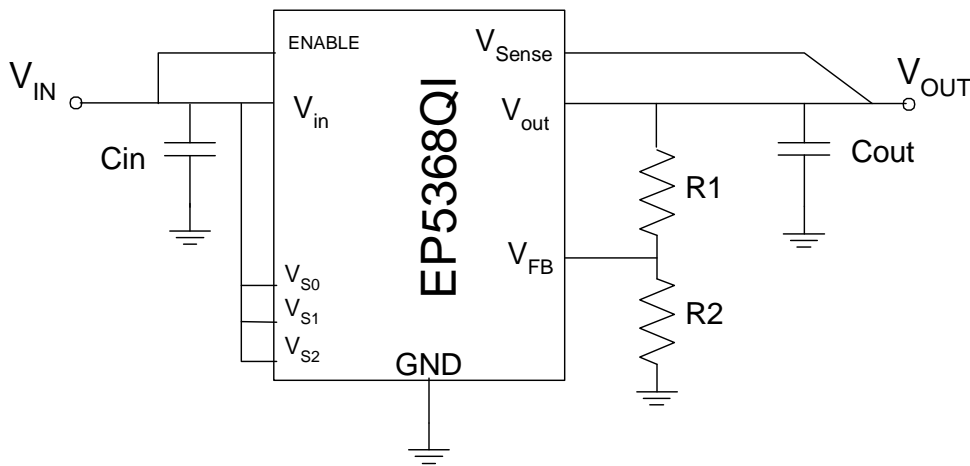

Figure 3. External divider schematic for the EP5368QI.

The output voltage is selected by the following formula:

$$V_{OUT} = 0.603V\left(1 + \frac{R1}{R2}\right)$$

R₁ must be chosen as 200kΩ to maintain control loop stability. Then R₂ is given as:

$$R_2 = \frac{0.603R1}{V_{OUT} - 0.603} \Omega$$

NOTE: Even though it is possible to run the EP5368QI up to 700mA using an external voltage divider as outlined in the datasheet, this evaluation board is only configured to run this part up to 600mA. Please contact Enpirion applications if you would like to modify this board to push the output current up to 700mA.

Dynamically Adjustable Output

The EP5368QI is designed to allow for dynamic switching between the predefined voltage levels by toggling the VID pins. The inter-voltage slew rate is optimized to prevent excess undershoot or overshoot as the output voltage levels transition. The slew rate is defined in the datasheet.

This feature can be tested by connecting the VSx jumper center pins to logic drivers to toggle between the various V_{OUT} states.

Input and Output Capacitors

The **input** capacitance is a single 0603 X5R MLCC. Please see the datasheet for the exact value. There are pre-tinned pads that allows for one additional 0603 capacitor to experiment with input filter performance.

The **output** capacitance requirement is a single 0805 X5R MLCC. Please see the datasheet for the exact value. The board has pre-tinned pads for up to 2 additional 0805 output capacitors.

NOTE: Capacitors must be X5R or X7R dielectric formulations. Do not use Y5V or any similar dielectric.

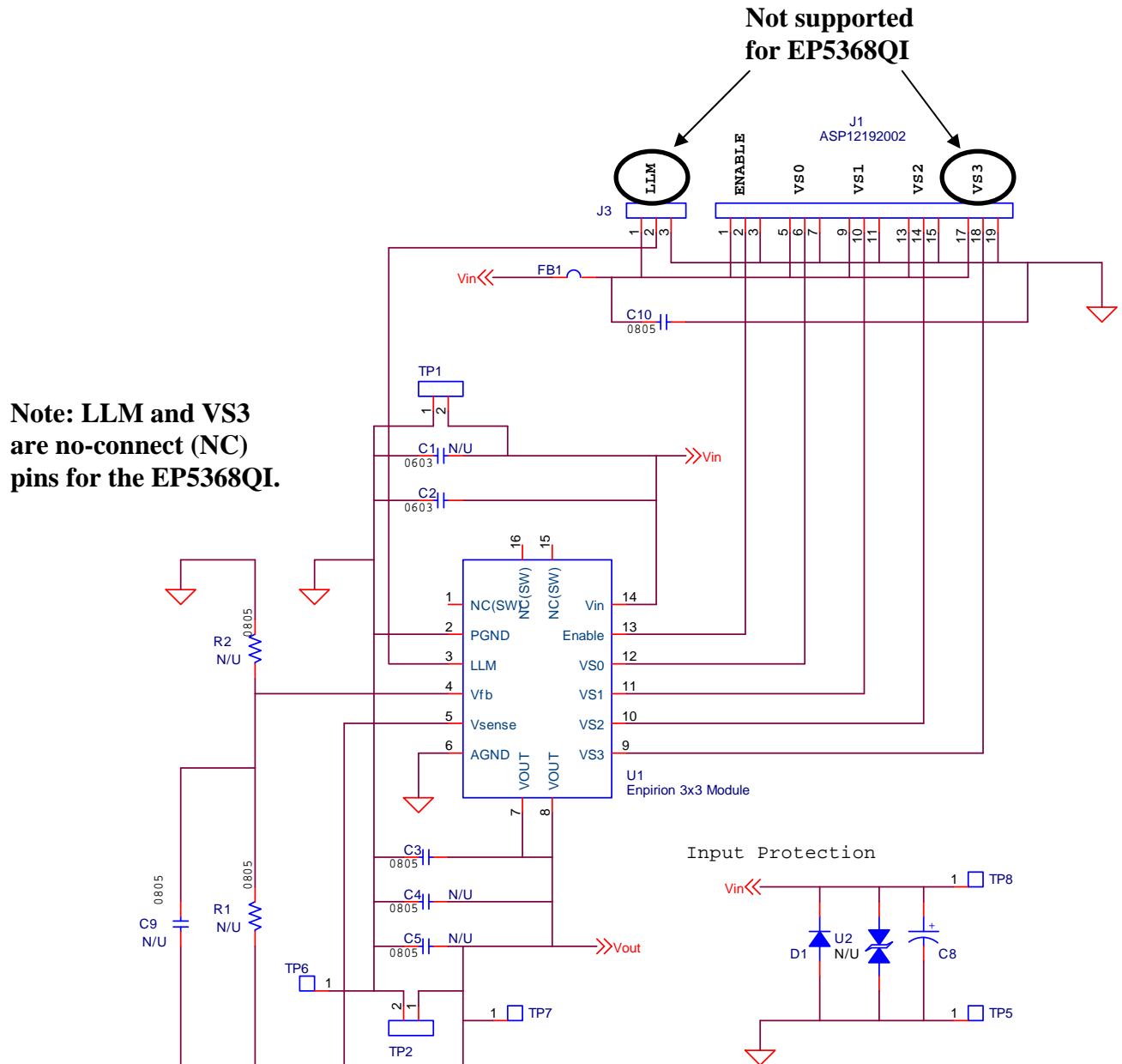

Figure 4: 3x3 Module Evaluation Board Schematic

Contact Information

Enpirion, Inc.
685 Route 202/206
Suite 305
Bridgewater, NJ 08807
Phone: 908-575-7550
Fax: 908-575-0775

Enpirion reserves the right to make changes in circuit design and/or specifications at any time without notice. Information furnished by Enpirion is believed to be accurate and reliable. Enpirion assumes no responsibility for its use or for infringement of patents or other third party rights, which may result from its use. Enpirion products are not authorized for use in nuclear control systems, as critical components in life support systems or equipment used in hazardous environment without the express written authority from Enpirion.