

PRODUCT BULLETIN

D*U SUBMINIATURE CONNECTOR WITH CRIMP STYLE REMOVABLE CONTACTS

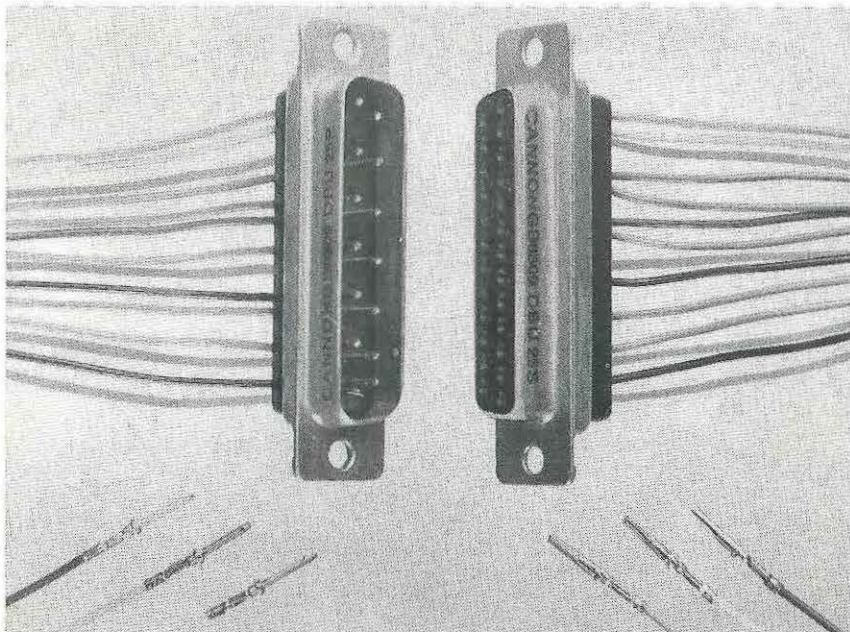

Features

- Stamped and formed contacts with insulation support
- Insulation support contacts fully recessed in insulation after assembly
- Flame retardant insulators (UL approved material)
- Fully intermateable with all Cannon D connectors
- Contacts only loaded into selected cavities
- Stamped and formed contacts supplied in reel form (7500 contacts per reel) or loose in bags of 100
- Choice of semi-automatic or manual tooling
- Option of machined contacts

The new D*U connector permits selective loading of crimp terminated pin and socket contacts providing lower installed costs

The contacts are quickly terminated using low cost hand, bench mounted or semi-automatic crimp tooling (see back page for details). Terminated contacts are inserted and extracted from the rear of the connector using an expendable plastic insertion/extraction tool.

D*U connectors operate in temperatures up to 120°C and are used in plug-in module applications, cable-to-cable and cable-to-panel installations, computer, business machines and many other commercial applications.

Standard Data

Standard materials and finishes

Shell	Steel, plated zinc with yellow chromate Tin Plated (ROHS)
Insulator	Glass-filled black thermoplastic (UL94VO Grade)
Contacts	Machined: Copper alloy, gold over nickel plate Stamped: Phosphor-bronze, gold over nickel plate

Mechanical Features

Coupling	Friction and lock accessories
Polarization	Keystone-shaped shells
Contact Type	Crimp snap-in

Electrical Data

Contact Termination	Crimp style
Wire Size (stamped)	Size 20 contacts: 22 to 28AWG stranded wire;
(machined)	Size 20 contacts: 18 to 30AWG stranded wire.
Current Rating	Size 20 contacts: 5 amps

Voltage Rating	Average Flashover	Test
Sea level	1,500 VAC	1,000 VAC
20,000 ft	1,000 VAC	650 VAC
70,000 ft	500 VAC	325 VAC
120,000 ft	255 VAC	175 VAC

ITT CANNON

Jays Close, Viabes Industrial Estate,
Basingstoke, Hants. RG22 4BW.

Tel: Basingstoke (0256) 473171 Telex: 858105

ITT CANNON

PB-DU-3 (GB)

Standard Shell

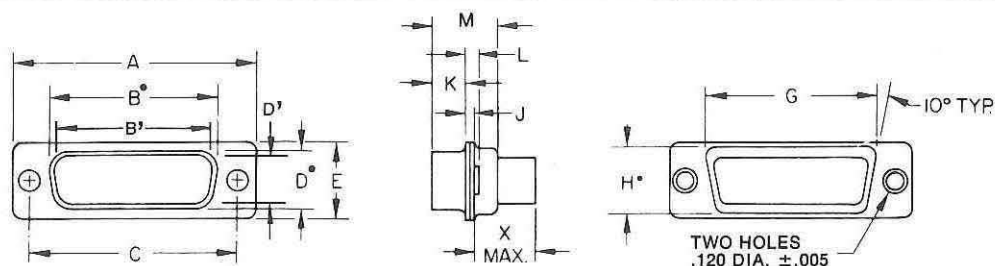

Part Number be Shell Size	A ±0.4	B [●] ±0.3	B' ±0.3	C ±0.2	D [●] ±0.3	D' ±0.3	E ±0.4	G ±0.3	H ±0.3	J ±0.3	K ±0.3	L Max.	M ±0.3	N ±0.3	X Max.
DEU-9P-FO *	30.8		16.9	25.0		8.4	12.5	19.3	10.7	0.8	6.0	1.90	10.7	3.0	9.5
DEU-9S-FO *	30.8	16.3		25.0	7.8		12.5	19.3	10.7	0.8	6.2	1.90	10.9	3.0	9.5
DAU-15P-FO *	39.1		25.3	33.3		8.4	12.5	27.5	10.7	0.8	6.0	1.90	10.7	3.0	9.5
DAU-15S-FO *	39.1	24.6		33.3	7.8		12.5	27.5	10.7	0.8	6.2	1.90	10.9	3.0	9.5
DBU-25P-FO *	53.0		39.0	47.0		8.4	12.5	41.3	10.7	1.0	5.9	1.90	10.8	3.3	9.5
DBU-25S-FO *	53.0	38.3		47.0	7.8		12.5	41.3	10.7	0.8	6.2	1.90	10.9	3.0	9.5
DCU-37P-FO *	69.3		55.4	63.5		8.4	12.5	57.7	10.7	1.0	5.9	1.90	10.8	3.3	9.5
DCU-37S-FO *	69.3	54.8		63.5	7.8		12.5	57.7	10.7	0.8	6.2	1.90	10.9	3.0	9.5
DDU-50P-FO *	66.9		52.8	61.1		11.1	15.4	55.3	13.6	1.0	5.9	1.90	10.8	3.3	9.5
DDU-50S-FO *	66.9	52.4		61.1	10.7		15.4	55.3	13.6	0.8	6.2	1.90	10.9	3.0	9.5

NOTE: Dimensions B[●], D[●], G[●] and H[●] are measured as outside dimensions at the bottom of the draw. B[●] and D[●] are the O.D. dims. for socket side; B' and D' are the dims. for pin side.

Part Number suffix FO indicate connectors supplied without contacts.

- * ROHS compliant version add the following modification codes : pin version add **K87** (tin plated shell with grounding dimples) socket version add **A197** (tin plated shell)
- example part number, 9 way pin = DEU-9P-K87-FO

Stamped Contacts

Insulation Support

Stamped contacts are furnished on reels for use with the semi-automatic crimp and strip/crimp machines. These contacts will accommodate wire sizes 22 to 28AWG stranded wire. For solid wire accommodation please consult the factory. Contacts are also available loose in bags of 100.

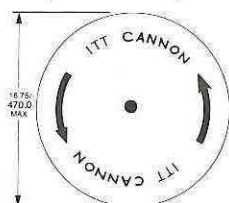

Contact (Reeled 7500 per reel)	20-22	20-26
Pin	077069-0200	077069-0202
Socket	077069-0201	077069-0203
Contact (loose in bags of 100)		
Pin	330-7633-010	330-7635-010
Socket	330-7634-010	330-7636-010

PIN

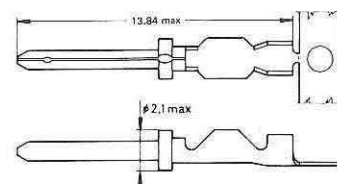

SOCKET

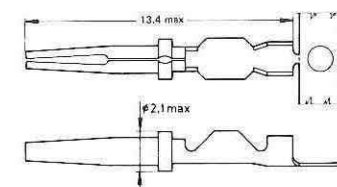

Machined Contacts

Machined contacts are furnished loose.

Contact	Contact Part Number	A ±0,05	B ±0,05	C Max.
Pin 20-20	030-1952-000	1,7	1,1	13,6
Pin 20-18	030-1954-000	2,1	1,7	22,2
Pin 20-26	030-1952-002	1,7	0,6	13,6
Socket 20-20	030-1953-000	1,7	1,1	13,3
Socket 20-18	030-1955-000	2,1	1,6	21,6
Socket 20-26	030-1953-002	1,7	0,6	13,3

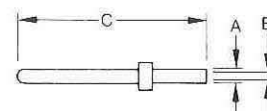
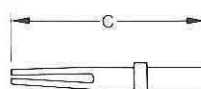

NOTE: for 20-18 contacts only:
Shrink sleeving is suggested on the crimp pot to prevent contacts from touching.

Panel Cutouts

Standard Cutout

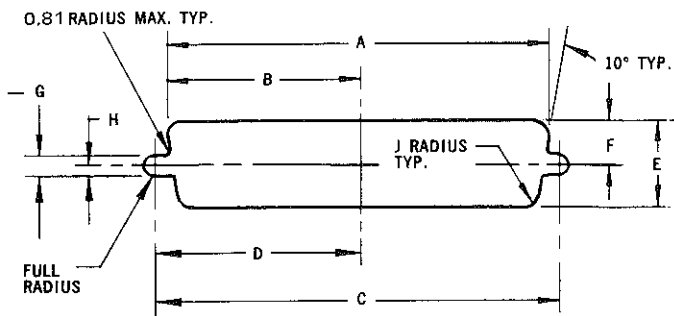

Optional Cutout (For rear mounting)

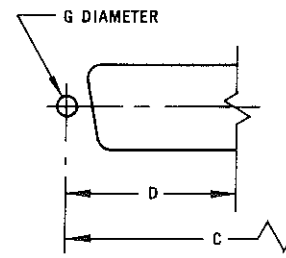

Connector Size	Mounting Method	A ±0.2	B ±0.2	C ±0.2	D ±0.2	E ±0.2	F ±0.2	G ±0.1	H ±0.1	K ±0.2
DAU	Front Mounting	30.5	15.3	33.3	16.7	13.0	6.5	3.0	1.5	2.1
	Rear Mounting	28.8	14.4	33.3	16.7	11.4	5.7	3.0	1.5	3.4
DBU	Front Mounting	44.3	22.1	47.0	23.5	13.0	6.5	3.0	1.5	2.1
	Rear Mounting	42.5	21.3	47.0	23.5	11.4	5.7	3.0	1.5	3.4
DCU	Front Mounting	60.7	30.4	63.5	31.7	13.0	6.5	3.0	1.5	2.1
	Rear Mounting	59.1	29.5	63.5	31.7	11.4	5.7	3.0	1.5	3.4
DDU	Front Mounting	58.3	29.2	61.1	30.6	15.8	7.9	3.0	1.5	2.1
	Rear Mounting	56.3	28.2	61.1	30.6	14.1	7.1	3.0	1.5	3.4
DEU	Front Mounting	22.2	11.1	25.0	12.5	13.0	6.5	3.0	1.5	2.1
	Rear Mounting	20.5	10.2	25.0	12.5	11.4	5.7	3.0	1.5	3.4

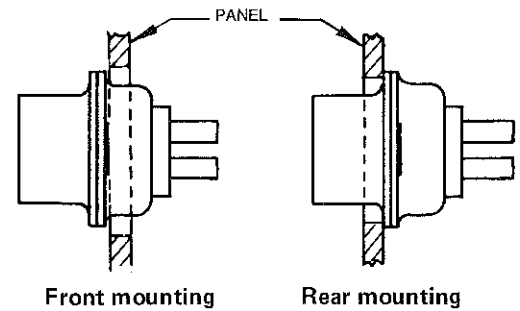

Panel Mounting

NOTE: A, B, C, and H are dimensions between panels and represent the recommended limit to be used in the design of the connector mounting method.

PIN FRONT MOUNTING PIN REAR MOUNTING

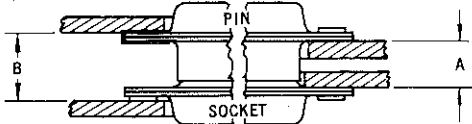

SOCKET FRONT MOUNTING SOCKET REAR MOUNTING

PIN REAR MOUNTING PIN FRONT MOUNTING

4.75 MAX. ROLL OVER TYPICAL

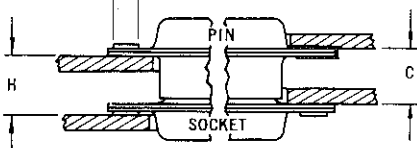

SOCKET FRONT MOUNTING SOCKET REAR MOUNTING

Combination of mated connectors

Size	A +0.76 -0	B +0.76 -0	C +0.76 -0	H +0.76 -0
A, E	6.35	8.63	7.49	7.49
B, C, D	6.04	8.71	7.56	7.18

Standard pin assemblies contain 0.38 thick front shells on E and A sizes; 0.61 thick front shells on B, C and D sizes.

Rear Release Contact Retention System

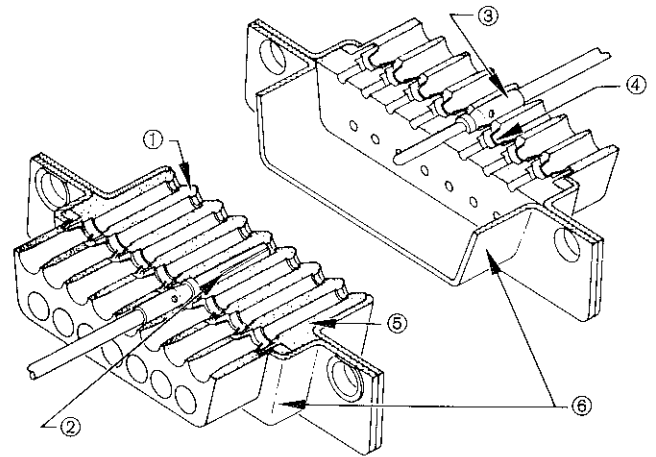

- ① Closed-entry socket insulator
- ② Sleeveless spring finger contact
- ③ Contacts crimped with standard tools
- ④ Contact retaining tines
- ⑤ Flame retardant insulator
- ⑥ Standard D shells

Semi-automatic Strip/Crimp Machine ACT2500

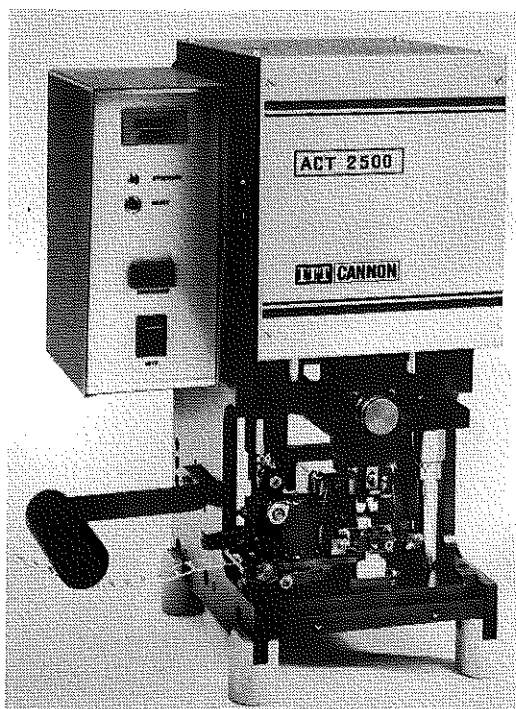

The ACT2500 quickly and reliably crimp terminates up to 1200 contacts per hour. The machine which only requires an electrical supply, is suitable for a wide variety of contacts and cable sizes. Crimp tools are easily changed. Time consuming adjustments are unnecessary, stripping and crimping is sensor released. This semi-automatic crimp machine is a practical and cost saving tool when using Cannon reeled contacts. Please ask for details of our leasing arrangements.

Hand operated Crimp Machine with automatic feed CBT9000

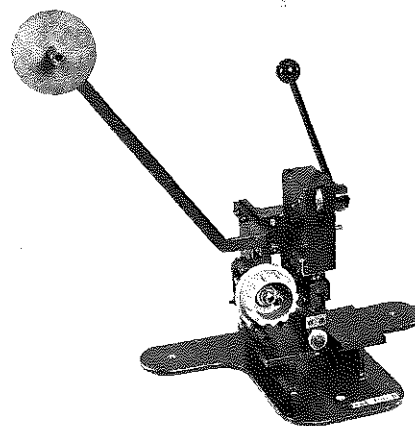

This low-cost bench-mounted hand-operated crimp machine terminates pre-stripped wire to stamped and formed reeled contacts. Its features include automatic contact feed and it is ideal for small volume requirements. Consult factory for specific ordering information. **274-7529-000**

Hand Crimp Tool CCT-D*U-5GB

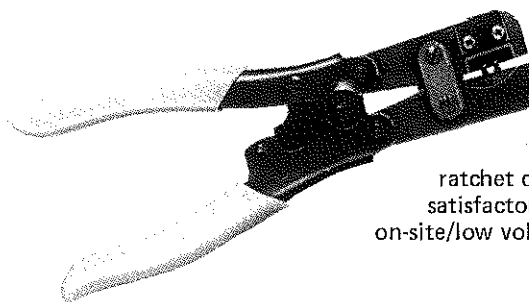

With this tool each crimp cycle is ratchet controlled to ensure a satisfactory crimp; suitable for on-site/low volume applications.

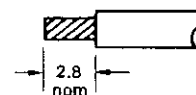

Wire Stripping Detail

Contacts and Tools

Contact Data			Tools					
Size	Suitable for conductor AWG (mm)	Contact order no.	Hand Crimp tool	Locator	Semi-Automatic Tool	Bench Mould Mounted	Insertion/ Extraction Tool	Color Insertion Extraction
Stamped, with insulation support								
20-22	22-24 (0.4-0.23)	Pin: 077069-0200 7500 contacts on reel Socket: 077069-0201	CCT-D*U-5GB	—	ACT2500	CBT9000	CIET-20HD	coloured/ white
20-26	26-28 (0.13-0.09)	Pin: 077069-0202 7500 contacts on reel Socket: 077069-0203	CCT-D*U-5GB	—	ACT2500	CBT9000	CIET-20HD	coloured/ white
20-22	22-24 (0.4-0.23)	Pin: 330-7633-010 loose in bags of 100 Socket: 330-7634-010	CCT-D*U-5GB	—			CIET-20HD	coloured/ white
20-26	26-28 (0.13-0.09)	Pin: 330-7635-010 loose in bags of 100 Socket: 330-7636-010	CCT-D*U-5GB	—			CIET-20HD	coloured/ white
machined								
20-20	20-24 (0.6-0.23)	Pin: 030-1952-000 Socket: 030-1953-000	M22520/1-01	TH 185	—		CIET-20HD	coloured/ white
20-18	18 (1.0) or (2x) 22 (0.4)	Pin: 030-1954-000 Socket: 030-1955-000	M22520/1-01	TH 185	—		CIET-2018HD	coloured/ white
20-26	26-30 (0.13-0.06)	Pin: 030-1952-002 Socket: 030-1953-002	M22520/2-01	L3198-20 HDL			CIET-20HD	coloured/ white

In line with a policy of continual product development, ITT Cannon reserve the right to change the specification of the components in this bulletin at any time and without prior notice.

META L EXTRACTION TOOL = CET-20D

945-0001-695

(WD 012-03)