

# LMZ22008,LMZ22010,LMZ23608,LMZ23610

*Application Note 2093 LMZ23610/8/6 and LMZ22010/8/6 Current Sharing  
Evaluation Board*



Literature Number: SNVA460A

# LMZ23610/8/6 and LMZ22010/8/6 Current Sharing Evaluation Board

National Semiconductor  
Application Note 2093  
Marc Davis-Marsh  
June 7, 2011



## Introduction

The LMZ23610/8/6 and LMZ22010/8/6 SIMPLE SWITCHER® power modules are easy-to-use DC-DC solution capable of driving up to a 10, 8 or 6 ampere load. They are available in an innovative package that enhances thermal performance and allows for hand or machine soldering. The LMZ23610/8/6 can accept an input voltage rail between 6V and 36V and the LMZ22010/8/6 can accept an input voltage rail between 6V and 20V.

The current sharing evaluation board is designed so that four modules can be easily connected to supply up to a 40 amp load. More can be connected as long as care is taken to not exceed the current capabilities of the banana plug connectors and the 5-amp per pin rating of the edge board connector.

The current sharing evaluation board is highly configurable. The output voltage can be changed to 5V, 3.3V, 2.5V or 1.2V with a jumper change. The external soft-start capacitor facilitates a controlled and adjustable startup rise time of the output. The board temperature can be measured with the on-board resistor. The UVLO can be adjusted by adding one resistor. To simplify the synchronization of the modules an onboard 555 timer provides an adjustable frequency clock from 350 to 600 kHz.

The LMZ23610 and LMZ22010 family is a reliable and robust solution with the following features: loss-less cycle-by-cycle valley current limit to protect for over current or short-circuit fault, thermal shutdown, input under-voltage lockout, and will start up into a pre-biased output.

## Board Specifications

- $V_{IN} = 6V$  to 36V (LMZ23610/8/6)
- $V_{IN} = 6V$  to 20V (LMZ22010/8/6)
- $V_{OUT} = 1.2V, 2.5V, 3.3V$  or 5V (minimum input voltage of 7V required for 5V output)
- $I_{OUT} = 0$  to 10, 8, or 6 Amps
- $\theta_{JA} = 8.8\text{ }^{\circ}\text{C} / \text{W}$ ,  $\theta_{JC} = 1.0\text{ }^{\circ}\text{C} / \text{W}$
- Designed on four layers; Inner are 2 oz copper; Outer are 2 oz copper.
- Measures 3.54" x 3.54" (90 mm x 90 mm) and is 62 mils (1.57 mm) thick of FR4 laminate material

For additional circuit considerations, including additional output voltage options, refer to the Applications Section section of the LMZ23610/8/6 or LMZ22010/8/6 data sheets. For negative output voltage connections see AN-2027.

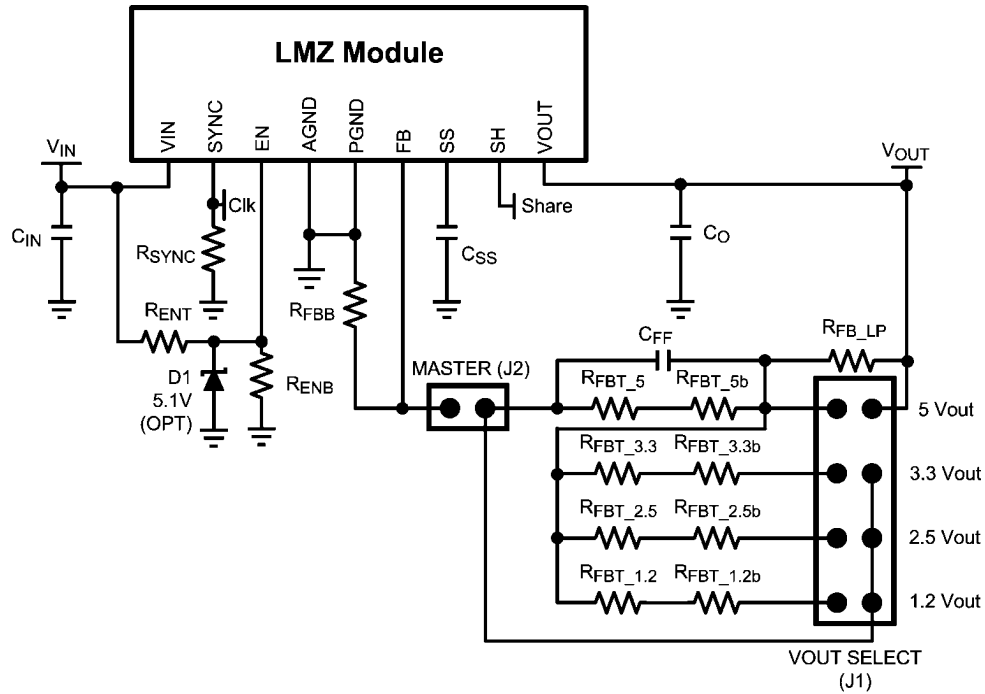

FIGURE 1. Simplified Schematic

## Test Connections

The board should be connected to a power supply and load as shown below in [Figure 2](#). The EN post is connected to the UVLO circuit on the back of the board. There is a resistive divider implemented on the board, with the bottom resistor unpopulated, that can be used to establish a precision UVLO level of the board. A common user change to this circuit is to adjust the value of RENT and RENB to adjust the operating UVLO to that of the target application. Refer to the respective data sheet for calculation. Note that if in the end application the EN pin voltage does not exceed 5.5V at maximum  $V_{in}$ ,

then the enable clamp zener D1 can be omitted. Pull EN low to shutdown the module and clock circuitry.

The SYNC post is connected to the output of a 555 timer on the back of the board and is fed to the SYNC pin of the device. This clock is provided to simplify the testing of the current sharing features of the device and is not required for stand alone operation. The frequency of the clock can be adjusted from 350kHz to 600kHz using the potentiometer labeled R\_freq\_adj. Jumper J3 (SLAVE) can be used to disable the 555 timer and allow the use of external clocks from 314 to 600 kHz.

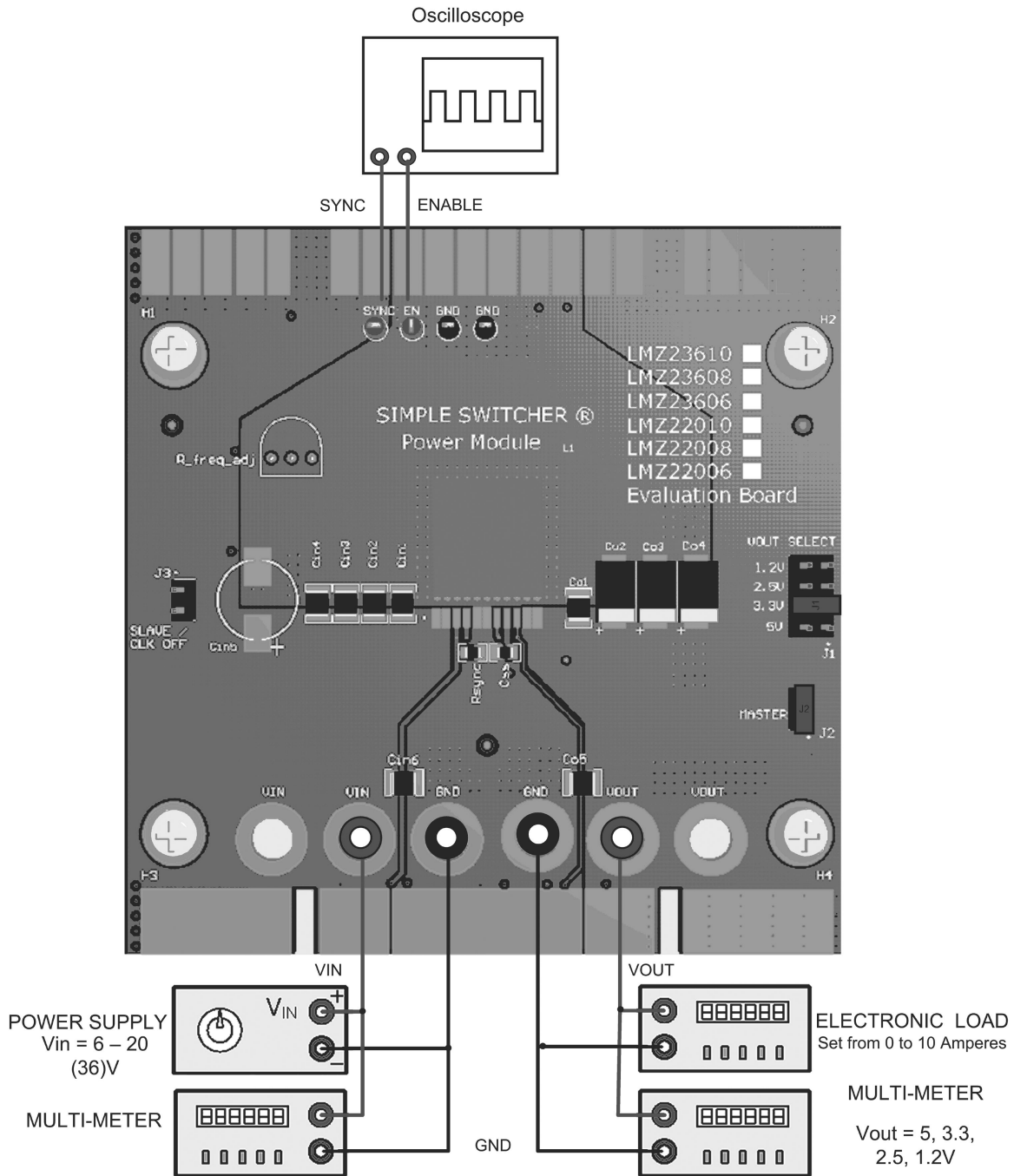

30138701

FIGURE 2. Board Connection Diagram

## Edge Connector

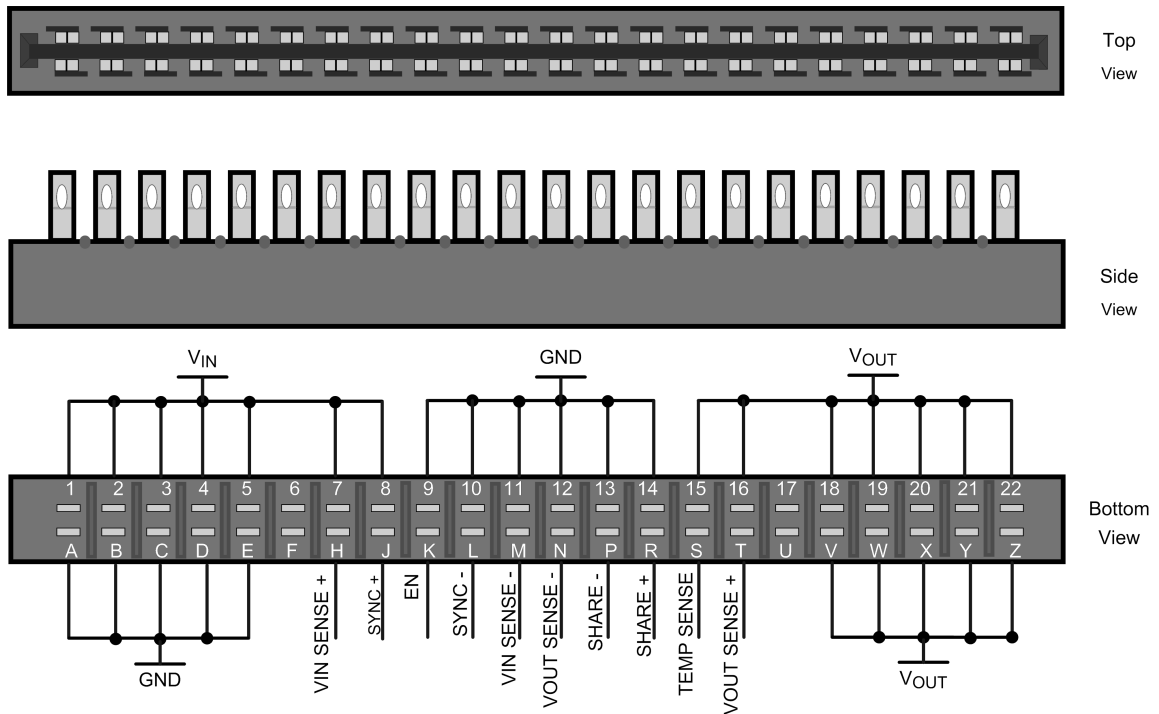

30138706

**FIGURE 3. Edge Connector Diagram**

The evaluation board is also compatible with the 44-pin edge connector shown in [Figure 3](#). The table below explains the functionality of the pins.

Pin	Name	Description
1, 2, 3, 4, 5, 7, 8	VIN	Input supply — Nominal operating range is from 6V to 20V for the LMZLMZ22010/8/6 and from 6V to 36V for the LMZLMZ23610/8/6.
9, 10, 11, 12, 13, 14, A, B, C, D, E	GND	Power Ground — Electrical path for the power circuits within the module.
15, 16, 18, 19, 20, 21, 22, V, W, X, Y, Z	VOUT	Output Voltage — Regulated 5, 3.3, 2.5 or 1.2V.
H	VIN SENSE +	Positive Kelvin Sense of Input voltage — Tied to VIN pin of the LMZ module.
M	VIN SENSE -	Negative Kelvin Sense of Input voltage — Tied to PGND (EP) of the LMZ module.
T	VOUT SENSE +	Positive Kelvin Sense of Output voltage — Tied to Vout banana jack.
N	VOUT SENSE -	Negative Kelvin Sense of Output voltage — Tied to AGND of the LMZ module.
J	SYNC +	Synchronization Positive Input — This is the positive probe point for viewing the clock generated by the 555 timer and is connected to the SYNC pin of the LMZ module. If the 555 timer is shutdown using J3 then an external clock can be used. The external clock must provide a CMOS logic level square wave whose frequency is between 314 kHz and 600 kHz.
L	SYNC -	Synchronization Negative Input — Tied to AGND of the LMZ module.
R	SHARE +	Share Positive Input — Connect this pin to the share pin of other LMZ modules to share the load between the devices.
P	SHARE -	Share Negative Input — Tied to AGND of the LMZ module.

Pin	Name	Description
K	EN	Enable — Input to the precision enable comparator of the LMZ Module. Also tied to a pull-up resistor to enable the 5v bias supply and the 555 timer.
S	TEMP SENSE	Connected to top of the R <sub>ts</sub> temperature sensing resistor. Temperature measurements can be made by measuring the temperature dependant resistance between TEMP SENSE and VIN SENSE -. Convert the resistance to temperature with the following equation: Temperature (C) $\approx$ 2.6245 x Resistance ( $\Omega$ ) - 262.7

## Adjusting the Output Voltage

The output voltage of the evaluation board is adjusted to either 5V, 3.3V, 2.5V, or 1.2V by moving jumper J1. For other voltage options see the datasheet for adjusting the feedback resistors.

## Current Sharing

Current sharing is easy to evaluate. The next steps should be implemented only while the power to the device is off.

Select which board will be the master. This is usually the board closer to the load. Connect the master board as described above in Test Connections. Insert the slave board into the socket on the master. If there is no socket, connect a 44-pin board-edge extender to the top of the master board and solder the pins. The board-edge connector will connect Vin, Gnd, Vout, Enable, Sync and the Share pin between the boards to split the current demand between multiple boards.

On the slave board(s) remove the jumper J1 (MASTER) and move it to jumper J2 (SLAVE). This disconnects the FB pin of the slave converter(s) (J1) and disables the clock that is pro-

vided on the slave board (J2). The slave module's switching frequency will now be controlled by the clock on the master board. Turning the R\_freq\_adj pot counter clockwise lowers the clock frequency and turning the pot clockwise increases the frequency. By placing an additional jumper on J3 (SLAVE) of the master board, the 555 timer is disabled on both boards. With the clock disabled you can observe the parts performance when the devices are not synchronized, or you can supply an external clock through the SYNC post. J3 must be in place (555 disabled) on all boards to use an external clock on sync. The Sync pin of the slave can also be disconnected from the master board by removing the RSHORT resistor. This allows the user to provide a multiphase clock of their choosing to the boards.

The advantage to running the clocks out of phase is to reduce the current stress on the input and output capacitors. For two modules the clocks should be run 180 degrees out of phase, for three modules the clocks should be run 120 degrees out of phase and so on. Although local input bypass capacitors are still required, the bulk capacitance required for a given ripple voltage can be greatly reduced.

Output Voltage Ripple with Two Boards Synchronized to 350Khz

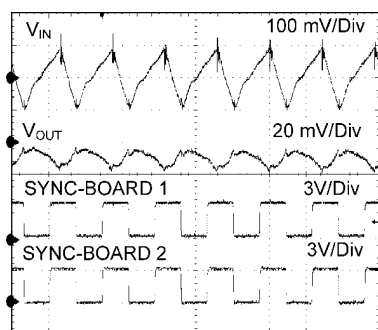

30138709

Output Voltage Ripple with Two Boards Synchronized with 180° Phase Shift

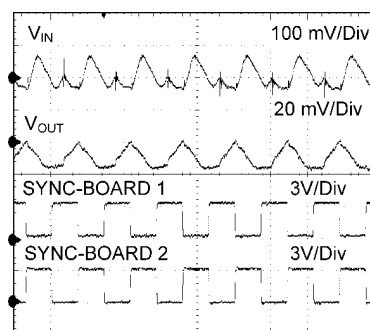

30138710

FIGURE 4. Output Voltage Ripple with Two Boards Synchronized

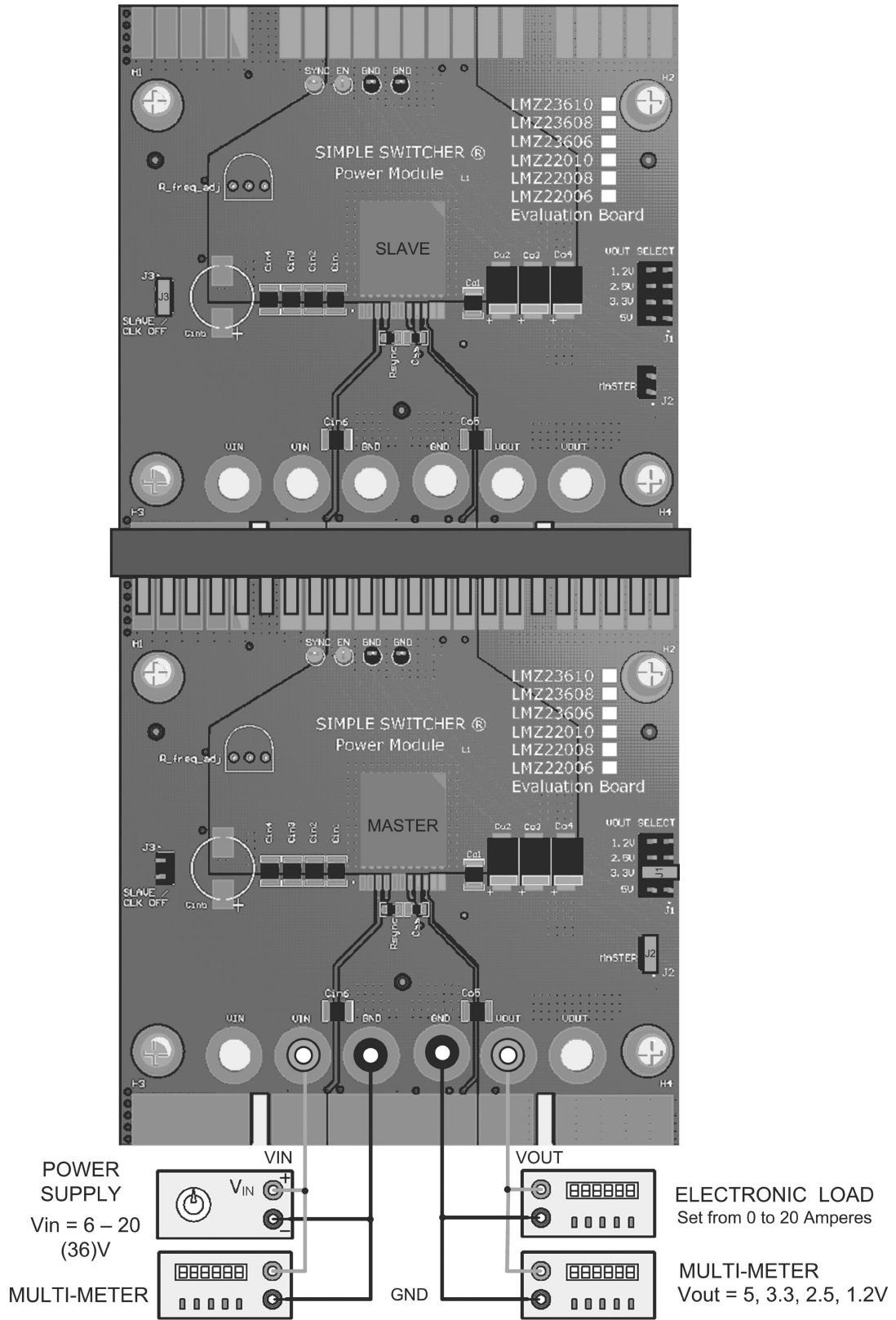

30138702

FIGURE 5. Master Slave Connection

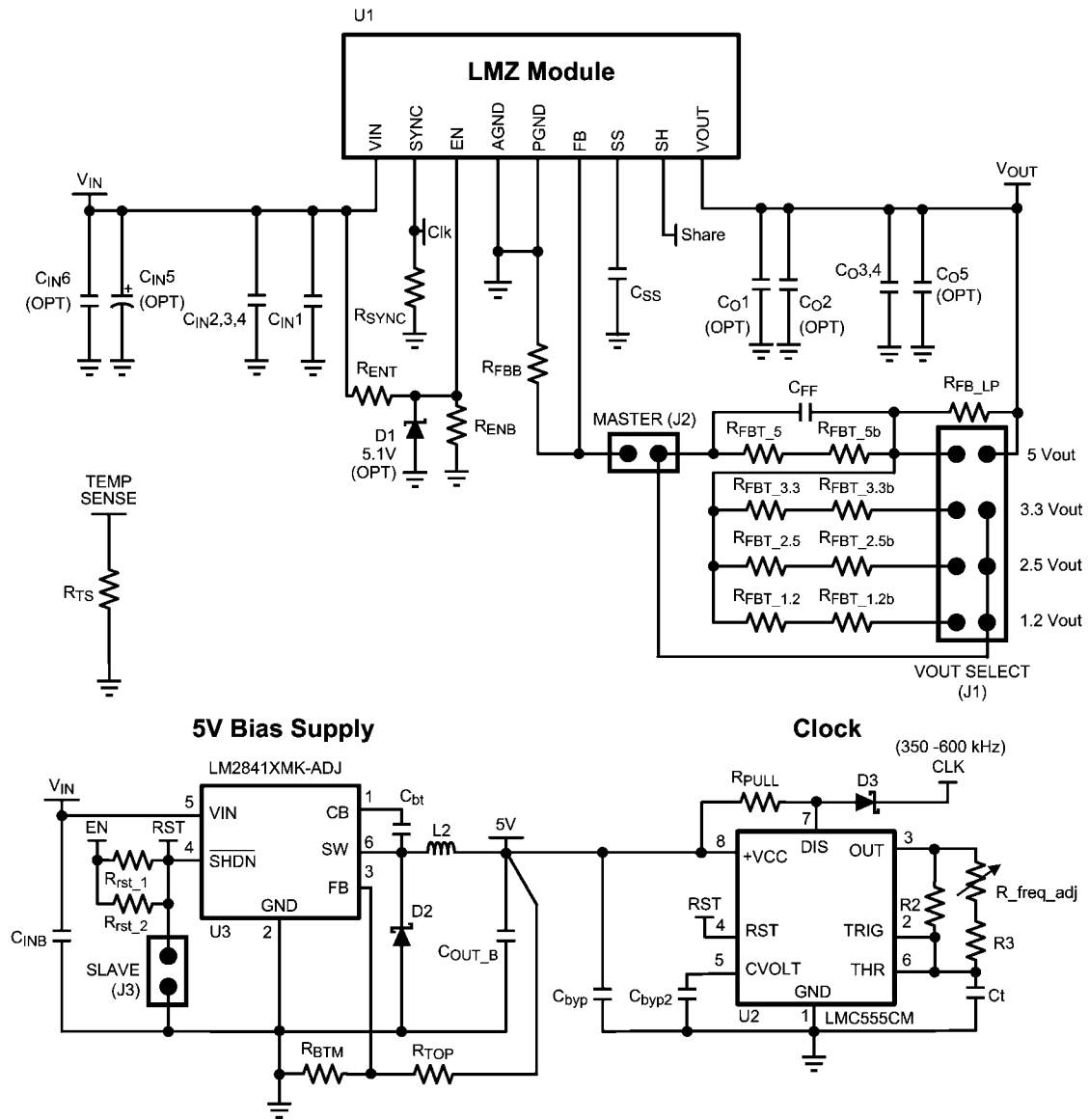

FIGURE 6. Evaluation Board Schematic

30138707



## Bill of Materials

**TABLE 1. Current Sharing Evaluation Board Bill of Materials,  $V_{IN} = 6V$  to  $36V$  (20V),  $V_{OUT} = 1.2 / 3.3V / 5V$ ,  $I_{OUT (MAX)} = 10/08/06A$**

Designator	Description	Case Size	Manufacturer	Manufacturer P/N	Quantity
U1	SIMPLE SWITCHER®	TO-PMOD-11	National Semiconductor	LMZ23610/08/06 or LMZ22010/08/06	1
U2	Timer, 8-pin Narrow SOIC, Pb-Free	TSSOP-8	National Semiconductor	LMC555CM/NOPB	1
U3	300 mA/600 mA up to 42V Input Step-Down DC/DC Regulator	SOT23	National Semiconductor	LM2841XMK-ADJL/NOPB	1
Cin1 Cin6 Co1 Co5	0.047uF, X7R, 50V	0805	Kemet	C0805C473K5RACTU	4
Cin_b Cin2 Cin3 Cin4	10 $\mu$ F, X7S, 50V	1210	TDK	C3225X7S1H106M	4
Cin5	150 $\mu$ F, Aluminum Electrolytic, 50V	G	Panasonic	EEE-FK1H151P	1
Co2 Cout_b	47uF, X5R, 10V	1210	Murata	GRM32ER61A476KE20L	2
Co3 Co4	330 $\mu$ F, 6.3V, 0.015 ohm,	2917	Kemet	T520D337M006ATE015	2
Cff	4700 pF, X7R, 50V	0805	Kemet	C0805C472K5RACTU	1
Css Cbt	0.15uF, X7R, 10V	0603	Murata	GRM188R71A154KA01D	2
Cbyp, Cbyp2	0.1uF, X7R, 50V	0805	TDK	C2012X7R1H104K	2
Ct	470pF, C0G/NP0, 50V	0805	AVX	08055A471FAT2A	1
D1	4.7V, 500mW	SOD-123	Vishay	MMSZ4688-V-GS08	1
D2	Diode, Schottky, 40V, 1A	SMA	Diodes Inc.	B140-13-F	1
D3	Diode, Schottky, 20V, 1A	SOD_123FL	ON Semiconductor	MBR120LSFT1G	1
Rent Rrst2 Rsync	1.0k ohm, 5%, 0.125W	0805	Vishay-Dale	CRCW08051K00JNEA	1
Renb	Not Populated	0805			0
Rtop	5.62k ohm, 1%, 0.125W	0805	Vishay-Dale	CRCW08055K62FKEA	1
Rbtm	1.02k ohm, 1%, 0.125W,	0805	Vishay-Dale	CRCW08051K02FKEA	1
Rfbb	1.07k ohm, 1%, 0.125W	0805	Vishay-Dale	CRCW08051K07FKEA	1
Rfbt_1.2	576 ohm, 1%, 0.125W	0805	Vishay-Dale	CRCW0805576RFKEA	1
Rfbt_1.2b	9.53 ohm, 1%, 0.125W	0805	Vishay-Dale	CRCW08059R53FKEA	1
Rfbt_2.5	3.74k ohm, 1%, 0.125W	0805	Vishay-Dale	CRCW08053K74FKEA	1
Rfbt_2.5b	84.5 ohm, 1%, 0.125W	0805	Vishay-Dale	CRCW080584R5FKEA	1
Rfbt_3.3	8.06k ohm, 1%, 0.125W	0805	Vishay-Dale	CRCW08058K06FKEA	1
Rfbt_3.3b	169 ohm, 1%, 0.125W	0805	Vishay-Dale	CRCW0805169RFKEA	1
Rfbt_5	5.6k ohm, 1%, 0.125W	0805	Vishay-Dale	CRCW08055K60FKEA	1
Rfbt_5b	73.2 ohm, 1%, 0.125W	0805	Vishay-Dale	CRCW080573R2FKEA	1
RFB_LP	20 $\Omega$	0805	Vishay-Dale	CRCW080520R0FKEA	1
Rpull	200 ohm, 1%, 0.125W	0805	Vishay-Dale	CRCW0805200RFKEA	1
Rshrt	0 ohm, 5%, 0.125W	0805	Vishay-Dale	CRCW08050000Z0EA	1

Designator	Description	Case Size	Manufacturer	Manufacturer P/N	Quantity
Rts	100 ohm, Temp Sense Resistor	0805	Vishay	PTS08051B100RP 100	1
R_freq_adj	ADJ, 100K ohm, 0.5W	Round - 0.350" Dia x 0.150" H	Bourn	3352T-1-104LF	1
R2 R3	3.48k ohm, 1%, 0.125W	0805	Vishay-Dale	CRCW08053K48FKEA	2
L2	Inductor, Shielded Drum Core, Ferrite, 22uH, 0.7A, 0.155 ohm	SMD	Würth Elektronik	744043220	1
SYNC EN	Test Point, TH, Miniature, Red		Keystone Electronics	5000	2
GND GND	Test Point, TH, Miniature, Black		Keystone Electronics	5001	2
GND GND VIN VOUT	Banana Jack Connector		Keystone Electronics	575-8	6
J1	Header, 4x2, Gold plated, 230 mil above insulator	TH, 100mil	Samtec Inc.	TSW-104-07-G-D	1
J2 J3	Header, 2x1, Gold plated, 230 mil above insulator	TH, 100mil	Samtec Inc.	TSW-102-07-G-S	2
SH-1 SH-2 SH-3	Shunt, 100mil, Gold plated, Black		Amp	382811-6	3
H1 H2 H3 H4	Machine Screw, Round, #4-40 x 1/4, Nylon, Philips panhead		B and F Fastener Supply	NY PMS 440 0025 PH	4
H5 H6 H7 H8	Standoff, Hex, 0.5"L #4-40 Nylon		Keystone	1902C	4
J4	44-Pin Edge Connector		EDAC	305-044-555-201	1
Rrst1	Not Populated				0

# Performance Characteristics

Efficiency,  $V_{OUT} = 5.0V$

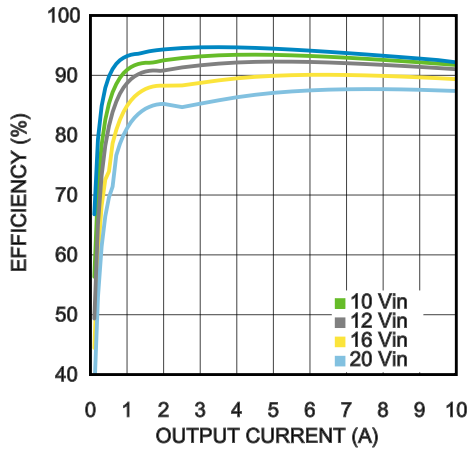

30138720

Thermal Derating,  $V_{OUT} = 5.0V$

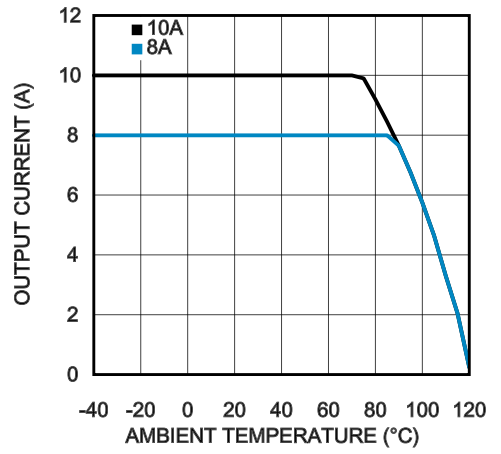

30138721

Startup,  $V_{IN} = 12V$ ,  $V_{OUT} = 3.3V$

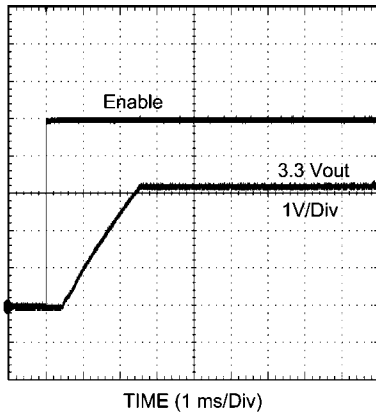

30138722

## PCB Layout Diagrams

Gerber and CAD files can be downloaded from the associated product folder.

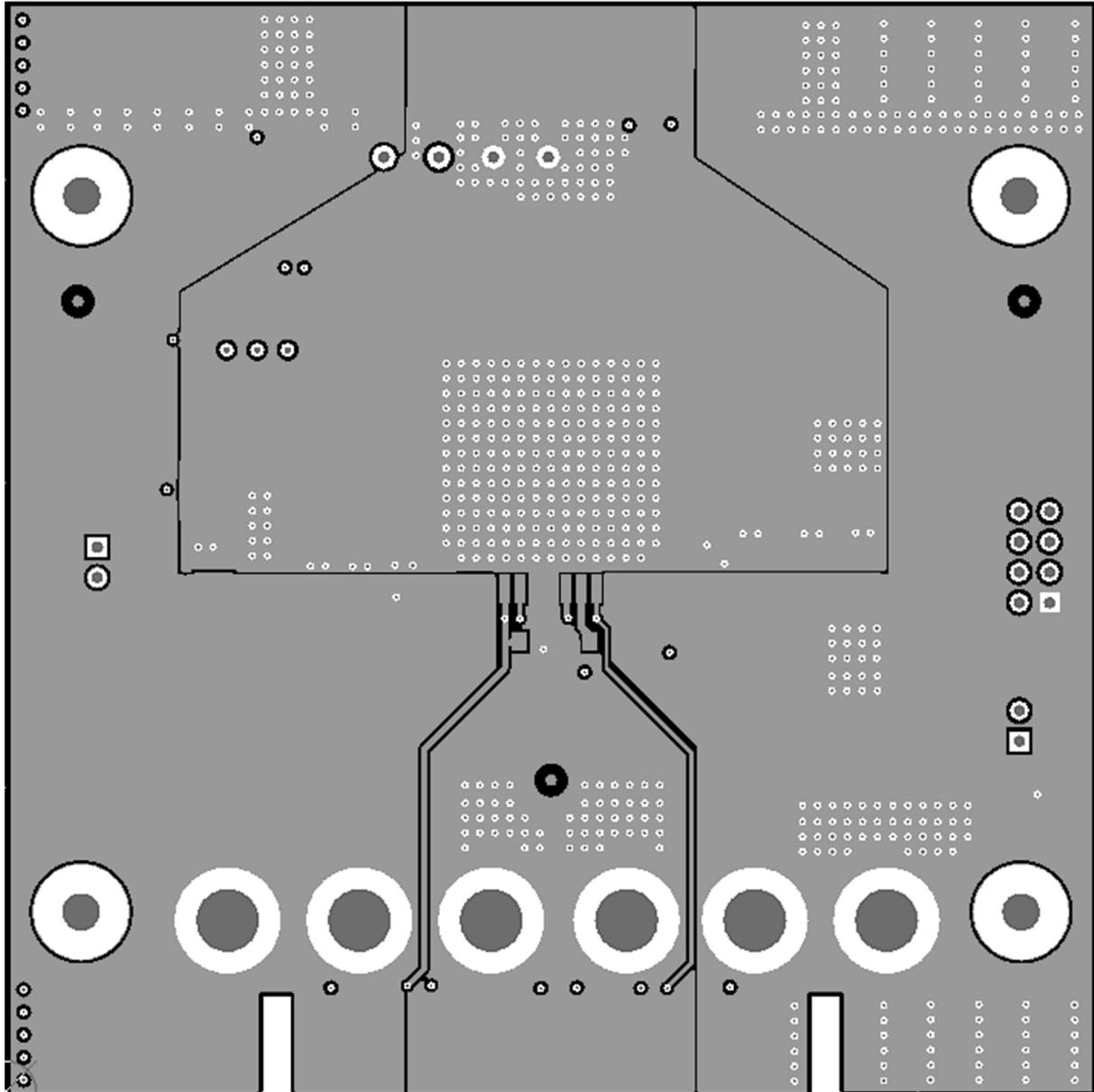

30138714

FIGURE 7. Top Layer

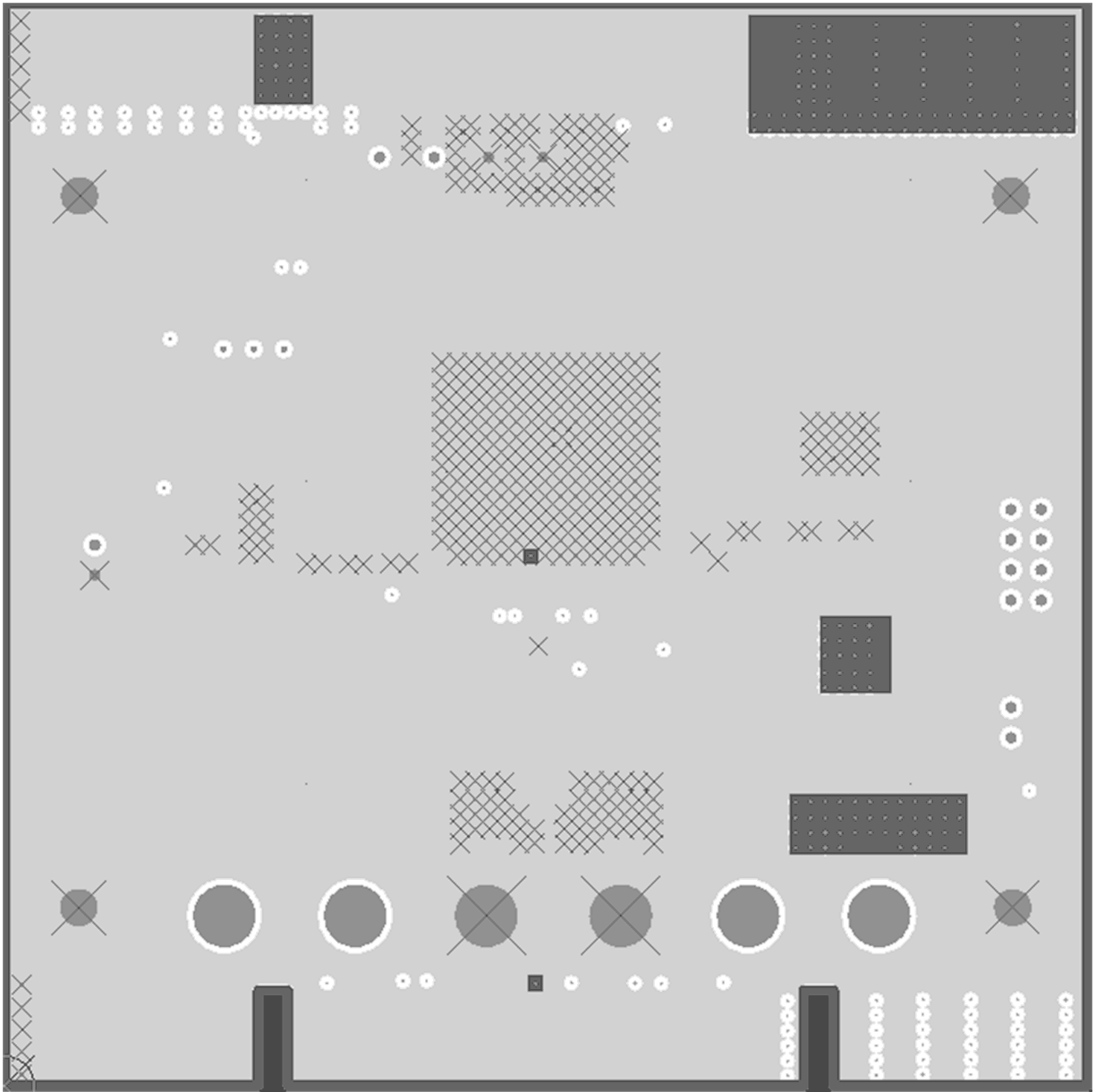

30138715

**FIGURE 8. Internal Layer I (Ground)  
Heat Sinking Layer**

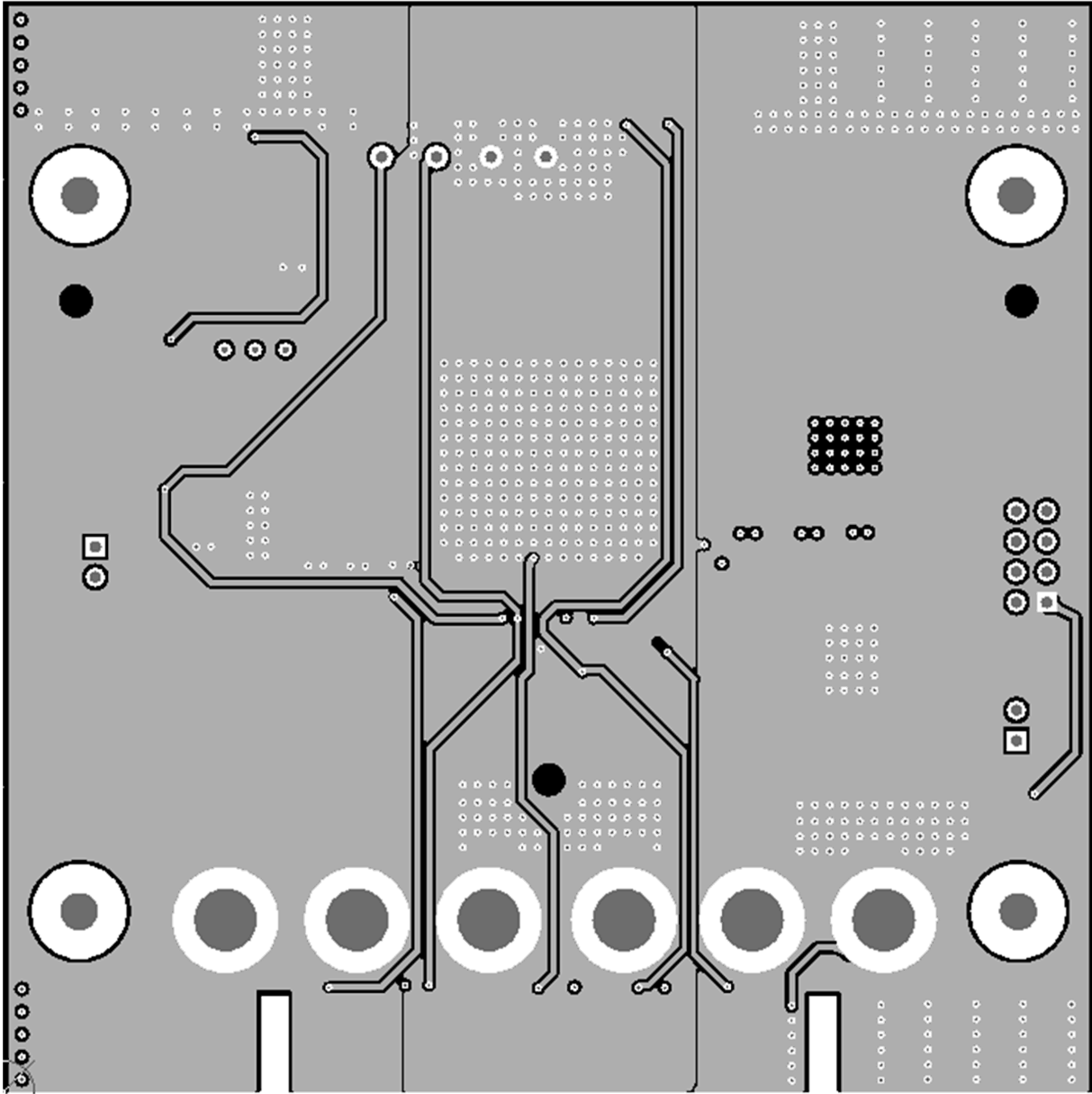

30138716

**FIGURE 9. Internal Layer II (Routing)  
Heat Sinking Layer**

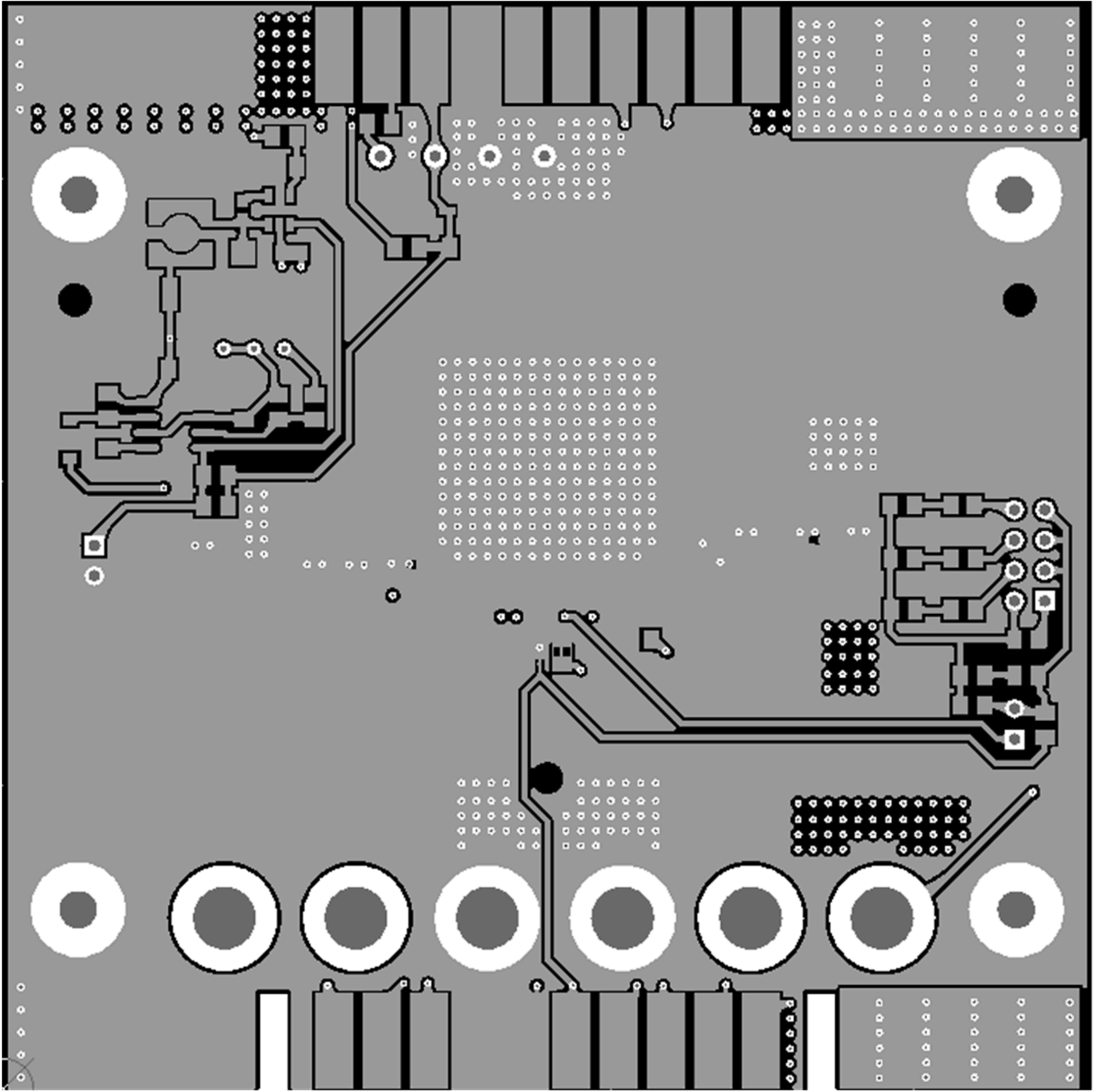

30138717

**FIGURE 10. Bottom Layer (Ground and Routing)  
Heat Sinking Layer**

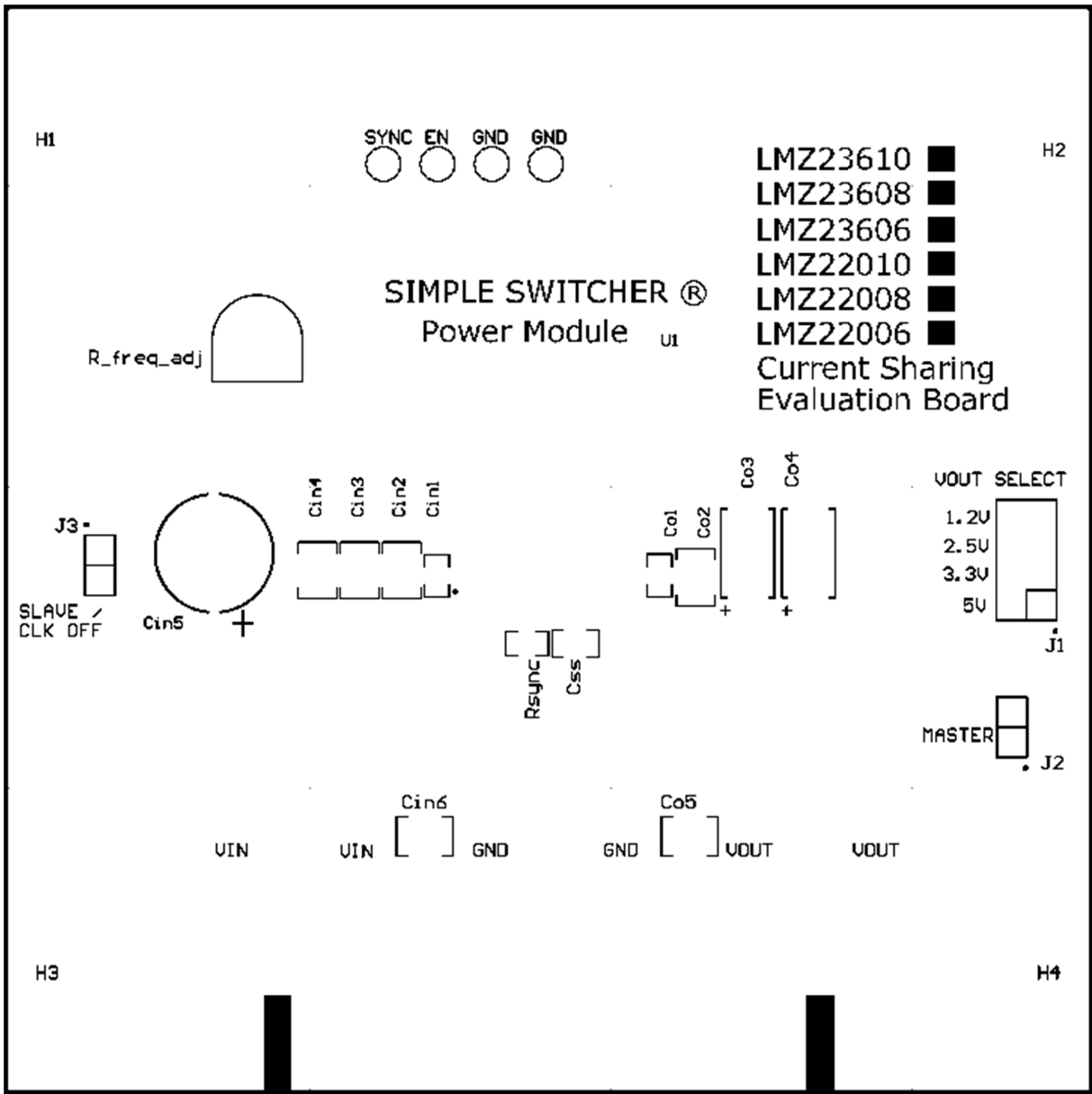

FIGURE 11. Top Silkscreen





# Notes

AN-2093

## Notes

For more National Semiconductor product information and proven design tools, visit the following Web sites at:  
[www.national.com](http://www.national.com)

Products		Design Support	
Amplifiers	<a href="http://www.national.com/amplifiers">www.national.com/amplifiers</a>	WEBENCH® Tools	<a href="http://www.national.com/webench">www.national.com/webench</a>
Audio	<a href="http://www.national.com/audio">www.national.com/audio</a>	App Notes	<a href="http://www.national.com/appnotes">www.national.com/appnotes</a>
Clock and Timing	<a href="http://www.national.com/timing">www.national.com/timing</a>	Reference Designs	<a href="http://www.national.com/refdesigns">www.national.com/refdesigns</a>
Data Converters	<a href="http://www.national.com/adc">www.national.com/adc</a>	Samples	<a href="http://www.national.com/samples">www.national.com/samples</a>
Interface	<a href="http://www.national.com/interface">www.national.com/interface</a>	Eval Boards	<a href="http://www.national.com/evalboards">www.national.com/evalboards</a>
LVDS	<a href="http://www.national.com/lvds">www.national.com/lvds</a>	Packaging	<a href="http://www.national.com/packaging">www.national.com/packaging</a>
Power Management	<a href="http://www.national.com/power">www.national.com/power</a>	Green Compliance	<a href="http://www.national.com/quality/green">www.national.com/quality/green</a>
Switching Regulators	<a href="http://www.national.com/switchers">www.national.com/switchers</a>	Distributors	<a href="http://www.national.com/contacts">www.national.com/contacts</a>
LDOs	<a href="http://www.national.com/ldo">www.national.com/ldo</a>	Quality and Reliability	<a href="http://www.national.com/quality">www.national.com/quality</a>
LED Lighting	<a href="http://www.national.com/led">www.national.com/led</a>	Feedback/Support	<a href="http://www.national.com/feedback">www.national.com/feedback</a>
Voltage References	<a href="http://www.national.com/vref">www.national.com/vref</a>	Design Made Easy	<a href="http://www.national.com/easy">www.national.com/easy</a>
PowerWise® Solutions	<a href="http://www.national.com/powerwise">www.national.com/powerwise</a>	Applications & Markets	<a href="http://www.national.com/solutions">www.national.com/solutions</a>
Serial Digital Interface (SDI)	<a href="http://www.national.com/sdi">www.national.com/sdi</a>	Mil/Aero	<a href="http://www.national.com/milaero">www.national.com/milaero</a>
Temperature Sensors	<a href="http://www.national.com/tempensors">www.national.com/tempensors</a>	SolarMagic™	<a href="http://www.national.com/solarmagic">www.national.com/solarmagic</a>
PLL/VCO	<a href="http://www.national.com/wireless">www.national.com/wireless</a>	PowerWise® Design University	<a href="http://www.national.com/training">www.national.com/training</a>

THE CONTENTS OF THIS DOCUMENT ARE PROVIDED IN CONNECTION WITH NATIONAL SEMICONDUCTOR CORPORATION ("NATIONAL") PRODUCTS. NATIONAL MAKES NO REPRESENTATIONS OR WARRANTIES WITH RESPECT TO THE ACCURACY OR COMPLETENESS OF THE CONTENTS OF THIS PUBLICATION AND RESERVES THE RIGHT TO MAKE CHANGES TO SPECIFICATIONS AND PRODUCT DESCRIPTIONS AT ANY TIME WITHOUT NOTICE. NO LICENSE, WHETHER EXPRESS, IMPLIED, ARISING BY ESTOPPEL OR OTHERWISE, TO ANY INTELLECTUAL PROPERTY RIGHTS IS GRANTED BY THIS DOCUMENT.

TESTING AND OTHER QUALITY CONTROLS ARE USED TO THE EXTENT NATIONAL DEEMS NECESSARY TO SUPPORT NATIONAL'S PRODUCT WARRANTY. EXCEPT WHERE MANDATED BY GOVERNMENT REQUIREMENTS, TESTING OF ALL PARAMETERS OF EACH PRODUCT IS NOT NECESSARILY PERFORMED. NATIONAL ASSUMES NO LIABILITY FOR APPLICATIONS ASSISTANCE OR BUYER PRODUCT DESIGN. BUYERS ARE RESPONSIBLE FOR THEIR PRODUCTS AND APPLICATIONS USING NATIONAL COMPONENTS. PRIOR TO USING OR DISTRIBUTING ANY PRODUCTS THAT INCLUDE NATIONAL COMPONENTS, BUYERS SHOULD PROVIDE ADEQUATE DESIGN, TESTING AND OPERATING SAFEGUARDS.

EXCEPT AS PROVIDED IN NATIONAL'S TERMS AND CONDITIONS OF SALE FOR SUCH PRODUCTS, NATIONAL ASSUMES NO LIABILITY WHATSOEVER, AND NATIONAL DISCLAIMS ANY EXPRESS OR IMPLIED WARRANTY RELATING TO THE SALE AND/OR USE OF NATIONAL PRODUCTS INCLUDING LIABILITY OR WARRANTIES RELATING TO FITNESS FOR A PARTICULAR PURPOSE, MERCHANTABILITY, OR INFRINGEMENT OF ANY PATENT, COPYRIGHT OR OTHER INTELLECTUAL PROPERTY RIGHT.

#### LIFE SUPPORT POLICY

**NATIONAL'S PRODUCTS ARE NOT AUTHORIZED FOR USE AS CRITICAL COMPONENTS IN LIFE SUPPORT DEVICES OR SYSTEMS WITHOUT THE EXPRESS PRIOR WRITTEN APPROVAL OF THE CHIEF EXECUTIVE OFFICER AND GENERAL COUNSEL OF NATIONAL SEMICONDUCTOR CORPORATION.** As used herein:

Life support devices or systems are devices which (a) are intended for surgical implant into the body, or (b) support or sustain life and whose failure to perform when properly used in accordance with instructions for use provided in the labeling can be reasonably expected to result in a significant injury to the user. A critical component is any component in a life support device or system whose failure to perform can be reasonably expected to cause the failure of the life support device or system or to affect its safety or effectiveness.

National Semiconductor and the National Semiconductor logo are registered trademarks of National Semiconductor Corporation. All other brand or product names may be trademarks or registered trademarks of their respective holders.

Copyright© 2011 National Semiconductor Corporation

For the most current product information visit us at [www.national.com](http://www.national.com)



**National Semiconductor  
Americas Technical  
Support Center**  
Email: [support@nsc.com](mailto:support@nsc.com)  
Tel: 1-800-272-9959

**National Semiconductor Europe  
Technical Support Center**  
Email: [europe.support@nsc.com](mailto:europe.support@nsc.com)

**National Semiconductor Asia  
Pacific Technical Support Center**  
Email: [ap.support@nsc.com](mailto:ap.support@nsc.com)

**National Semiconductor Japan  
Technical Support Center**  
Email: [jpn.feedback@nsc.com](mailto:jpn.feedback@nsc.com)

## IMPORTANT NOTICE

Texas Instruments Incorporated and its subsidiaries (TI) reserve the right to make corrections, modifications, enhancements, improvements, and other changes to its products and services at any time and to discontinue any product or service without notice. Customers should obtain the latest relevant information before placing orders and should verify that such information is current and complete. All products are sold subject to TI's terms and conditions of sale supplied at the time of order acknowledgment.

TI warrants performance of its hardware products to the specifications applicable at the time of sale in accordance with TI's standard warranty. Testing and other quality control techniques are used to the extent TI deems necessary to support this warranty. Except where mandated by government requirements, testing of all parameters of each product is not necessarily performed.

TI assumes no liability for applications assistance or customer product design. Customers are responsible for their products and applications using TI components. To minimize the risks associated with customer products and applications, customers should provide adequate design and operating safeguards.

TI does not warrant or represent that any license, either express or implied, is granted under any TI patent right, copyright, mask work right, or other TI intellectual property right relating to any combination, machine, or process in which TI products or services are used. Information published by TI regarding third-party products or services does not constitute a license from TI to use such products or services or a warranty or endorsement thereof. Use of such information may require a license from a third party under the patents or other intellectual property of the third party, or a license from TI under the patents or other intellectual property of TI.

Reproduction of TI information in TI data books or data sheets is permissible only if reproduction is without alteration and is accompanied by all associated warranties, conditions, limitations, and notices. Reproduction of this information with alteration is an unfair and deceptive business practice. TI is not responsible or liable for such altered documentation. Information of third parties may be subject to additional restrictions.

Resale of TI products or services with statements different from or beyond the parameters stated by TI for that product or service voids all express and any implied warranties for the associated TI product or service and is an unfair and deceptive business practice. TI is not responsible or liable for any such statements.

TI products are not authorized for use in safety-critical applications (such as life support) where a failure of the TI product would reasonably be expected to cause severe personal injury or death, unless officers of the parties have executed an agreement specifically governing such use. Buyers represent that they have all necessary expertise in the safety and regulatory ramifications of their applications, and acknowledge and agree that they are solely responsible for all legal, regulatory and safety-related requirements concerning their products and any use of TI products in such safety-critical applications, notwithstanding any applications-related information or support that may be provided by TI. Further, Buyers must fully indemnify TI and its representatives against any damages arising out of the use of TI products in such safety-critical applications.

TI products are neither designed nor intended for use in military/aerospace applications or environments unless the TI products are specifically designated by TI as military-grade or "enhanced plastic." Only products designated by TI as military-grade meet military specifications. Buyers acknowledge and agree that any such use of TI products which TI has not designated as military-grade is solely at the Buyer's risk, and that they are solely responsible for compliance with all legal and regulatory requirements in connection with such use.

TI products are neither designed nor intended for use in automotive applications or environments unless the specific TI products are designated by TI as compliant with ISO/TS 16949 requirements. Buyers acknowledge and agree that, if they use any non-designated products in automotive applications, TI will not be responsible for any failure to meet such requirements.

Following are URLs where you can obtain information on other Texas Instruments products and application solutions:

### Products

Audio	<a href="http://www.ti.com/audio">www.ti.com/audio</a>
Amplifiers	<a href="http://amplifier.ti.com">amplifier.ti.com</a>
Data Converters	<a href="http://dataconverter.ti.com">dataconverter.ti.com</a>
DLP® Products	<a href="http://www.dlp.com">www.dlp.com</a>
DSP	<a href="http://dsp.ti.com">dsp.ti.com</a>
Clocks and Timers	<a href="http://www.ti.com/clocks">www.ti.com/clocks</a>
Interface	<a href="http://interface.ti.com">interface.ti.com</a>
Logic	<a href="http://logic.ti.com">logic.ti.com</a>
Power Mgmt	<a href="http://power.ti.com">power.ti.com</a>
Microcontrollers	<a href="http://microcontroller.ti.com">microcontroller.ti.com</a>
RFID	<a href="http://www.ti-rfid.com">www.ti-rfid.com</a>
OMAP Mobile Processors	<a href="http://www.ti.com/omap">www.ti.com/omap</a>
Wireless Connectivity	<a href="http://www.ti.com/wirelessconnectivity">www.ti.com/wirelessconnectivity</a>

### Applications

Communications and Telecom	<a href="http://www.ti.com/communications">www.ti.com/communications</a>
Computers and Peripherals	<a href="http://www.ti.com/computers">www.ti.com/computers</a>
Consumer Electronics	<a href="http://www.ti.com/consumer-apps">www.ti.com/consumer-apps</a>
Energy and Lighting	<a href="http://www.ti.com/energy">www.ti.com/energy</a>
Industrial	<a href="http://www.ti.com/industrial">www.ti.com/industrial</a>
Medical	<a href="http://www.ti.com/medical">www.ti.com/medical</a>
Security	<a href="http://www.ti.com/security">www.ti.com/security</a>
Space, Avionics and Defense	<a href="http://www.ti.com/space-avionics-defense">www.ti.com/space-avionics-defense</a>
Transportation and Automotive	<a href="http://www.ti.com/automotive">www.ti.com/automotive</a>
Video and Imaging	<a href="http://www.ti.com/video">www.ti.com/video</a>

TI E2E Community Home Page

[e2e.ti.com](http://e2e.ti.com)

Mailing Address: Texas Instruments, Post Office Box 655303, Dallas, Texas 75265  
Copyright © 2011, Texas Instruments Incorporated