

AC - DC Power Modules

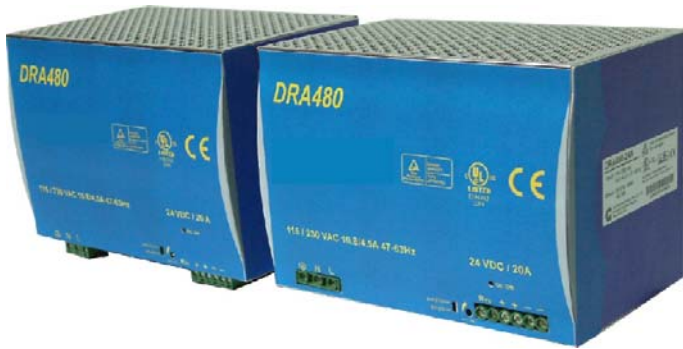

Features:

- Compact design
- High efficiency up to 90%
- Active PFC function
- Parallel function (switch selectable)
- Universal input voltage

AC - DC Din rail mountable
Industrial control equipment

Model List

Model No.	Input Voltage	Output Wattage	Output Voltage	Output Current	EFF. (Minimum)	EFF. (Typical)
Single Output Models						
DRA480-48A	90 to 264 V ac	480 W	+48 V dc	10 A	87%	90%

Specifications:

All specifications typical at nominal line, full load, 25°C unless otherwise noticed

General						
Characteristics	Conditions		Minimum	Typical	Maximum	Unit
Isolation Voltage	Input / output		3,000	-	-	V ac
Isolation Resistance	Input / output, at 500 V dc		100	-	-	MΩ
Ambient Temperature	Operating at Vi nom		-10	-	+71	°C
Derating	Vi nom, Io nom +61 to +71°C		-	-	2.5	% / °C
Storage Temperature	Non Operational		-25	-	+85	°C
Relative Humidity	Vi nom, Io nom		20	-	95	% RH
Dimension	Screw terminal type		L125 × W175 × D126			mm
	Detachable connector type		L142 × W175 × D126			
Cooling	Free air convection		-	-	-	-
Case Material	Metal		-	-	-	-

Input Specifications						
Characteristics	Conditions		Minimum	Typical	Maximum	Unit
Rated Input Voltage	Io nom		100	-	240	V ac
Input Voltage Range	Ta minimum to Ta maximum,	AC in	90	230	264	
	Io nom		DC in	120	-	370
Rated Input Current	Vi nom		Vi : 115 V ac	6.9	-	A
			Vi : 230 V ac	3.3	-	
Line Frequency	Vi nom, Io nom		47	-	63	Hz
Inrush Current	Vi nom, Io nom		Vi : 115 V ac	-	25	A
	Vi nom, Io nom		Vi : 230 V ac	-	50	
P.F.C.	Vi : 230 V ac, Io nom		-	0.99	-	-

AC - DC Power Modules



Output Specifications					
Characteristics	Conditions	Minimum	Typical	Maximum	Unit
Output Voltage Accuracy (Adjusted before shipment)	Vi nom, Io maximum	-0	-	+1	%
Minimum Load	Vi nom	0	-	-	
Line Regulation	Io nom, Vi minimum to Vi maximum	-	-	±0.5	
Load Regulation	Vi nom, Io nom to Io nom single mode	-	-	±1	
	Io minimum to Io nom parallel mode	-	-	±5	
Temperature Coefficient	Vi nom, Io minimum	-	-	±0.02	% / °C
Ripple and noise	Vi nom, Io nom, BW = 20 MHz	-	-	100	mV
Hold up Time	Vi nom, Io nom	35	-	-	ms
Voltage Trim Range	Vi nom, Io nom 48 V models	47	-	56	V dc
DC on Indicator Threshold at Start up	Vi nom, Io nom 48 V models	37	-	43	
DC Low Indicator Threshold at Start up	Vi nom, Io nom 48 V models		-		
Parallel Operation	0.9 Io maximum	-	-	3	Unit
Efficiency	Vi nom, Io nom, Po / Pi	Up to 90%, see model list			

Control and Protection					
Characteristics	Conditions	Minimum	Typical	Maximum	Unit
Input Fuse	-	10 A / 250 V ac internal			
Rated Over Load Protection	Vi nom	110	-	140	%
Power Rdy (for 24 V model only)	Threshold voltage of contact closed (at start up)	17.6	-	19.4	V dc
	Electrical isolation	500	-	-	
	Contact rating at 60 V dc	-	-	0.3	A
Over Voltage Protection	Vi nom, Io nom	120	-	145	%
Output Short Circuit	Vi nom	Continuous current limited			

Approvals and Standards	
UL / cUL	UL508 Listed, UL60950-1 Recognized
TUV	EN60950-1
CE	EN61000-6-3, EN55022 class B, EN61000-3-2, EN61000-3-3
	EN61000-6-2, EN55024

AC - DC Power Modules

Circuit Schematic

Block diagram for DRA480 series

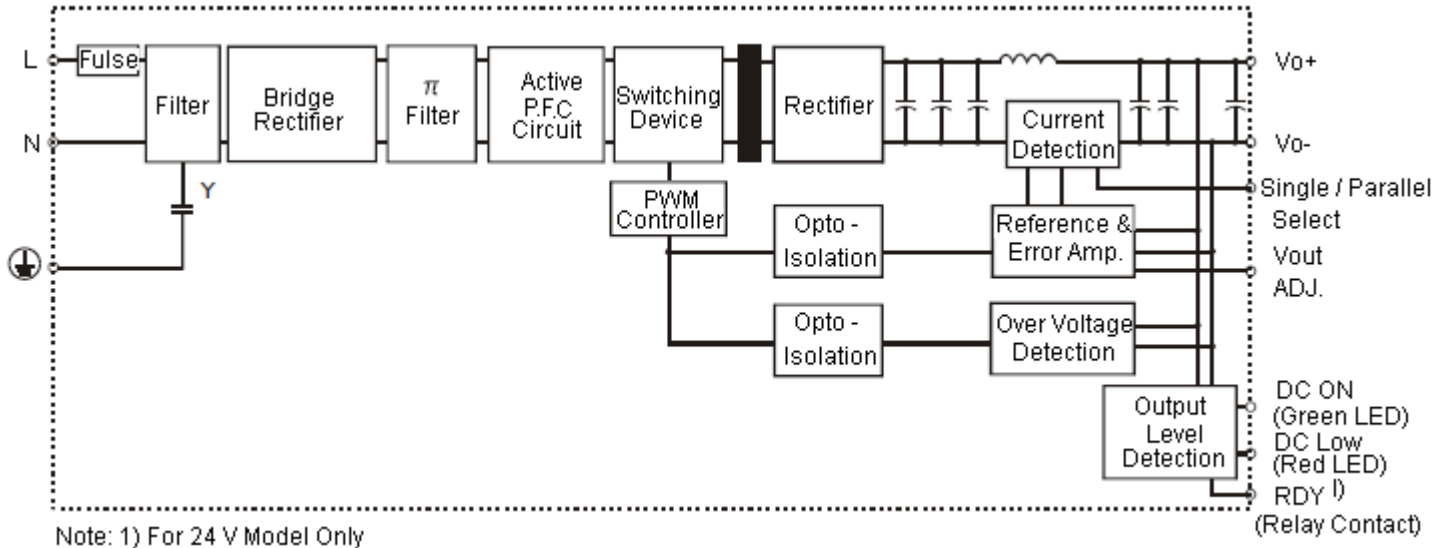

Physical Characteristics

Case Size	
Screw Terminal Type	: 125 × 175 × 126 mm 4.92 × 6.89 × 4.96 inches
Detachable Connector Type	: 142 × 175 × 126 mm 5.59 × 6.89 × 4.96 inches
Weight	: 1,800 g

Derating

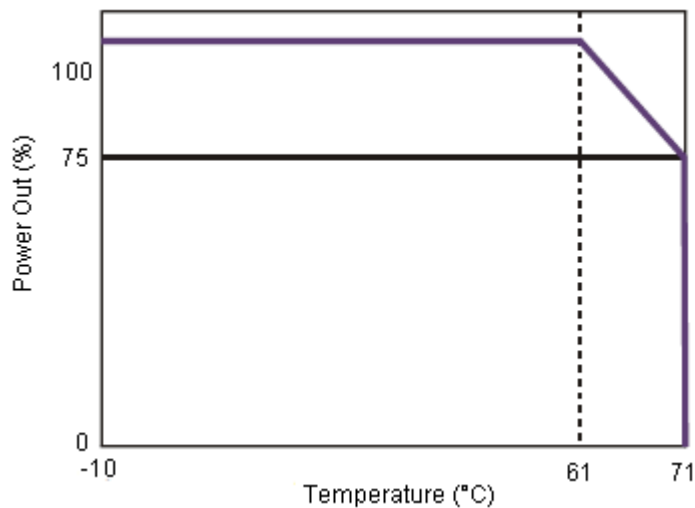

Mechanism and Pin Configuration

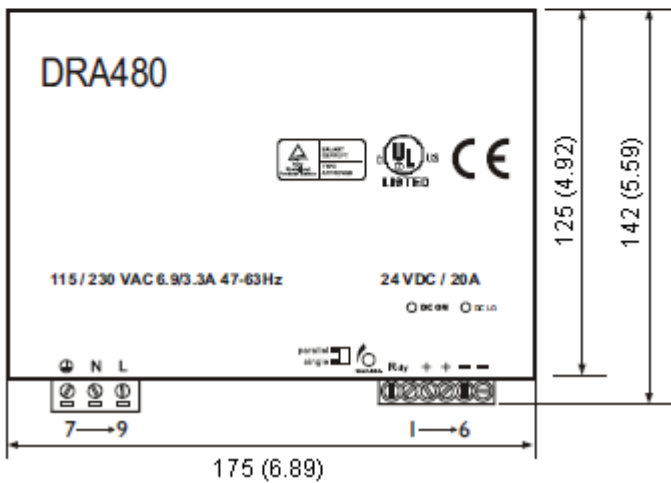
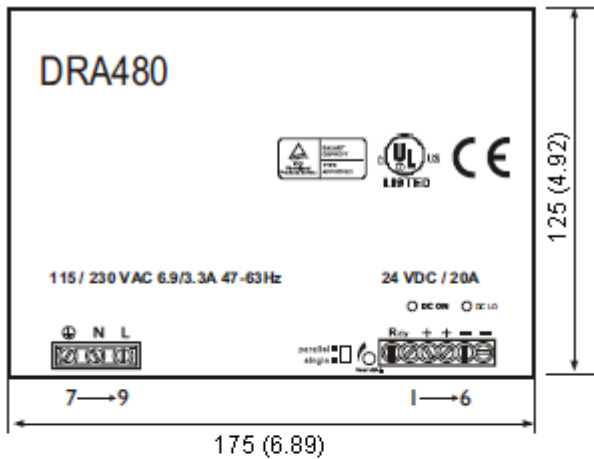

Dimensions : Millimetres (Inches)

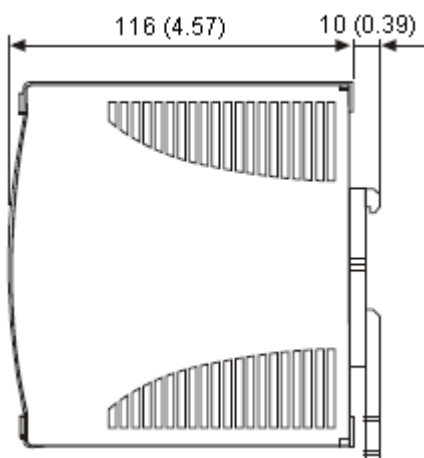

Dimensions : Millimetres (Inches)

Construction

Easy snap-on mounting onto the DIN-Rail (TS35/7.5 or TS35/15), unit sits safely and firmly on the rail

Installation

Ventilation / Cooling

Normal convection

All sides 25 mm free space

For cooling recommended

Connector size range

Screw terminal :

10 - 24 AWG flexible / solid cable, 8 mm stripping at cable end recommends

Detachable connector:

14 - 24 AWG flexible / solid cable, 7 mm stripping at cable end recommends

AC - DC Power Modules



Pin Assignment

Pin Number	Designation	Description	
1	Out	RDY A normal open relay contact for DC ON level control (Only for 24 V model)	
2			
3		V+	Positive output terminal
4		V+	
5		V-	Negative output terminal
6		V-	
7	In	 Ground this terminal to minimize high-frequency emissions	
8		N Input terminals (neutral conductor, no polarity at DC input)	
9		L Input terminals (phase conductor, no polarity at DC input)	
	Other	DC ON Operation indicator LED	
		DC LO DC LOW voltage indicator LED	
		Vout ADJ. Trimmer-potentiometer for Vout adjustment	
		S / P Single / Parallel select switch	

Part Number Table

Description	Part Number
PSU, Din Rail, 480 W, 48 V	DRA480-48A

Important Notice : This data sheet and its contents (the "Information") belong to the members of the Premier Farnell group of companies (the "Group") or are licensed to it. No licence is granted for the use of it other than for information purposes in connection with the products to which it relates. No licence of any intellectual property rights is granted. The Information is subject to change without notice and replaces all data sheets previously supplied. The Information supplied is believed to be accurate but the Group assumes no responsibility for its accuracy or completeness, any error in or omission from it or for any use made of it. Users of this data sheet should check for themselves the Information and the suitability of the products for their purpose and not make any assumptions based on information included or omitted. Liability for loss or damage resulting from any reliance on the Information or use of it (including liability resulting from negligence or where the Group was aware of the possibility of such loss or damage arising) is excluded. This will not operate to limit or restrict the Group's liability for death or personal injury resulting from its negligence. Multicomp is the registered trademark of the Group. © Premier Farnell plc 2012.