

Neon Indicator



Features:

- The neon is rear panel mounting and snaps into the lens making a simple and secure mounting. An appropriate resistor is incorporated in the body moulding.
- Termination 200mm PVC flexible leads.
- Quick, simple assembly operation.
- Lens snaps through panel onto indicator.
- Won't pull or vibrate off.
- High brightness neon incorporated.

Specifications:

Description	: Red, amber and green indicator.
Voltage Rating	: 220 to 250V ac.
Life	: >30,000 hours for neon lamp 20,000 hours minimum for neon lamp (3151-81-00A-RED).

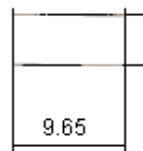
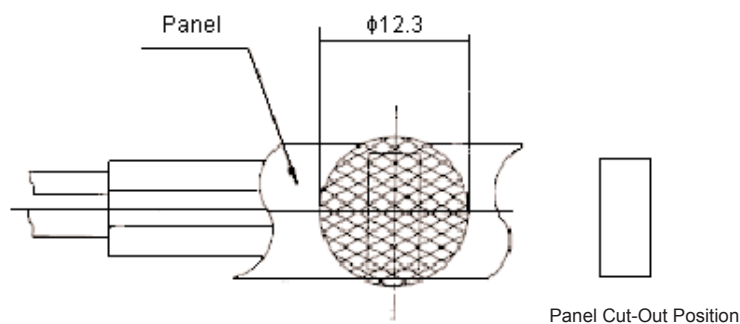
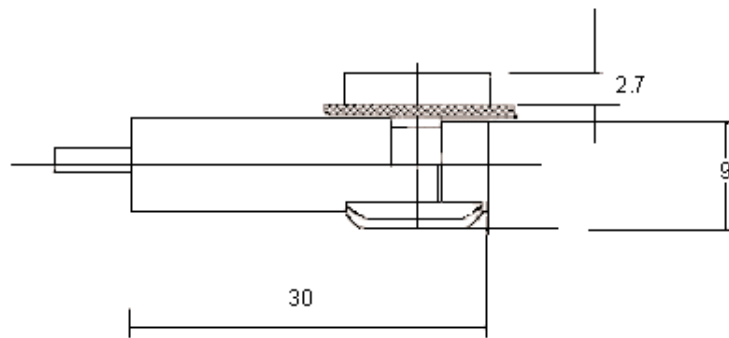

Panel Thickness = 2.0 Maximum

Dimensions : Millimetres

www.element14.com
www.farnell.com
www.newark.com



Neon Indicator



Dimensions : Millimetres

Part Number Table

Description	Length (Excluding Leads)	Depth Behind Panel	Lens Diameter	Panel Cut-Out Diameter	Maximum Panel Thickness	Colour	Part Number
Neon Indicator - Rear Panel Mounting	31	9	2.5 × 12.0	9.5	2.0	Red	3151-81-02A
	30	9.2	2.3			Amber	3151-81-03A
	31	9	2.5 × 12.0			Green	3151-82-05A

Dimensions : Millimetres

Important Notice : This data sheet and its contents (the "Information") belong to the members of the Premier Farnell group of companies (the "Group") or are licensed to it. No licence is granted for the use of it other than for information purposes in connection with the products to which it relates. No licence of any intellectual property rights is granted. The Information is subject to change without notice and replaces all data sheets previously supplied. The Information supplied is believed to be accurate but the Group assumes no responsibility for its accuracy or completeness, any error in or omission from it or for any use made of it. Users of this data sheet should check for themselves the Information and the suitability of the products for their purpose and not make any assumptions based on information included or omitted. Liability for loss or damage resulting from any reliance on the Information or use of it (including liability resulting from negligence or where the Group was aware of the possibility of such loss or damage arising) is excluded. This will not operate to limit or restrict the Group's liability for death or personal injury resulting from its negligence. Multicomp is the registered trademark of the Group. © Premier Farnell plc 2012.

www.element14.com
www.farnell.com
www.newark.com

