

CORNING

LANscape®

Installation Guide for the TKT-UNICAM-PFC Tool Kit

www.corning.com/cablesystems/unicam

US and Canada: 1-800-743-2671

International: +1-828-901-5000

006-369
Issue 6

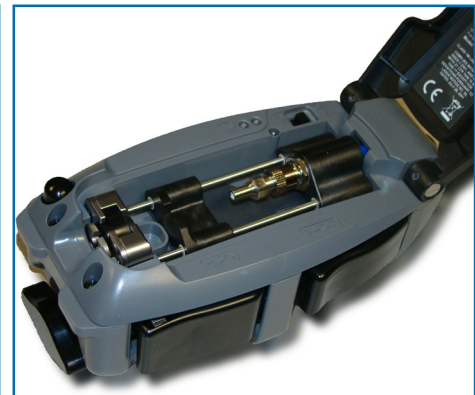

Corning Cable Systems LLC

PO Box 489
Hickory, NC 28603-0489 USA
FAX: 828-325-5060

www.corning.com/cablesystems

Corning Cable Systems reserves the right to improve, enhance, and modify the features and specifications of Corning Cable Systems' products without prior notification. UniCam is a registered trademark of Corning Cable Systems Brands, Inc. ST is a registered trademark of Lucent Technologies. All other trademarks are the properties of their respective owners. Corning Cable Systems is ISO 9001 certified.

© 2007, 2008, 2010 Corning Cable Systems. All rights reserved. Published in the USA.
SRP 006-369, Issue 6 / July 2010

Table of Contents

Introduction	v
Safety Precautions	vii
1. Getting Started	1
1.1. General	1
1.2. High-Performance UniCam® Tool Kit Contents	1
1.3. Compatible Connectors and Ordering Information	2
2. Overview of Installation Tools	5
2.1. High-Performance UniCam Installation Tool	5
2.2. FBC-015 Cleaver	7
3. Tool and Connector Preparation	9
3.1. Tool Preparation	9
3.2. Connector Preparation	10
3.3. Connector Loading	11
4. Fiber Preparation	15
4.1. All Fiber/Cable Types	15
4.2. 900 micron Tight-buffered Fibers	15
4.3. Jacketed Cable	17
4.4. 900 micron Fan-out Tubing Applications	20
5. Fiber Cleaving with FBC-015 Cleaver	21
5.1. Cleaving Procedure	21

6.	Connector Termination	23
6.1.	Termination Process	23
6.2.	Completing the Connector Assembly	26
7.	Maintenance and Troubleshooting	29
7.1.	High-Performance Installation Tool	29
7.2.	Maintaining the FBC-015 Cleaver	32
7.3.	Connector Cleaning	33
7.4.	Troubleshooting	34
7.5.	Testing UniCam® Connectors	36

Introduction

This manual describes how to assemble Corning Cable Systems UniCam® LC, SC, and ST® Compatible connectors. This document describes installation of both multimode and single-mode connectors.

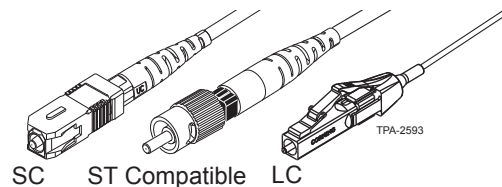
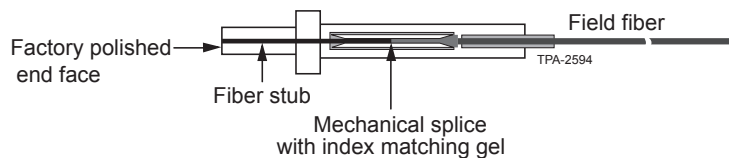

Please become familiar with the entire manual before starting to assemble a connector.

Visit www.corning.com/cablesystems/unicam for more information and videos showing this procedure.

THIS PAGE INTENTIONALLY LEFT BLANK.

Safety Precautions

Optical Fiber Precautions



WARNING: Cleaved or broken glass fibers are very sharp and can pierce the skin or damage the eyes easily. Do not let pieces of fiber stick to your clothing or drop in the work area where protect your eyes. Use tweezers to pick up pieces of fiber and place them on a loop of tape kept for that purpose alone. Good housekeeping is very important.

Chemical Precautions



CAUTION: Fiber Optic Cleaning Fluid can cause irritation to eyes on contact. In case of eye contact, immediately flush eyes with water for at least 15 minutes. Inhaling fumes may be harmful. Use with adequate ventilation. In case of ingestion, consult a physician.

Laser Handling Precautions



WARNING: **Never look directly into the end of a fiber that may be carrying laser light.** Laser light can be invisible and can damage your eyes. Viewing it directly does not cause pain. The iris of the eye will not close involuntarily as when viewing a bright light. Consequently, serious damage to the retina of the eye is possible. Should accidental eye exposure to laser light be suspected, arrange for an eye examination immediately.

Safety Glasses Precautions



CAUTION: Recommend the use of safety glasses (spectacles) conforming to ANSI Z87, for eye protection from accidental injury when handling chemicals, cables, or working with fiber. Pieces of glass fiber are very sharp and have the potential to damage the eye.

Laser Safety

The High-Performance UniCam® Installation tool conforms to the requirements contained in IEC 60825-1:1993 plus Amendments 1:1997 and 2:2001. $P_{max} < 1.0 \text{ mW}$, $\lambda=635\text{nm}$

LASER LIGHT

DO NOT VIEW DIRECTLY WITH OPTICAL INSTRUMENTS (MAGNIFIERS).

CLASS 1M LASER PRODUCT



CAUTION: Use of controls or adjustments or performance of procedures other than those specified herein may result in hazardous radiation exposure.

Cable Handling Precautions

NOTE: Fiber optic cable is sensitive to excessive pulling, bending, and crushing forces. Consult the cable specification sheet for the cable you are installing. Do not bend the cable more sharply than the minimum recommended bend radius. Do not apply more pulling force to the cable than specified. Do not crush the cable or allow it to kink. Doing so may cause damage that can alter the transmission characteristics of the cable; the cable may have to be replaced.

For additional safety information, please visit www.corning.com/cablesystems/safety.

1. GETTING STARTED

1.1. General

Please become familiar with the appropriate sections of this manual before starting to install a connector.

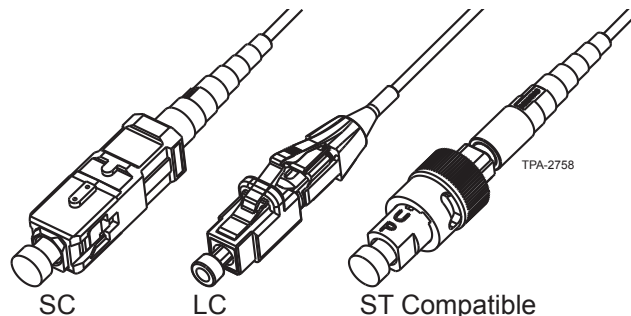

1.2. High-Performance UniCam® Tool Kit Contents

Table 1 describes the contents of the Corning Cable Systems High-Performance UniCam® Tool Kit.

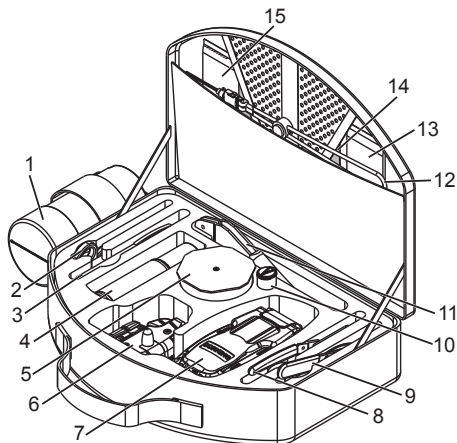

Number	Item	Part Number
1	UniCam Tool Kit Trash Container	2104498-01
2	Scissors	100294-01
3	Retractable Black Permanent Marker	2104499-01
4	Fiber Optic Cleaning Fluid	FCC-CLEANER-FIBER
5	Fiber Wipes	FCC-WIPES
6	High-Performance Cleaver	FBC-015
7	High-Performance UniCam Installation Tool	TL-UCP
8	Cable Jacket Stripping Tool	3206001-01
9	Dual-hole Stripping Tool	2104502-01
10	1.25 mm Ferrule Adapter	VFL-A125 *
11	UniCam Crimp Tool	3201007-01
12	Lanyards (2)	02-002853-001
13	Cleaning Stick - Size 1.25 mm	CLEAN-STICKS-125
14	Strip Length Gauge	02-001757-001
15	Cleaning Stick - Size 2.5 mm	CLEAN-STICKS-250
Not Shown	Installation Instructions for SC, LC, ST® Compatible Connectors	006-369
Not Shown	2.5 mm Ferrule Adapter (ships in the Installation Tool)	VFL-A250 *

* Order both Ferrule Adapters by referencing VFL-AK1T

TPA-2761

1.3. Compatible Connectors and Ordering Information

	Part Number	Description
SC	95-000-40	SC Standard Performance Multimode (OM1)
	95-000-41	SC High Performance Multimode (OM1)
	95-050-40	SC Standard Performance Multimode (OM2)
	95-050-41	SC High Performance Multimode (OM2)
	95-050-41-X	SC High Performance Multimode (OM3, OM4)
	95-200-41	SC Single-Mode UPC (OS2)
	95-200-44	SC Single-Mode APC (OS2)
ST [®] Compatible	95-000-50	ST Compatible Standard Performance Multimode (OM1)
	95-000-51	ST Compatible High Performance Multimode (OM1)
	95-050-50	ST Compatible Standard Performance Multimode (OM2)
	95-050-51	ST Compatible High Performance Multimode (OM2)
	95-050-51-X	ST Compatible High Performance Multimode (OM3, OM4)
	95-200-51	ST Compatible Single-Mode UPC (OS2)
LC	95-000-99	LC High Performance Multimode (OM1)
	95-050-99	LC High Performance Multimode (OM2)
	95-050-99-X	LC High Performance Multimode (OM3, OM4)
	95-200-99	LC Single-Mode UPC (OS2)

NOTE: To order an organizer pack containing 25 connectors, add -Z to desired part number above (e.g., 95-000-50-Z)

Keyed LC solutions are also available. Visit www.corning.com/cablesystems and enter "LAN-701-EN" into the search engine for detailed information.

1.3.1 Components

Each UniCam® connector package contains the parts shown in this section of the manual.

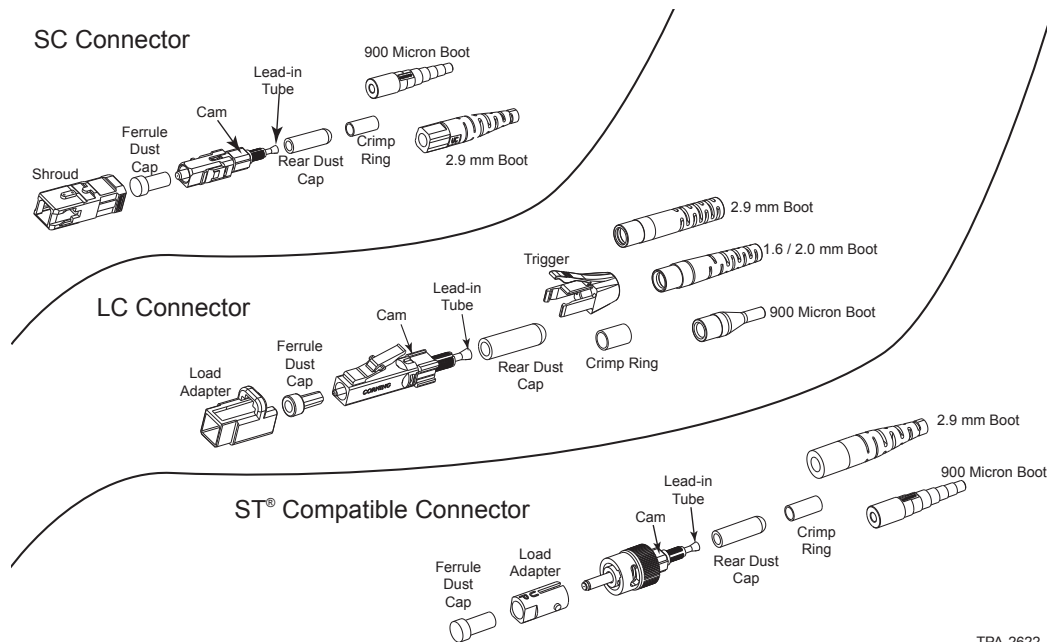

TPA-2622

NOTE: Organizer packs only include materials for 900 micron termination.

THIS PAGE INTENTIONALLY LEFT BLANK.

2. OVERVIEW OF INSTALLATION TOOLS

This chapter provides an overview of the tools required for installing SC, LC, and ST® Compatible UniCam® connectors.

2.1. High-Performance UniCam Installation Tool

2.1.1 General

This section describes the components of the High-Performance UniCam Installation Tool.

NOTE: With the exception of the Ferrule Adapter, this tool operates independent of the connector or fiber type. SC and ST Compatible connectors require use of the 2.5 mm adapter and LC connectors require the 1.25 mm adapter.

Please read through this entire chapter before using the installation tool to install UniCam connectors. Refer to Chapters 3, 4, and 5 for complete operating instructions.

2.1.2 Features and Components

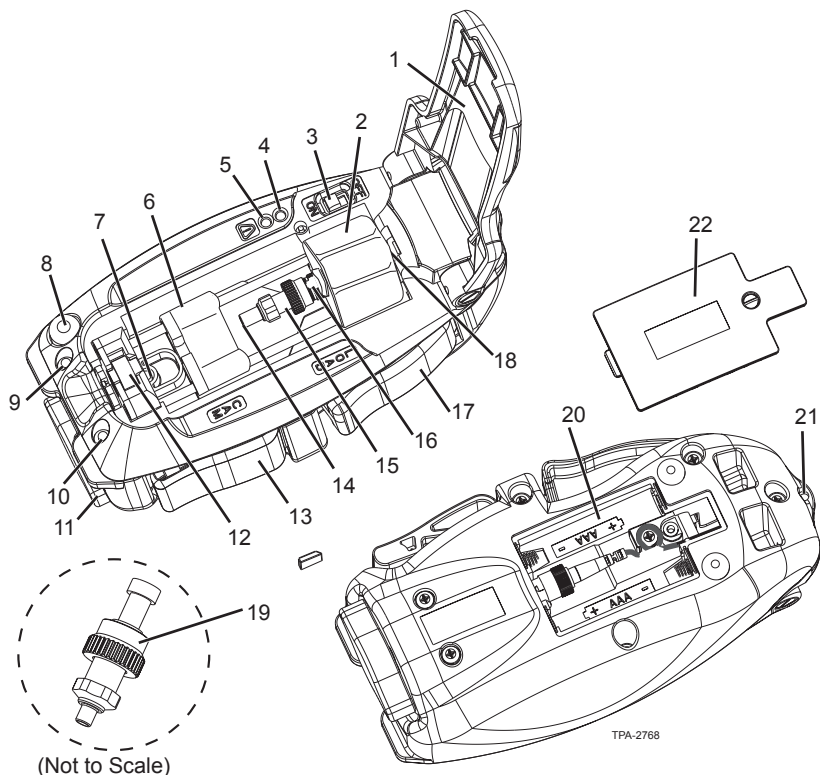

Number	Components
1	Cover
2	VFL Coupler
3	Power Switch
4	Power Light
5	Error Light
6	Connector Cradle
7	Photo Receptor
8	Reset Button
9	Red Light
10	Green Light
11	Crimp Knob
12	Wrench
13	CAM Button
14	Laser Aperture
15	2.50 mm Ferrule Adapter (ships in the tool)
16	Ferrule Adapter Port
17	LOAD Button
18	Jumper
19	1.25 mm Ferrule Adapter (ships in the toolkit)
20	Battery Compartment
21	Lanyard Attachment
22	Battery Cover

2.2. FBC-015 Cleaver

2.2.1 General

This section describes the components of the FBC-015 Cleaver. Please read through this entire chapter, the Fiber Preparation chapter, and Fiber Cleaving chapter before using the cleaver. Refer to Chapter 5 for complete operating instructions and precautions.

2.2.2 Features and Components

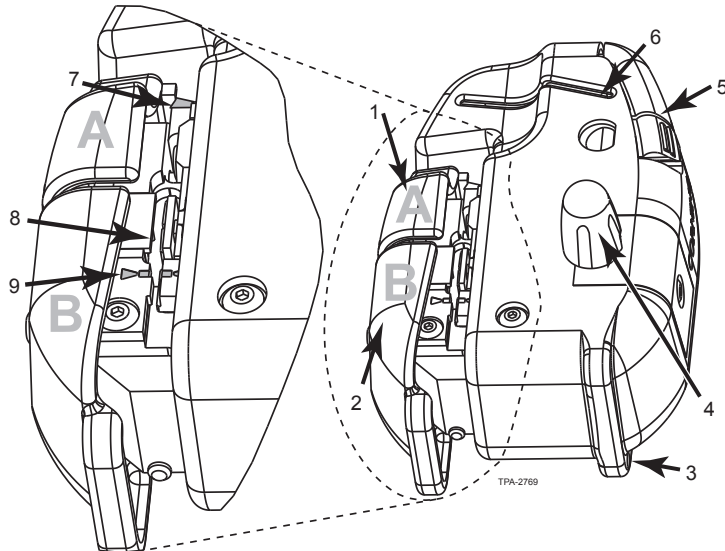

Number	Components
1	Button A
2	Button B
3	Lanyard Hole
4	Blade Knob
5	Scrap Bin
6	Scrap Fiber Slot
7	V-Groove
8	Blade
9	Alignment Mark

THIS PAGE INTENTIONALLY LEFT BLANK.

3. TOOL AND CONNECTOR PREPARATION

3.1. Tool Preparation

Tool is designed to be held in the left hand while working.

3.1.1 Open the Cover

Step 1: Ensure the components are in the starting position. If not:

- Slide the VFL Coupler back toward the cover hinge until it locks.
- Verify the LOAD Button is released and the Connector Cradle is against its travel stop.
- Depress the Reset Button to return the Wrench to the start position.

Step 2: Ensure that the correct Ferrule Adapter is installed.

- 2.5 mm for SC and ST® Compatible connectors
- 1.25 mm for LC connectors
- To change the adapter, refer to "Section 7.1.2 Ferrule Adapter" on page 29.

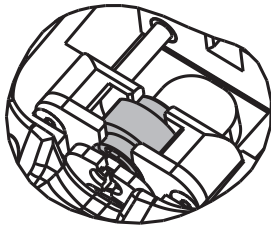

Start Position - Wrench Closed

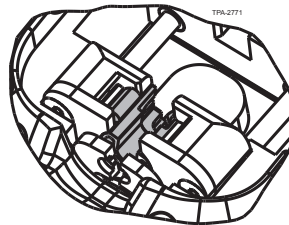

Finished Position - Wrench Open - Press Reset Button

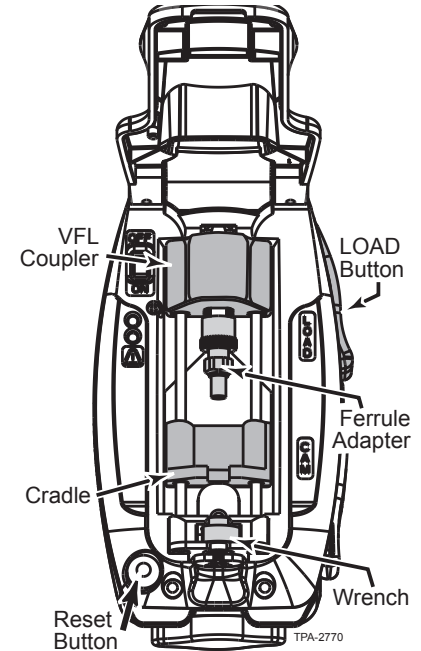

3.1.2 Switch Power On

Step 1: Locate power switch and light in the upper left corner of the tool.

Step 2: Move the switch to the ON position. Once the tool is on, the Power Light will glow.

- If the Power Light flashes or does not glow, the batteries need to be replaced.
- Refer to “Section 7.1.1 Changing the Batteries” on page 29 for battery replacement instructions.

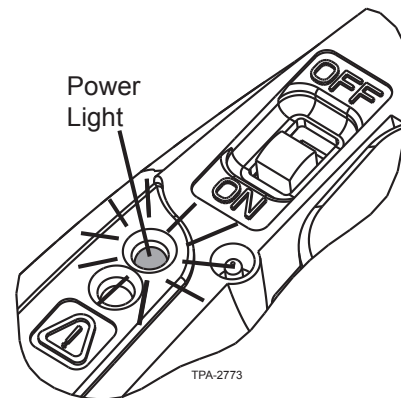

3.2. Connector Preparation

3.2.1 Verify Cam Position

Because the connector cam may rotate slightly during shipment, verify that the connector cam is in the open position. The cam is open when the cam key is 90 degrees from:

- SC connectors - the date code when it is facing up
- LC connectors - the latch when it is facing up
- ST® Compatible connectors - the “UP” label molded on the load adapter

NOTE: If the cam is not in the open position, the connector will not fit correctly into the installation tool.

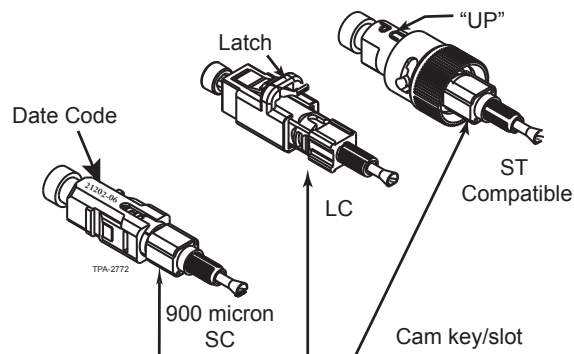

3.2.2 Prepare Connector for Loading

- Step 1:** Remove the rear dust cap.
- Step 2:** Remove the clear ferrule dust cap and visually inspect the connector for damage.
- Step 3:** Leave the black load adapter on LC and ST® Compatible connectors until after termination.

3.3. Connector Loading

- Step 1:** Squeeze the LOAD Button to move the Connector Cradle away from the Wrench.

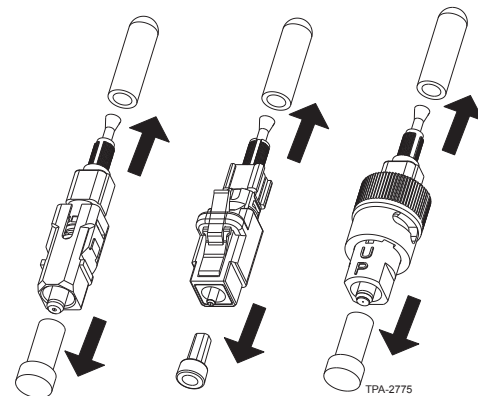
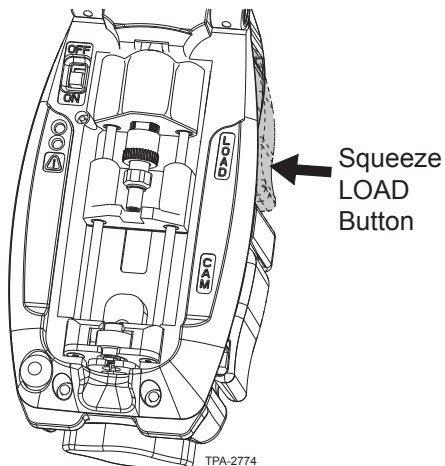

Step 2: With the connector oriented up (as shown on page 10), load the connector into the tool by inserting it, lead-in tube first, into the Wrench.

NOTE: Ensure that the cam is completely seated in the Wrench and the lead-in tube protrudes through the crimp arms. The flare of the lead-in tube should be visible beyond the crimp arms.

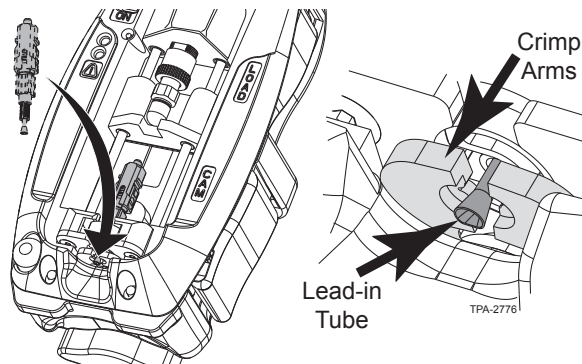

Step 3: Slowly release the LOAD button while guiding the connector into the Connector Cradle. Ensure the connector is firmly seated in the Cradle.

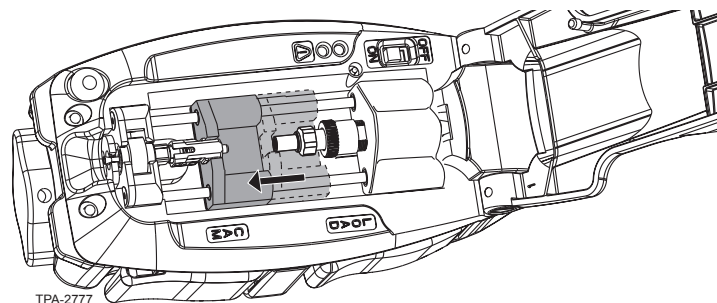

Step 4: Slide the VFL Coupler down until the Ferrule Adapter is seated on the connector.

Step 5: Close the cover and check for the Error Light.

- If the Error Light remains off, there are no problems. Proceed to “Section 4. Fiber Preparation” on page 15
- If the Error Light flashes, refer to “Section 7.4. Troubleshooting” on page 34.

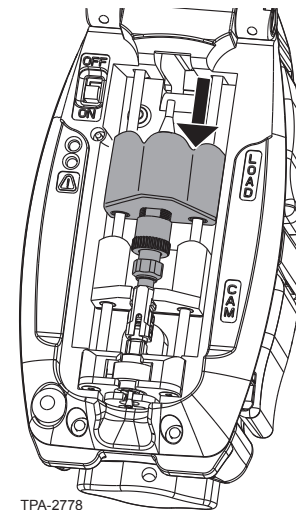
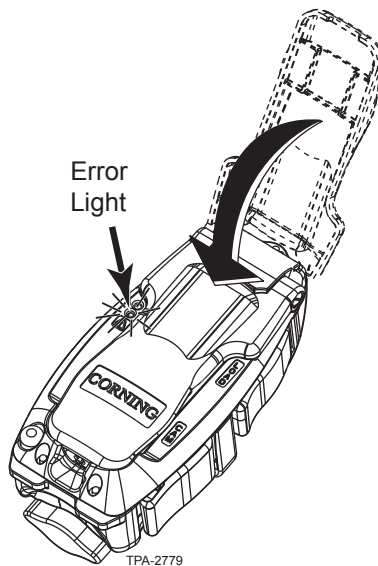

Step 6: Set the installation tool aside and prepare the field fiber for termination.

THIS PAGE INTENTIONALLY LEFT BLANK.

4. FIBER PREPARATION

4.1. All Fiber/Cable Types

Slide the appropriate boot onto the fiber/cable.

- Use the 900 micron boot for 900 micron Tight-buffered, 900 micron Furcated.
- Use the 1.6, 2.0, or 2.9 mm cable boot for Jacketed Cable applications.
- For LC connectors, also slide the trigger onto the fiber/cable after installing the boot.

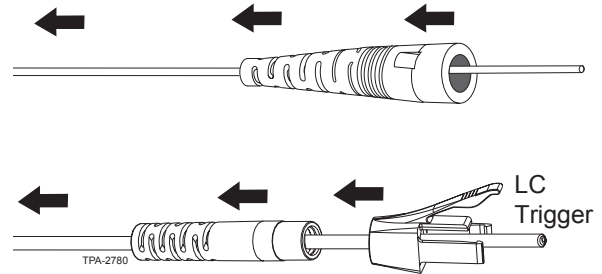

4.2. 900 micron Tight-buffered Fibers

Step 1: Using the Strip Length Gauge and permanent marker, measure and mark 40 mm from the end of the buffered fiber.

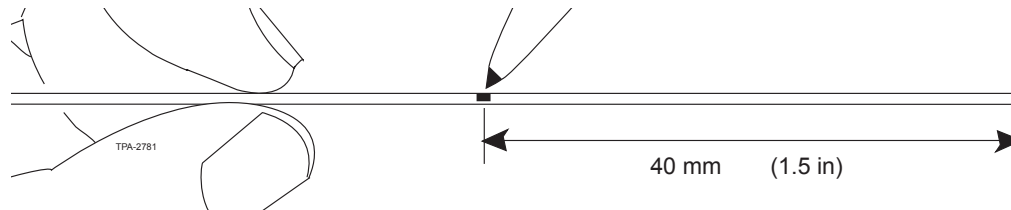

Step 2: To expose bare glass, remove the 40 mm section of buffer and coating in two steps using the Dual-Hole Miller Tool.

- For the 900 micron buffer, use the large hole.
- For the 250 micron coating, use the small hole.

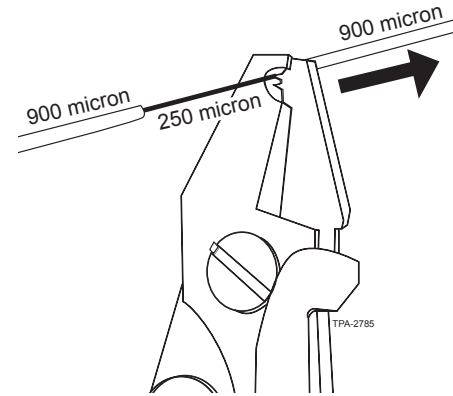
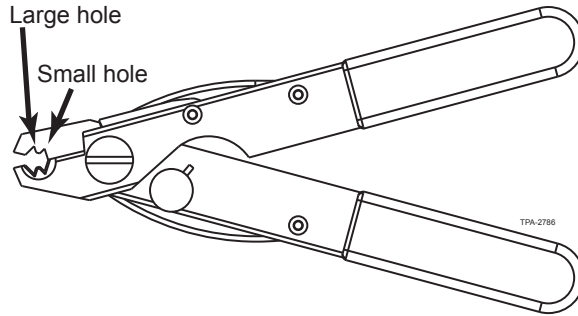

Step 3: For SC and ST® Compatible connectors, measure and place a visual mark on the buffer an additional 11 mm back from the end of the buffer. For LC connectors, measure and mark the buffer an not a9 mm back.

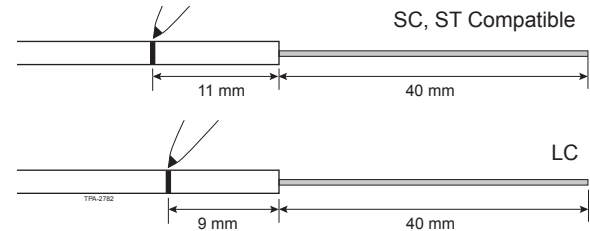

Step 4: Clean the bare fiber with two passes of a Fiber Wipe dampened with Fiber Optic Cleaning Fluid.

Do not touch the bare fiber after cleaning it. Do not remove the visual mark.

Step 5: Proceed to Chapter 5, Fiber Cleaving.

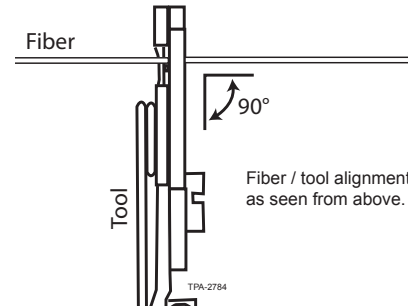

4.3. Jacketed Cable

NOTE: Take your time to do the following four steps correctly. Excessive yarn length will have to be trimmed later. Yarn too short may result in weak strain-relief for the connector.

Step 1: Measure and mark 40 mm and 53 mm points.

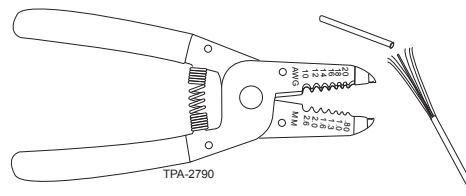
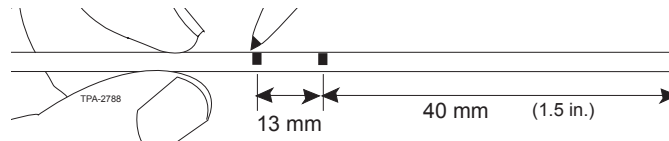
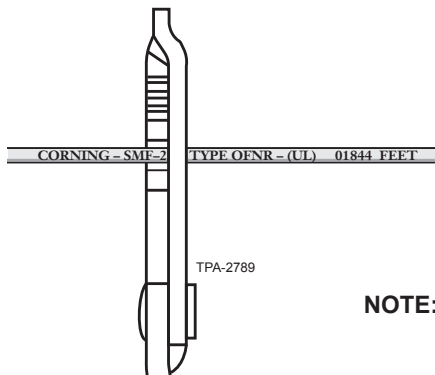

NOTE: When using this tool to strip buffers, do NOT attempt to slide severed tube or jacket off the fibers with the sliding motion commonly used to strip copper wire with this tool. Doing so may break the fibers.

Step 2: Refer to table for the correct AWG opening for the cable being used and strip off the 40 mm section of outer jacket with the Jacket Stripping Tool.

Step 3: Use scissors to trim the aramid yarn flush with the end of the outer jacket.

Step 4: Strip off the 13 mm section of outer jacket, exposing 13 mm of aramid yarn using the Jacket Stripping Tool.

Step 5: Fold the aramid yarn back over the cable jacket and slide the crimp ring about 5 mm down the yarn to hold it out of the way.

Step 6: Mark the 900 micron buffer:

- For SC and ST® Compatible connectors, mark 900 micron buffer 11 mm from the end of the cable jacket and at the edge of the cable jacket.
- For LC connectors, mark the 900 micron buffer 11 mm and 2 mm from the edge of the cable jacket.

NOTE: The second mark is a visual aid to indicate when the field fiber contacts the fiber stub.

Cable Jacket Diameter	AWG Size
1.6 mm	20
2.0 mm	18
2.9 mm	16

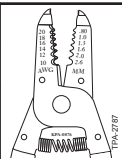
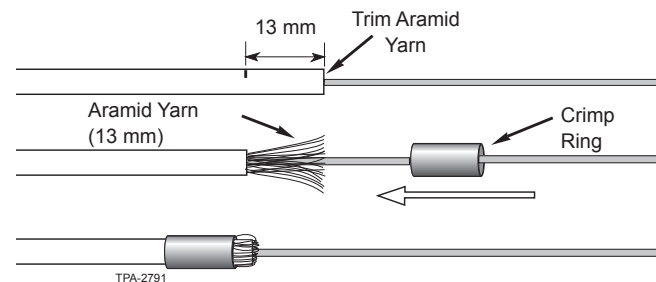
SC and ST Compatible

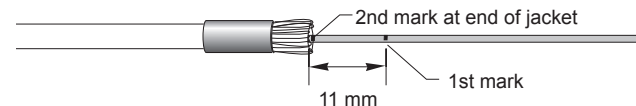

LC

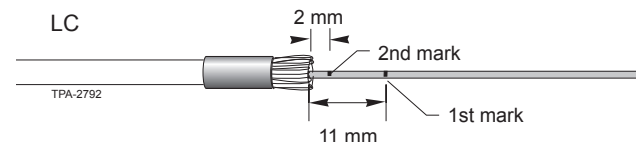

Step 7: Use the Dual-Hole Miller Tool to remove the 40 mm of buffer and coating in two steps: (same as step 3 from section 4.3).

NOTE: It is IMPORTANT to check the locations of the second mark after stripping. For SC and ST[®] Compatible connectors, the mark must be near the edge of the jacket; for LC connectors, the mark must be within 2 mm from the edge of the jacket. If necessary, work the buffer back into its original position in the jacket as follows:

- Grasp the cable several inches behind the strip point.
- Pull the cable until the second mark is near its starting position -
 - SC and ST[®] Compatible: near the edge of the jacket.
 - LC: within 2 mm of the edge of the jacket.

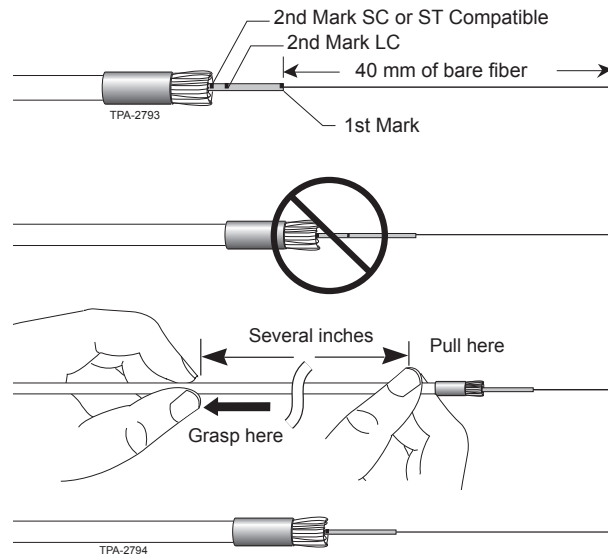

Step 8: Clean the bare fiber with two passes of a Fiber Wipe dampened with Fiber Optic Cleaning Fluid. Do not touch the bare fiber after cleaning it. Do not remove the visual mark.

Step 9: Proceed to Section 5, "Fiber Cleaving with FBC-015 Cleaver" on page 21.

4.4. 900 micron Fan-out Tubing Applications

Step 1: Remove the 900 micron tubing with Dual-Hole Miller Tool or trim back the fiber so that 44 mm of fiber protrudes from the 900 micron tubing.

Step 2: Measure and mark the 250 micron coated fiber 4 mm from the end of the fan-out tubing.

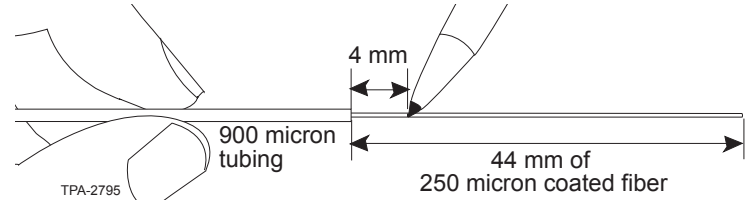

Step 3: Measure and mark the fan-out tube:

- SC and ST® Compatible connectors: 11 mm back from the end of the 900 micron tubing.
- LC connectors: 9 mm back from the end of the 900 micron tubing.

Step 4: Remove the 250 micron coating to the 4 mm mark using the small hole on the Dual-Hole Miller Tool. It is important to leave 4 mm of 250 micron fiber extending beyond the 900 micron tubing to allow the fibers to touch before the 900 micron tubing bottoms out inside the connector and to ensure a good cleave with the FBC-015.

Step 5: Clean the bare fiber with two passes of a Fiber Wipe dampened with Fiber Optic Cleaning Fluid. Do not touch the bare fiber after cleaning it. Do not remove the visual mark.

Step 6: Proceed to Section 5, “Fiber Cleaving with FBC-015 Cleaver” on page 21.

5. FIBER CLEAVING WITH FBC-015 CLEAVER

5.1. Cleaving Procedure

Step 1: Ensure that both clamps are clean and free of fiber. Refer to Chapter 7, Maintenance and Troubleshooting for instructions on cleaning the clamps.

Step 2: Squeeze buttons A and B at the same time to open the clamps.

Step 3: Place the fiber in the slot so the:

- Bare fiber is in the V-groove,
- The buffer or coating is aligned with the alignment mark, and
- The fiber rests under the tab.

NOTE: When terminating fan-out tubing, align the 250 micron coated fiber with the alignment mark.

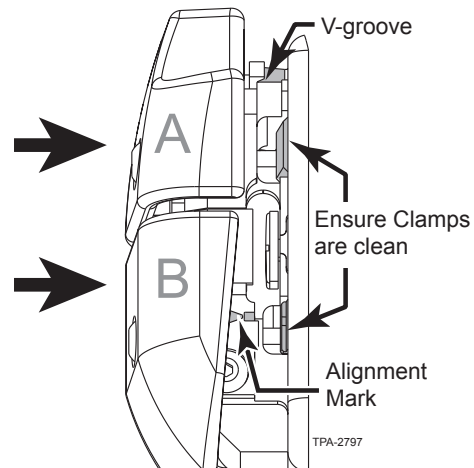
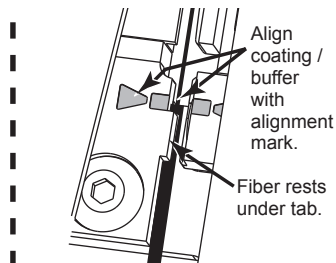
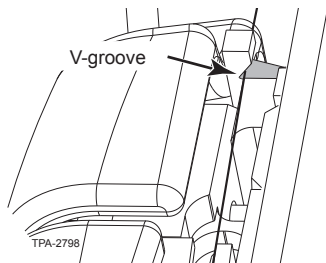

Step 4: Fully release Button B, then release Button A. Ensure that both the bare and coated fiber is secured by the clamps.

Step 5: Slowly turn the knob 360 degrees to cleave the fiber.

Step 6: Squeeze Button A, remove the scrap fiber, and place it in the scrap fiber bin.

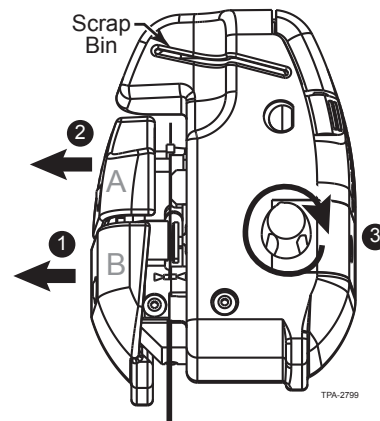

Step 7: While holding onto the fiber, squeeze Button B and remove the cleaved fiber.

NOTE: Once the fiber is cleaved, do not clean the fiber or allow it to contact anything. If the cleaved fiber does contact something, repeat fiber preparation and re-cleave.

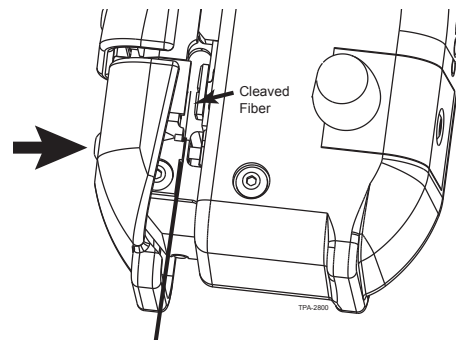

6. CONNECTOR TERMINATION

6.1. Termination Process

NOTE: THE COVER MUST BE CLOSED FOR THE SYSTEM TO FUNCTION.

Step 1: Insert a cleaved fiber into the back of the lead-in tube. Insert the fiber until you feel it firmly stop against the fiber stub. The visual mark on the fiber should be within 2 mm of the lead-in tube.

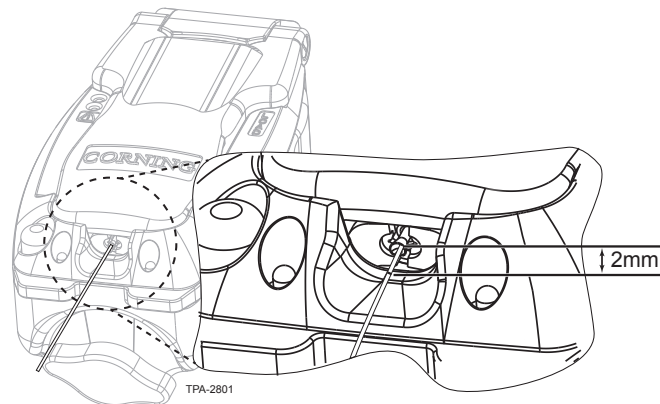

Step 2: While maintaining enough inward pressure to create a slight bend in the fiber, squeeze the CAM button until it locks.

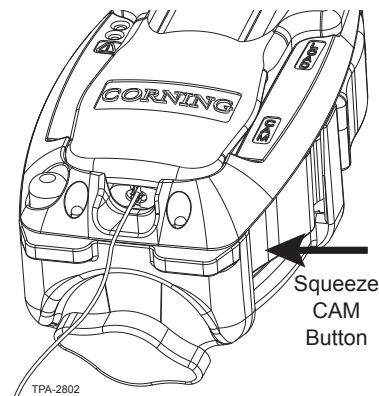

Step 3: Check the termination lights.

- If the green light is illuminated, the termination was successful. Proceed to Step 4.

NOTE: The green light ensures proper termination of the connector. However, it is not a substitute for system testing.

Do NOT press the reset button until the connector is removed from the tool.

- If the red light is illuminated, the termination was not successful.
 - a. Press the Reset Button and remove the fiber. Repeat the termination process at Step 1 on page 21.
 - b. If the red light illuminates again, step (a).
 - c. If the red light continues to illuminate after two termination attempts, press the Reset Button and remove the fiber. Repeat steps starting at appropriate fiber preparation step in Section “4. Fiber Preparation” on page 15.
 - d. If unable to achieve a successful termination, refer to the Troubleshooting section in Chapter 7 of this manual.

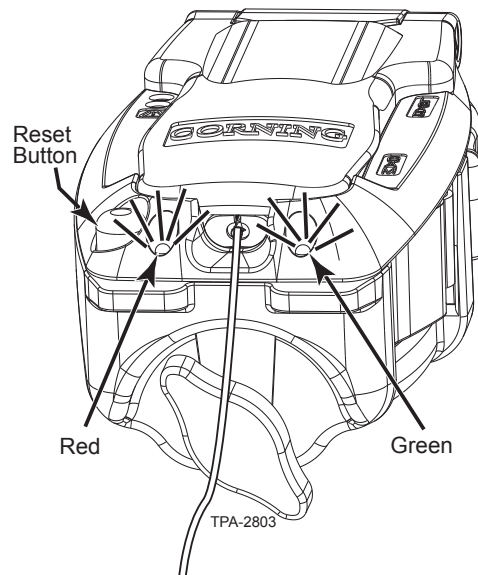

Step 4: Release fiber and turn the Crimp Knob 180 degrees in either direction.

- There may be slight resistance while turning the knob; this is normal.
- Turning the Crimp Knob crimps the lead-in tube onto the fiber, thus locking the connector to the fiber.

NOTE: Do NOT press the reset button until the connector is removed from the tool.

Step 5: Open the cover and gently slide the VFL Coupler back into its starting position (1). The coupler shouldn't move freely if this is done correctly.

Step 6: Slightly squeeze the LOAD Button to remove the connector (2). Lift straight up on the connector and reinstall the clear ferrule dust cap (3).

Step 7: Press the Reset Button to make the tool ready for the next connector (4). If the cover is closed at this point without a connector loaded, the Error Light will flash. This is an indication that there is no connector in the tool. Once a connector is correctly loaded and the cover closed, the light will stop flashing.

Step 8: When finished installing connectors, press the Reset Button, slide the Power Switch to the OFF position, ensure VFL Coupler is in the starting position, close the cover, and return the tool to the tool kit.

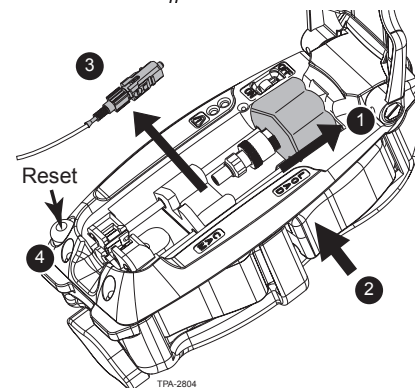
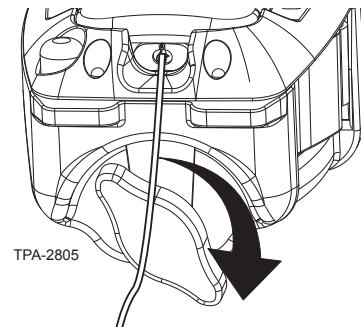

6.2. Completing the Connector Assembly

Complete the connector assembly process by following the appropriate steps below for your connector type.

NOTE: If not using on Jacketed Cables skip Section 6.2.1 and proceed to the section for your connector type.

6.2.1 Jacketed Cables

Step 1: Ensure the ferrule dust cap is installed.

Step 2: Hold the cable and slide the crimp ring back along the cable jacket to free the aramid yarn.

Step 3: Flare the yarn around the connector. The ends of the yarn should just touch the back of the square cam. If the yarn is too long, trim it now.

Step 4: Hold the connector and push the crimp ring over the aramid yarn and against the back of the connector's cam.

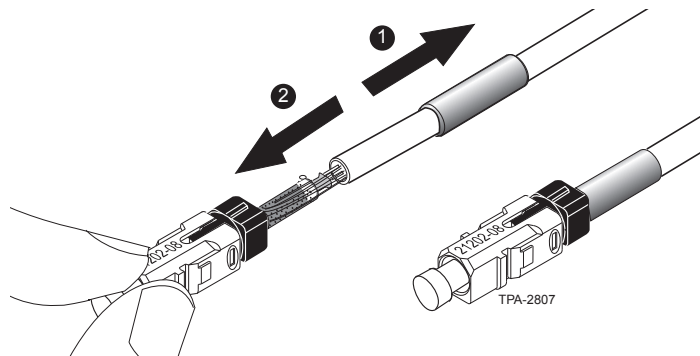

NOTE: Use only the crimp tool supplied with the UniCam® tool kit (p/n 3201007-01). Other similar-appearing crimp tools (such as tools with part numbers 3201001-01 and 3201002-01) will over-crimp causing increased attenuation.

- Step 5:** Place the connector crimp ring into the opening of the crimp tool jaws.
- Step 6:** Squeeze the handles shut until they automatically release, indicating completion of the crimp. Remove the connector and cable from the tool.
- Step 7:** Proceed to the description for your connector type below to complete the connector assembly.

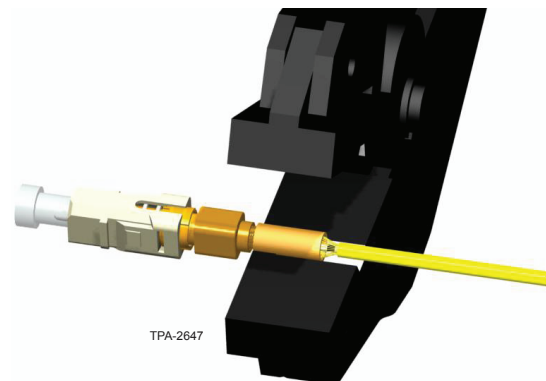

6.2.2 SC Connectors

- Step 1:** Ensure the clear ferrule dust cap is installed.
- Step 2:** Slide the boot up the back of the connector until it reaches the cam.
- Step 3:** Install the outer shroud by lining up the date code with the key-side of the outer shroud. Using the boot, push the UniCam assembly into the outer shroud until it snaps into place.

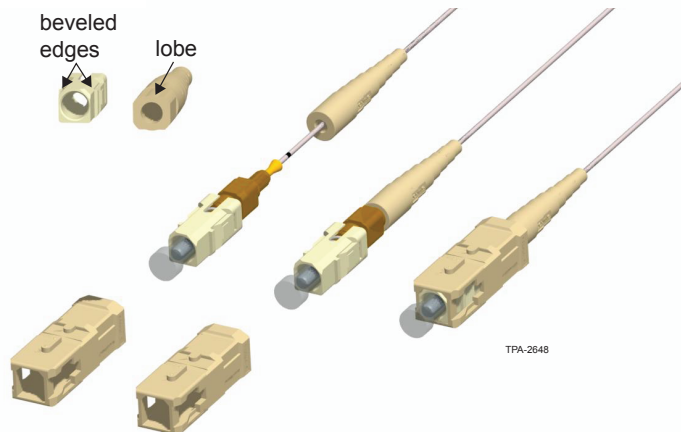

6.2.3 LC Connectors

- Step 1:** Ensure the clear ferrule dust cap is installed.
- Step 2:** Remove the black load adapter.
- Step 3:** Slide the trigger up to the back of the connector and latch its arms into the windows of the housing.
- Step 4:** While holding the connector by the front dust cap, slide the correct strain-relief boot up the back of the connector and under the trigger until it stops.

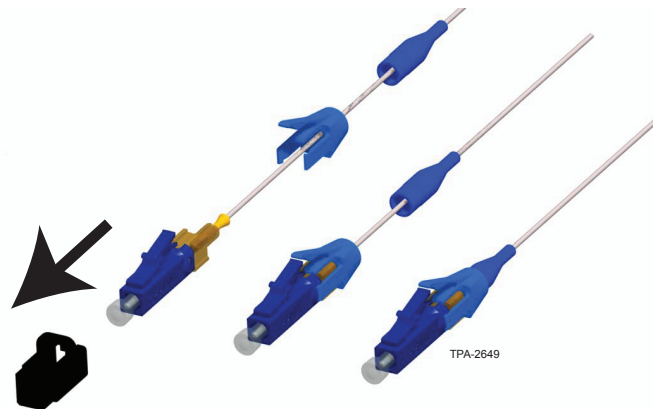

6.2.4 ST® Compatible Connectors

- Step 1:** Remove the black load adapter.
- Step 2:** Reinstall the clear ferrule dust cap.
- Step 3:** Slide the boot up the back of the connector until it reaches the cam.

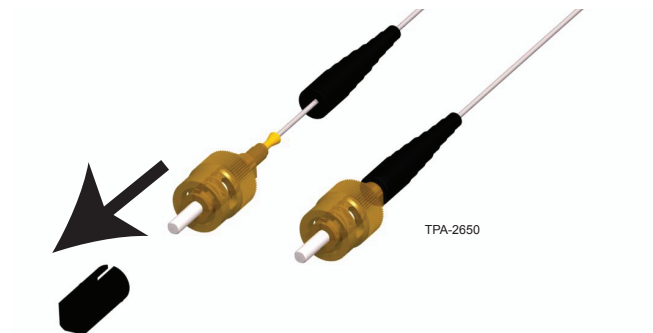

7. MAINTENANCE AND TROUBLESHOOTING

This section provides maintenance and troubleshooting information for the High-Performance Installation Tool, FBC-015 Cleaver, and UniCam® connectors.

7.1. High-Performance Installation Tool

7.1.1 Changing the Batteries

Step 1: Verify the tool is turned off.

Step 2: Locate the battery cover on the bottom of the tool.

Step 3: Remove the battery cover using a standard flat-head screwdriver.

NOTE: Be careful not to disturb the jumper.

Step 4: Replace the two AAA batteries following the polarity indicators.

Step 5: Replace the battery cover and tighten the screw, being careful not to overtighten.

7.1.2 Ferrule Adapter

Cleaning the Ferrule Adapter

NOTE: NOTE: It is recommended to clean the Ferrule Adapter after every 100 connector installations. Use the adapter cleaning sticks provided in the toolkit.

Step 1: Select the correct size stick:

1.25 mm adapter - Small stick

2.5 mm adapter - Large stick

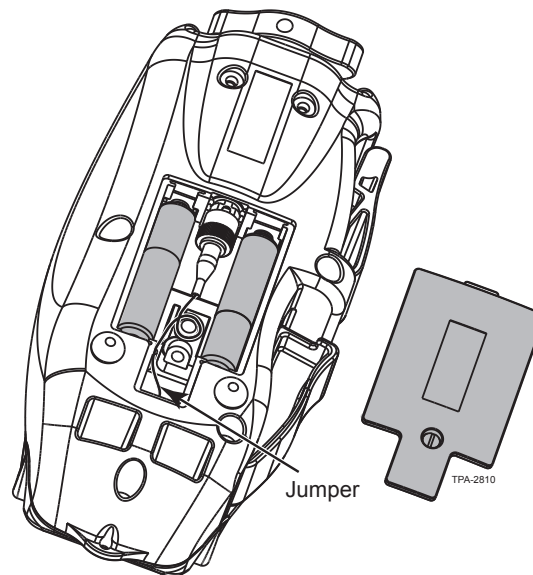

- Step 2:** Insert the stick into the adapter opening and rotate the tip clockwise 10 revolutions.
- Step 3:** Apply varying pressures to create a gentle pumping action.
- Step 4:** Dispose of each cleaning stick after use. Do not use sticks more than once.

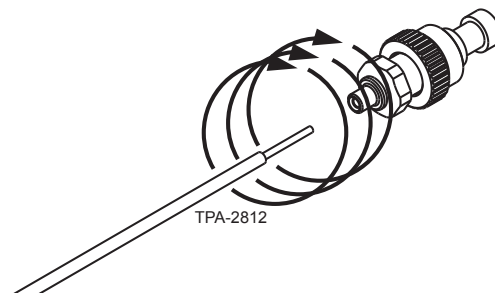

Replacing the Ferrule Adapter

- Step 1:** Verify the tool is turned off.
- Step 2:** Unscrew the Adapter Coupling Nut from the Ferrule Adapter Port.
- Remove the adapter by pulling it straight out.
 - Swap the clear ferrule dust cap from the replacement adapter and then place in the vial.
- Step 3:** Clean the ferrule on the ferrule adapter per the instructions given in Section 7.3.

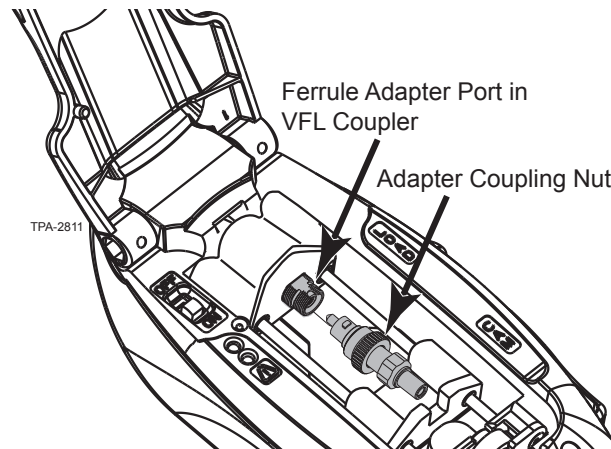

Step 4: Install the new Ferrule Adapter onto the Ferrule Adapter Port in the VFL Coupler.

Step 5: Be sure the key on the Ferrule Adapter is aligned with the keyway on the Ferrule Adapter Port, and then tighten firmly.

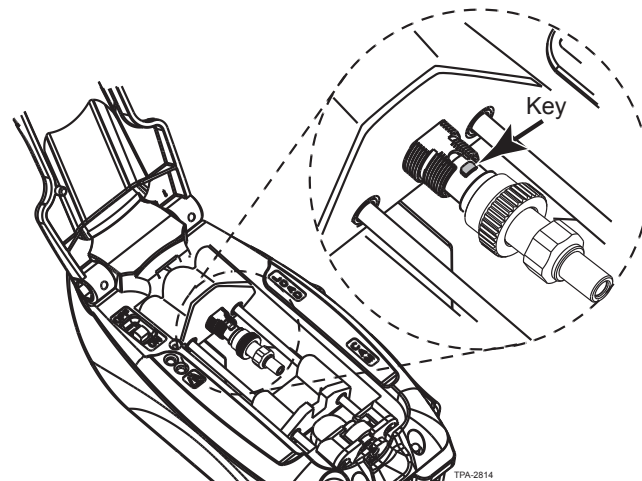

Replacement Parts for the Installation Tool

Use the part numbers below to order replacements.

- VFL Adapter and Cleaning Sticks:
1.25 mm adapter: p/n VFL-A125
2.5 mm adapter: p/n VFL-A250
To order both adapters: p/n VFL-AKIT
- 1.25 mm cleaning sticks: CLEAN-STICKS-125
- 2.5 mm cleaning sticks: CLEAN-STICKS-250

7.2. Maintaining the FBC-015 Cleaver

The FBC-015 Cleaver requires little maintenance; however, keeping the clamps and blade clean and periodically replacing the blade will ensure good cleaves.

7.2.1 Cleaning the Clamps

Step 1: Fold one of the provided Fiber Wipes in half.

Step 2: Press the button of the first clamp to be cleaned.

Step 3: Insert the wipe in the clamp and release the button.

Step 4: Gently pull the wipe out.

Step 5: Repeat for the second clamp.

Step 6: Dispose of the used wipe after use. Do not use wipe more than once.

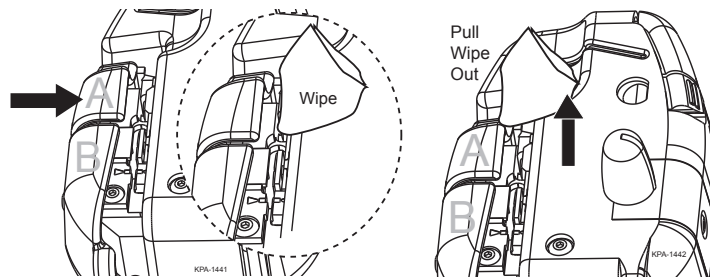

7.2.2 Changing the Blade Assembly

Replacement blades can be ordered from Corning Cable Systems.

- Blade Assembly: p/n FBC-14-15-16-BLADE.
- See Installation guide 006-374 that comes with the blade assembly to change the blade.

7.3. Connector Cleaning

Clean UniCam® connectors with Fiber Wipes and Fiber Optic Cleaning Fluid. Corning Cable Systems recommends using this cleaning procedure every time a connector is unmated or the connector is excessively dirty.

- Step 1:** Take a Fiber Wipe and fold once to make a square.
- Step 2:** Place the wipe on saturator top of the Fiber Optic Cleaning Fluid and press two to three times to wet the wipe.
- Step 3:** Wipe the connector end face with the wet wipe to remove dirt and debris. Wipe again with a dry wipe.
- Step 4:** If the connector is satisfactorily clean, immediately mate it in the appropriate adapter or sleeve, or replace the dust cap over the end face.



7.4. Troubleshooting

This section provides solutions to common problems. Consult the table below before sending the tool in for repair.

Problem	Possible Causes	Solutions (Actions)
Green Power Light flashes or does not come on.	Batteries need to be replaced.	Replace batteries following the instructions in the "Section 7.1.1 Changing the Batteries" on page 29
Connector will not load easily.	<ol style="list-style-type: none"> 1. Wrench is not in starting position. 2. Connector cam is not in open position. 	<ol style="list-style-type: none"> 1. Press Reset Button and try loading connector again. 2. Check to see that the connector cam is in the open position, page 9.
<p>Amber Error Light flashes</p> <p>NOTE: The cover must be open to complete each action. After each action, close the cover to see if Amber Error Light has cleared.</p>	<ol style="list-style-type: none"> 1. Ferrule Adapter is not fully seated on connector. 2. Connector loaded incorrectly. 3. Ferrule Adapter or connector may be dirty. 	<ol style="list-style-type: none"> 1. Ensure that the: <ul style="list-style-type: none"> • Proper Ferrule Adapter is installed in the tool. • Ferrule Adapter is fully seated on the UniCam® connector. • Clear ferrule dust cap is removed from the connector. 2. Ensure the connector is loaded into the tool correctly. <ul style="list-style-type: none"> • The date code on SC, the LC latch, or the "UP" on the ST® Compatible load adapter must be up. • The lead-in tube must protrude past the crimp arms with the flare visible beyond the crimp arms. • With no fiber inserted in the connector, press the CAM button and then press the Reset Button. 3. Clean the adapter and connector following the instructions in Sections 7.1.2 and 7.3, respectively.

Problem	Possible Causes	Solutions (Actions)
<p>Amber Error Light flashes (continued)</p> <p>NOTE: The cover must be open to complete each action. After each action, close the cover to see if Error Light has cleared.</p>	<ol style="list-style-type: none"> 4. Ferrule Adapter is not properly secured to the Ferrule Adapter Port. 5. The photo detector is dirty. 6. Weak batteries 	<ol style="list-style-type: none"> 4. Ensure the coupling nut on the Ferrule Adapter is tight. 5. Clean the photo detector using a dry wipe. 6. Replace the batteries in "Section 7.1.1 Changing the Batteries" on page 29.
<p>Cleaver is producing bad cleaves or breaking fibers.</p>	<ol style="list-style-type: none"> 1. Debris in the clamps 2. Blade is worn or damaged. 	<ol style="list-style-type: none"> 1. Clean the clamps per the instructions in "Section 7.2.1 Cleaning the Clamps" on page 32. 2. Replace the blade per the instructions in "Section 7.2.2 Changing the Blade Assembly" on page 32.
<p>Unable to achieve a successful termination. (Green termination light will not illuminate.)</p>	<ol style="list-style-type: none"> 1. Cover not closed 2. Error light not cleared 3. Fiber is not inserted correctly into the connector. 4. Improper fiber preparation 5. Bad cleave due to debris in the clamps. 	<ol style="list-style-type: none"> 1. Ensure that you have closed the cover before inserting the fiber. 2. See Problem "Amber Error Light Flashes" above. 3. While holding onto the fiber, press the Reset Button and try re-seating the fiber. 4. Ensure that the appropriate sections in Chapters 4 and 5 were followed. If unsure, press the Reset Button, remove the fiber, and start again at Chapter 4. 5. Refer to the "Cleaver is producing bad cleaves..." troubleshooting problem above.

Problem	Possible Causes	Solutions (Actions)
Unable to achieve a successful termination. (Green termination light will not illuminate.)	6. Broken fiber while inserting into connector. 7. Wrong fiber type 8. Damaged connector 9. Weak batteries 10. Out-dated connector.	6. While holding onto the fiber, press the Reset Button and remove fiber. Get a new connector and re-strip, re-cleave, and insert the fiber again. 7. Ensure that the connector and fiber type match. 8. While holding onto the fiber, press the Reset Button and remove fiber. Get a new connector, go back to Chapter 4, and start over, including re-cleaving the fiber. 9. Replace the batteries in "Section 7.1.1 Changing the Batteries" on page 29. 10. Make sure connector is manufactured after 12/2006.

If unable to successfully troubleshoot the installation tool using the table above, please call Corning Cable Systems Technical Support at 1-800-743-2671.

7.5. Testing UniCam® Connectors

If you have questions about proper testing and required equipment, etc., call Corning Cable Systems Technical Support at 1-800-743-2671.