

## Hexagon socket head cap screws (modified version of ISO 4762)

**DIN**  
**912**

Zylinderschrauben mit Innensechskant; ISO 4762 modifiziert

Supersedes September 1979 edition

As it is current practice in standards published by the International Organization for Standardization (ISO), the comma has been used throughout as a decimal marker.

This standard contains the main specifications of ISO 4762 - 1977, adopted in a modified form, with national addenda. These addenda are shaded grey in clauses 1 and 3 to 6.

Dimensions in mm

### 1 Field of application

This standard specifies product grade A hexagon socket head cap screws with metric screw threads and thread diameters from 1.4 to 100 mm<sup>1)</sup>. If, in exceptional cases, the screws are to meet requirements other than those given in this standard, these shall be selected in accordance with the appropriate standards.

### 2 Dimensions

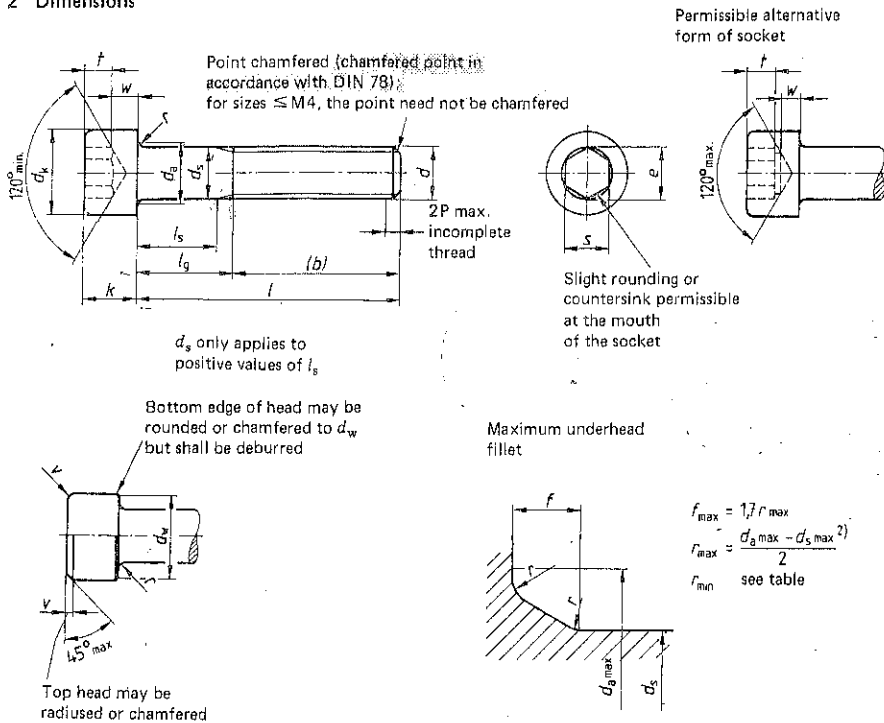

1) In ISO 4762, the range is M 1.5 to M 36.

2) In ISO 4762, this is given incorrectly as  $r_{max} = \frac{d_a - d_s}{2}$ ; an application has been made to ISO to correct this.

Continued on pages 2 to 12

Table 1.

Thread size <i>d</i>	M 1,4		M 1,6		M 2		M 2,5			
	Reference dimension		Reference dimension		Reference dimension		Reference dimension			
<i>P</i> 1)	0,3		0,35		0,4		0,45			
<i>b</i>	14		15		16		17			
<i>d<sub>k</sub></i>	max. 2)	2,6	3	3,8	4,5					
	max. 3)	2,74	3,14	3,98	4,68					
<i>d<sub>n</sub></i>	min.	2,46	2,86	3,62	4,32					
	max.	1,8	2	2,6	3,1					
<i>d<sub>s</sub></i>	max.	1,4	1,6	2	2,5					
	min.	1,26	1,46	1,86	2,36					
<i>e</i>	min. 4)		1,5		1,73		2,3			
<i>f</i>	max.		0,34		0,34		0,51			
<i>k</i>	max.	1,4	1,6	2	2,5					
	min.	1,26	1,46	1,86	2,36					
<i>r</i>	min.		0,1		0,1		0,1			
<i>s</i>	Nominal dimension		1,3		1,5		2			
	min.	1,32	1,52	1,52	2,02					
	max.	1,36	1,56	1,56	2,06					
<i>t</i>	min.		0,6		0,7		1			
<i>v</i>	max.		0,14		0,16		0,2			
<i>d<sub>w</sub></i>	min.		2,32		2,72		3,48			
<i>w</i>	min.		0,5		0,55		0,55			
<i>l</i>			Shank lengths <i>l<sub>s</sub></i> and <i>l<sub>g</sub></i>							
Nominal length	min.	max.	<i>l<sub>s</sub></i> min.	<i>l<sub>g</sub></i> max.	<i>l<sub>s</sub></i> min.	<i>l<sub>g</sub></i> max.	<i>l<sub>s</sub></i> min.	<i>l<sub>g</sub></i> max.	<i>l<sub>s</sub></i> min.	<i>l<sub>g</sub></i> max.
2	1,8	2,2	—	0,9	—	—	—	—	—	—
2,5	2,3	2,7	—	0,9	—	1,05	—	—	—	—
3	2,8	3,2	—	0,9	—	1,05	—	1,2	—	—
4	3,76	4,24	—	0,9	—	1,05	—	1,2	—	1,35
5	4,76	5,24	—	0,9	—	1,05	—	1,2	—	1,35
6	5,76	6,24	—	0,9	—	1,05	—	1,2	—	1,35
8	7,71	8,29	—	0,9	—	1,05	—	1,2	—	1,35
10	9,71	10,29	—	0,9	—	1,05	—	1,2	—	1,35
12	11,65	12,35	—	0,9	—	1,05	—	1,2	—	1,35
16	15,65	16,35	—	—	—	1,05	—	1,2	—	1,35
20	19,58	20,42	—	—	—	—	—	1,2	—	1,35
25	24,58	25,42	—	—	—	—	—	—	—	1,35
30	29,58	30,42	—	—	—	—	—	—	—	—
35	34,5	35,5	—	—	—	—	—	—	—	—
40	39,5	40,5	—	—	—	—	—	—	—	—
45	44,5	45,5	—	—	—	—	—	—	—	—
50	49,5	50,5	—	—	—	—	—	—	—	—
55	54,4	55,6	—	—	—	—	—	—	—	—
60	59,4	60,6	—	—	—	—	—	—	—	—
65	64,4	65,6	—	—	—	—	—	—	—	—
70	69,4	70,6	—	—	—	—	—	—	—	—
80	79,4	80,6	—	—	—	—	—	—	—	—

1) *P* = Thread pitch of coarse thread in accordance with DIN 13 Part 12.  
 2) For plain heads.  
 3) For knurled heads and for heads with designation on circumference.  
 4) *e* min. = 1,14 · *s* min.

3 Material  
 St = 9 SMn  
 UOST  
 A1 = Stain.  
 Al-Leg = A  
 CuZn = Co.  
 PA = Polya.  
 Other mate

4 Finish  
 Product clas  
 Surface peal  
 General tole

3) These mate  
 previous ec

Table 1. (Continued)

Thread size <i>d</i>		M 3	M 4	M 5	M 6	M 8
<i>P</i> 1)		—	—	—	—	M B X 1.
<i>h</i>	Reference dimension	0,5	0,7	0,8	1	1,25
<i>d<sub>h</sub></i>	max. 2)	18	20	22	24	28
	max. 3)	5,5	7	8,5	10,22	13
	min.	5,88	7,22	8,72	9,78	12,73
<i>d<sub>a</sub></i>	max.	5,32	6,78	8,28	9,78	12,73
	min.	3,6	4,7	5,7	6,8	9,2
<i>d<sub>s</sub></i>	max.	3	4	5	6	8
	min.	2,86	3,82	4,82	5,82	7,78
<i>e</i>	min. 4)	2,87	3,44	4,58	5,72	6,86
<i>f</i>	max.	0,51	0,6	0,6	0,68	1,02
<i>k</i>	max.	3	4	5	6	8
	min.	2,86	3,82	4,82	5,7	7,64
<i>r</i>	min.	0,1	0,2	0,2	0,25	0,4
<i>s</i>	Nominal dimension	2,5	3	4,02	5,02	6,02
	min.	2,52	3,02	4,095	5,14	6,14
	max.	2,58	3,08	4,095	3	4
<i>t</i>	min.	1,3	2	2,5	3	4
<i>v</i>	max.	0,3	0,4	0,5	0,6	0,8
<i>d<sub>w</sub></i>	min.	5,07	6,53	8,03	9,38	12,33
<i>w</i>	min.	1,15	1,4	1,9	2,3	3

Nominal length	Shank lengths <i>l<sub>s</sub></i> and <i>l<sub>g</sub></i>											
	<i>l<sub>s</sub></i>		<i>l<sub>g</sub></i>		<i>l<sub>s</sub></i>		<i>l<sub>g</sub></i>		<i>l<sub>s</sub></i>		<i>l<sub>g</sub></i>	
	min.	max.	min.	max.	min.	max.	min.	max.	min.	max.	min.	max.
2	1,8	2,2										
2,5	2,3	2,7										
3	2,8	3,2										
4	3,76	4,24										
5	4,76	5,24	—	1,5								
6	5,76	6,24	—	1,5	—	2,1			2,4			
8	7,71	8,29	—	1,5	—	2,1	—		2,4	—	3	
10	9,71	10,29	—	1,5	—	2,1	—		2,4	—	3	—
12	11,65	12,35	—	1,5	—	2,1	—		2,4	—	3	—
16	15,65	16,35	—	1,5	—	2,1	—		2,4	—	3	—
20	19,58	20,42	—	1,5	—	2,1	—		2,4	—	3	—
25	24,58	25,42	4,5	7	—	2,1	—		2,4	—	3	—
30	29,58	30,42	9,5	12	—	2,1	—		2,4	—	3	—
35	34,5	35,5			6,5	10	4	8				
40	39,5	40,5			11,5	15	9	13	6	11		
45	44,5	45,5			16,5	20	14	18	11	16	5,75	12
50	49,5	50,5					19	23	16	21	10,75	17
55	54,4	55,6					24	28	21	26	15,75	22
60	59,4	60,6							26	31	20,75	27
65	64,4	65,6							31	36	25,75	32
70	69,4	70,6									30,75	37
80	79,4	80,6									35,75	42
											45,75	52

For 1) to 4) see page 2.

Table 1. (Continued)

M  
sc  
  
M  
M 1  
M 1  
  
M 1  
M 1  
  
M 11  
M 20  
  
M 22  
M 24  
  
M 26  
  
M 30  
  
M 38  
M 38  
  
M 42 X  
M 45 X  
  
M 48 X  
M 52 X  
  
1) e min.  
2) The head  
  
3 Mat:  
St = 9 St  
UCS  
Al = Sta  
Al-Leg =  
CuZn = C  
PA = Pol  
Other ma  
  
4 Finis  
Product c  
Surface p  
General to

Thread size <i>d</i>	M 10		M 12		(M 14)	M 16		(M 18)				
	M 10 × 1,25		M 12 × 1,25		(M 14 × 1,5)	M 16 × 1,5		(M 18 × 1,5)				
	M 10 × 1		M 12 × 1,5		—	—		(M 18 × 2)				
<i>p</i> 1)	1,5		1,75		2	2		2,5				
<i>b</i> Reference dimension	32		36		40	44		48				
<i>d<sub>k</sub></i>	max. 2)	16		18		21	24		27			
	max. 3)	16,27		18,27		21,33	24,33		27,33			
	min.	15,73		17,73		20,67	23,67		26,67			
<i>d<sub>a</sub></i>	max.	11,2		13,7		15,7	17,7		20,2			
	max.	10		12		14	16		18			
<i>d<sub>s</sub></i>	min.		9,78		11,73		13,73		15,73			
<i>e</i>	min. 4)		9,15		11,43		13,72		16			
<i>f</i>	max.		1,02		1,87		1,87		1,87			
<i>h</i>	max.	10		12		14	16		18			
	min.	9,64		11,57		13,57	15,57		17,57			
<i>r</i>	min.		0,4		0,6		0,6		0,6			
<i>s</i>	Nominal dimension		8		10		12		14			
	min.		8,025		10,025		12,032		14,032			
	max.		8,175		10,175		12,212		14,212			
<i>t</i>	min.		5		6		7		8			
<i>v</i>	max.		1		1,2		1,4		1,6			
<i>d<sub>w</sub></i>	min.		15,33		17,23		20,17		23,17			
<i>w</i>	min.		4		4,8		5,8		6,8			
Shank lengths <i>l<sub>s</sub></i> and <i>l<sub>g</sub></i>												
Nominal length	<i>l</i>		<i>l<sub>s</sub></i>		<i>l<sub>g</sub></i>		<i>l<sub>s</sub></i>		<i>l<sub>g</sub></i>		<i>l<sub>s</sub></i>	
	min.	max.	min.	max.	min.	max.	min.	max.	min.	max.	min.	max.
16	15,65	16,35	—	4,5	—	—	—	—	—	—	—	—
20	19,58	20,42	—	4,5	—	5,25	—	—	—	—	—	—
25	24,58	25,42	—	4,5	—	5,25	—	6	—	6	—	—
30	29,58	30,42	—	4,5	—	5,25	—	6	—	6	—	7,5
35	34,5	35,5	—	4,5	—	5,25	—	6	—	6	—	7,5
40	39,5	40,5	—	4,5	—	5,25	—	6	—	6	—	7,5
45	44,5	45,5	5,5	13	—	5,25	—	6	—	6	—	7,5
50	49,5	50,5	10,5	18	—	5,25	—	6	—	6	—	7,5
55	54,4	55,6	15,5	23	10,25	19	—	6	—	6	—	7,5
60	59,4	60,6	20,5	28	15,25	24	10	20	—	6	—	7,5
65	64,4	65,6	25,5	33	20,25	29	15	25	11	21	—	7,5
70	69,4	70,6	30,5	38	25,25	34	20	30	16	26	9,5	22
80	79,4	80,6	40,5	48	35,25	44	30	40	26	36	19,5	32
90	89,3	90,7	50,5	58	45,25	54	40	50	36	46	29,5	42
100	99,3	100,7	60,5	68	55,25	64	50	60	46	56	39,5	52
110	109,3	110,7	—	—	65,25	74	60	70	56	66	49,5	62
120	119,3	120,7	—	—	75,25	84	70	80	66	76	59,5	72
130	129,2	130,8	—	—	—	—	80	90	76	86	69,5	82
140	139,2	140,8	—	—	—	—	90	100	86	96	79,5	92
150	149,2	150,8	—	—	—	—	—	—	96	106	89,5	102
160	159,2	160,8	—	—	—	—	—	—	106	116	99,5	112
180	179,2	180,8	—	—	—	—	—	—	—	—	119,5	132
200	199,1	200,9	—	—	—	—	—	—	—	—	—	—

For 1) to 4) see page 2.

3) These m previous

Table 1. (Continued)

Thread size <i>d</i>	M 20		(M 22)		M 24		(M 27)		M 30					
	M 20 X 1,5		(M 22 X 1,5)		M 24 X 2		(M 27 X 2)		M 30 X 2					
	M 20 X 2		(M 22 X 2)		—		—		—					
<i>P</i> 1)	2,5		2,5		3		66		72					
<i>b</i> Reference dimension	52		56		60		40		45					
<i>d<sub>k</sub></i> max. 2)	30		33		36		40,39		45,39					
<i>d<sub>k</sub></i> max. 3)	30,33		33,39		36,39		40,39		45,39					
<i>d<sub>k</sub></i> min.	29,67		32,61		35,61		39,61		44,61					
<i>d<sub>a</sub></i> max.	22,4		24,4		26,4		30,4		33,4					
<i>d<sub>s</sub></i> max.	20		22		24		27		30					
<i>d<sub>s</sub></i> min.	19,67		21,67		23,67		26,67		29,67					
<i>e</i> min. 4)	19,44		19,44		21,73		21,73		25,15					
<i>f</i> max.	2,04		2,04		2,04		2,89		2,89					
<i>k</i> max.	20		22		24		27		20					
<i>k</i> min.	19,48		21,48		23,48		26,48		29,48					
<i>r</i> min.	0,8		0,8		0,8		1		1					
<i>s</i> Nominal dimension	17		17		19		19		22					
<i>s</i> min.	17,05		17,05		19,065		19,065		22,065					
<i>s</i> max.	17,23		17,23		19,275		19,275		22,275					
<i>t</i> min.	10		11		12		13,5		15,5					
<i>v</i> max.	2		2,2		2,4		2,7		3					
<i>d<sub>w</sub></i> min.	28,87		31,81		34,81		38,61		43,61					
<i>w</i> min.	8,6		9,4		10,4		11,9		13,1					
Shank lengths <i>l<sub>s</sub></i> and <i>l<sub>g</sub></i>														
Nominal length	<i>l</i>		<i>l<sub>s</sub></i>		<i>l<sub>g</sub></i>		<i>l<sub>s</sub></i>		<i>l<sub>g</sub></i>		<i>l<sub>s</sub></i>		<i>l<sub>g</sub></i>	
	min.	max.	min.	max.	min.	max.	min.	max.	min.	max.	min.	max.	min.	max.
16	15,65	16,35												
20	19,58	20,42												
25	24,58	25,42												
30	29,58	30,42	—	7,5	—	7,5	—	7,5	—	7,5	—	7,5	—	7,5
35	34,5	35,5	—	7,5	—	7,5	—	7,5	—	7,5	—	7,5	—	7,5
40	39,5	40,5	—	7,5	—	7,5	—	7,5	—	7,5	—	7,5	—	7,5
45	44,5	45,5	—	7,5	—	7,5	—	7,5	—	7,5	—	7,5	—	7,5
50	49,5	50,5	—	7,5	—	7,5	—	7,5	—	7,5	—	7,5	—	7,5
55	54,4	55,6	—	7,5	—	7,5	—	7,5	—	7,5	—	7,5	—	7,5
60	59,4	60,6	—	7,5	—	7,5	—	7,5	—	7,5	—	7,5	—	7,5
65	64,4	65,6	—	7,5	—	7,5	—	7,5	—	7,5	—	7,5	—	7,5
70	69,4	70,6	—	7,5	—	7,5	—	7,5	—	7,5	—	7,5	—	7,5
80	79,4	80,6	15,5	28	11,5	24	—	9	—	9	—	9	—	10,5
90	89,3	90,7	25,5	38	21,5	34	15	30	—	9	—	9	—	10,5
100	99,3	100,7	35,5	48	31,5	44	25	40	19	34	—	9	—	10,5
110	109,3	110,7	45,5	58	41,5	54	35	50	29	44	20,5	38	—	10,5
120	119,3	120,7	55,5	68	51,5	64	45	60	39	54	30,5	48	—	10,5
130	129,2	130,8	65,5	78	61,5	74	55	70	49	64	40,5	58	—	10,5
140	139,2	140,8	75,5	88	71,5	84	65	80	59	74	50,5	68	—	10,5
150	149,2	150,8	85,5	98	81,5	94	75	90	69	84	60,5	78	—	10,5
160	159,2	160,8	95,5	108	91,5	104	85	100	79	94	70,5	88	—	10,5
180	179,2	180,8	115,5	128	111,5	124	105	120	99	114	90,5	108	—	10,5
200	199,1	200,9	135,5	148	131,5	144	125	140	119	134	110,5	128	—	10,5

For 1) to 4) see page 2.

Table 1. (Continued)

Thread size <i>d</i>	(M 33)		M 36		M 42		M 48		M 56					
	(M 33 X 2)		M 36 X 3		M 42 X 3		M 48 X 3		M 56 X 4					
<i>P</i> <sup>1)</sup>	3,5		4		4,5		5		6,5					
<i>b</i>	Reference dimension		78		84		96		108					
<i>d<sub>k</sub></i>	max. 2)	50	54	63	72	84,54	84,54	84,54	84,54	84,54				
	max. 3)	50,39	54,46	63,46	72,46	84,54	84,54	84,54	84,54	84,54				
	min.	49,61	53,54	62,54	71,54	83,46	83,46	83,46	83,46	83,46				
<i>d<sub>a</sub></i>	max.	36,4	39,4	45,5	52,6	63	63	63	63	63				
	max.	33	36	42	48	56	56	56	56	56				
<i>d<sub>s</sub></i>	max.	32,61	35,61	41,61	47,61	55,54	55,54	55,54	55,54	55,54				
	min.	27,43	30,85	36,57	41,13	46,83	46,83	46,83	46,83	46,83				
<i>e</i>	min. 4)	2,89	2,89	3,06	3,91	5,95	5,95	5,95	5,95	5,95				
<i>f</i>	max.	2,89	2,89	3,06	3,91	5,95	5,95	5,95	5,95	5,95				
	max.	33	36	42	48	56	56	56	56	56				
<i>h</i>	max.	32,38	35,38	41,38	47,38	56,26	56,26	56,26	56,26	56,26				
	min.	32,38	35,38	41,38	47,38	56,26	56,26	56,26	56,26	56,26				
<i>r</i>	min.	1	1	1,2	1,6	2	2	2	2	2				
	min.	1	1	1,2	1,6	2	2	2	2	2				
<i>s</i>	Nominal dimension	24	27	32,08	36,08	41,08	41,08	41,08	41,08	41,08				
	min.	24,065	27,065	32,08	36,08	41,08	41,08	41,08	41,08	41,08				
	max.	24,275	27,275	32,33	36,33	41,33	41,33	41,33	41,33	41,33				
<i>t</i>	min.	18	19	24	28	34	34	34	34	34				
	min.	18	19	24	28	34	34	34	34	34				
<i>v</i>	max.	3,3	3,6	4,2	4,8	5,5	5,5	5,5	5,5	5,5				
	max.	3,3	3,6	4,2	4,8	5,5	5,5	5,5	5,5	5,5				
<i>d<sub>w</sub></i>	min.	48,61	52,54	61,34	70,34	82,26	82,26	82,26	82,26	82,26				
	min.	48,61	52,54	61,34	70,34	82,26	82,26	82,26	82,26	82,26				
<i>w</i>	min.	13,5	15,3	16,3	17,5	19	19	19	19	19				
	min.	13,5	15,3	16,3	17,5	19	19	19	19	19				
Shank lengths <i>l<sub>s</sub></i> and <i>l<sub>g</sub></i>														
Nominal length	<i>l</i>		<i>l<sub>s</sub></i>		<i>l<sub>g</sub></i>		<i>l<sub>s</sub></i>		<i>l<sub>g</sub></i>		<i>l<sub>s</sub></i>		<i>l<sub>g</sub></i>	
	min.	max.	min.	max.	min.	max.	min.	max.	min.	max.	min.	max.	min.	max.
50	49,5	50,5	—	10,5	—	—	—	—	—	—	—	—	—	—
55	54,4	55,6	—	10,5	—	12	—	—	—	—	—	—	—	—
60	59,4	60,6	—	10,5	—	12	—	—	13,5	—	—	—	—	—
65	64,4	65,6	—	10,5	—	12	—	—	13,5	—	—	—	—	—
70	69,4	70,6	—	10,5	—	12	—	—	13,5	—	15	—	—	16,5
80	79,4	80,6	—	10,5	—	12	—	—	13,5	—	15	—	—	16,5
90	89,3	90,7	—	10,5	—	12	—	—	13,5	—	15	—	—	16,5
100	99,3	100,7	—	10,5	—	12	—	—	13,5	—	15	—	—	16,5
110	109,3	110,7	14,5	32	—	12	—	—	13,5	—	15	—	—	16,5
120	119,3	120,7	24,5	42	16	36	—	—	13,5	—	15	—	—	16,5
130	129,2	130,8	34,5	52	26	46	—	—	13,5	—	15	—	—	16,5
140	139,2	140,8	44,5	62	36	56	21,5	44	—	—	15	—	—	16,5
150	149,2	150,8	54,5	72	46	66	31,5	54	—	—	15	—	—	16,5
160	159,2	160,8	64,5	82	56	76	41,5	64	27	52	—	—	—	16,5
180	179,2	180,8	84,5	102	76	96	61,5	84	47	72	56	56	—	—
200	199,1	200,9	104,5	122	96	116	81,5	104	67	92	48,5	48,5	—	—
220	219,1	220,9	124,5	142	116	136	101,5	124	87	112	68,5	68,5	—	—
240	239,1	240,9	144,5	162	136	156	121,5	144	107	132	88,5	88,5	—	—
260	258,95	261,05	164,5	182	156	176	141,5	164	127	152	108,5	108,5	—	—
280	278,95	281,05	184,5	202	176	196	161,5	184	147	172	128,5	128,5	—	—
300	298,95	301,05	204,5	222	196	216	181,5	204	167	192	148,5	148,5	—	—

For 1) to 4) see page 2.

3) These previc

Table 1. (Continued)

Thread size <i>d</i>	M 64		M 72 × 6		M 80 × 6		M 90 × 6		M 100 × 6			
	M 64 × 4		M 72 × 4		M 80 × 4		M 90 × 4		M 100 × 4			
<i>P</i> 1)	6		6		6		6		6			
<i>b</i> Reference dimension	140		156		172		192		212			
<i>d<sub>k</sub></i> max. 2)	96		108		120		135		150			
<i>d<sub>k</sub></i> max. 3)	96,54		108,54		120,54		135,63		150,63			
<i>d<sub>k</sub></i> min.	95,46		107,46		119,46		134,37		149,37			
<i>d<sub>a</sub></i> max.	71		79		87		97		107			
<i>d<sub>s</sub></i> max.	64		72		80		90		100			
<i>d<sub>s</sub></i> min.	63,54		71,54		79,54		89,46		99,46			
<i>e</i> min. 4)	52,63		62,81		74,21		85,61		97,04			
<i>f</i> max.	5,95		5,95		5,95		5,95		5,95			
<i>h</i> max.	64		72		80		90		100			
<i>h</i> min.	63,26		71,26		79,26		89,13		99,13			
<i>r</i> min.	2		2		2		2,5		2,5			
<i>s</i> Nominal dimension	46		55		65		75		85			
<i>s</i> min.	46,08		55,10		65,10		75,10		85,12			
<i>s</i> max.	46,33		55,40		65,40		75,40		85,47			
<i>l</i> min.	38		43		48		54		60			
<i>v</i> max.	6,4		7,2		8		9		10			
<i>d<sub>w</sub></i> min.	94,26		106,26		118,16		133,17		148,17			
<i>w</i> min.	22		25		27		32		34			
Shank lengths <i>l<sub>s</sub></i> and <i>l<sub>g</sub></i>												
Nominal length	<i>l</i>		<i>l<sub>s</sub></i>	<i>l<sub>g</sub></i>	<i>l<sub>s</sub></i>	<i>l<sub>g</sub></i>	<i>l<sub>s</sub></i>	<i>l<sub>g</sub></i>	<i>l<sub>s</sub></i>	<i>l<sub>g</sub></i>	<i>l<sub>s</sub></i>	<i>l<sub>g</sub></i>
	min.	max.	min.	max.	min.	max.	min.	max.	min.	max.	min.	max.
50	49,5	50,5										
55	54,4	55,6										
60	59,4	60,6										
65	64,4	65,6										
70	69,4	70,6										
80	79,4	80,6										
90	89,3	90,7	—	18								
100	99,3	100,7	—	18	—	18						
110	109,3	110,7	—	18	—	18						
120	119,3	120,7	—	18	—	18	—	18				
130	129,2	130,8	—	18	—	18	—	18	—	18		
140	139,2	140,8	—	18	—	18	—	18	—	18	—	18
150	149,2	150,8	—	18	—	18	—	18	—	18	—	18
160	159,2	160,8	—	18	—	18	—	18	—	18	—	18
180	179,2	180,8	—	18	—	18	—	18	—	18	—	18
200	199,1	200,9	30	60	—	18	—	18	—	18	—	18
220	219,1	220,9	50	80	34	64	—	18	—	18	—	18
240	239,1	240,9	70	100	54	84	38	68	—	18	—	18
260	258,95	261,05	90	120	74	104	58	88	38	68	—	18
280	278,95	281,05	110	140	94	124	78	108	58	88	38	68
300	298,95	301,05	130	160	114	144	98	128	78	108	58	88

For 1) to 4) see page 2.

The commercial nominal lengths are designated by giving the shank lengths *l<sub>s</sub>* and/or *l<sub>g</sub>*. Thread sizes and intermediate lengths given in brackets shall be avoided where possible.

Nominal lengths above 300 mm shall be in 20 mm steps.

Screws with nominal length above the dashed stepped line are threaded to head (distance between the last full thread and the head bearing surface *l<sub>g</sub>* max. = 3 *P*). Screws with nominal lengths below the dashed stepped line have *l<sub>g</sub>* and *l<sub>s</sub>* values in accordance with the following formulae: *l<sub>g</sub>* max. = *l* (nominal length) - *b* (reference dimension); *l<sub>s</sub>* min. = *l<sub>g</sub>* max. - 5 *P*.

The values given for *l<sub>s</sub>* and *l<sub>g</sub>* apply to screws with coarse threads.

3 Technical delivery conditions

Material		Steel	Stainless steel	Non-ferrous metal
General requirements		In accordance with DIN 267 Part 1 <sup>1)</sup>		
Thread	Tolerance	5g6g for property class 12.9; 6g <sup>1)</sup> for other property classes.		
	Standard	ISO 261, ISO 965	DIN 13 Part 12 and Part 15	
Mechanical properties	Property class (material)	≤ M39 <sup>2)</sup> : 8.8; 10.9; 12.9 > M39: as agreed	≤ M20: A2-70; A4-70 > M20 ≤ M39: A2-50 <sup>3)</sup> A4-50	.....
	Standard	DIN ISO 898 Part 1	ISO 3506 <sup>4)</sup> DIN 267 Part 11 <sup>4)</sup>	DIN 267 Part 18 <sup>5)</sup>
Tolerances on dimensions and form	Product grade	A		
	Standard	ISO 4759/1/DIN ISO 4759 Part 1		
Surface	Product grade	Black oxide (thermal or chemical)	Bright	Bright
	Standard	DIN 267 Part 2 (at present at the stage of draft) shall apply with regard to the peak-to-valley heights of the surface. DIN 267 Part 19 shall apply with regard to the permissible surface defects. DIN 267 Part 9 shall apply with regard to electroplating. If different electroplating or other surface protection is desired, this shall be agreed upon at the time of ordering.		
Acceptance testing		DIN 267 Part 5 shall apply with regard to acceptance testing.		

1) Only for screws without surface protection. 6g makes it possible for normal coating thicknesses to be applied in accordance with DIN 267 Part 9 but the reference line shall not be exceeded. Depending on the coating thickness required, a larger fundamental deviation shall be selected than that for the g position. A larger fundamental deviation may impair the stripping strength of the screw/nut connection.  
 2) In ISO 4762, only up to M36 or below.  
 3) In ISO 4742 A2-80 is not correct, and an application has been made to ISO for a correction.  
 4) The content of ISO 3506 is covered by DIN 267 Part 11. It was still being prepared when ISO 4762 - 1977 was published.  
 5) A selection of materials from DIN 267 Part 18 will be specified later for hexagon socket head cap screws.

4 Designation

Designation of a hexagon socket head cap screw with M 12 screw thread, nominal length  $l = 60$  mm and assigned to property class 12.9: Hexagon socket head cap screw DIN 912 - M 12 x 60 - 12.9

DIN 982 shall apply with regard to the designation of types and designs with additional data to be given when ordering, e.g. type B with shank diameter = pitch diameter.

DIN 6900 shall apply with regard to the designation of designs with captive components (screw assemblies).

DIN 7500 applies with regard to the designation of designs with thread-forming properties.

The international designation for hexagon socket head cap screws in accordance with ISO 4762 (not the shaded data) is, e.g.: Hexagon socket head cap screw ISO 4762 - M 12 x 60 - 12.9

At present, the ISO 4762 designation does not include an acceptance test in accordance with DIN 267 Part 5. DIN 4000 - 2 - 1 tabular layout of article characteristics shall apply to screws in accordance with this standard.

I S I P T T T S.

Tz

If det If be

In pit

M  
M  
M  
M

1)  
2)

3  
St =

A1 =  
Al-L  
CuZn  
PA =  
Other

4 F  
Produ  
Surfat  
Gener

3) The prev



5 Mass

The values of mass given are guidance values and are given for the commercial lengths.

Table 2.

Thread size <i>d</i>	M 1,4	M 1,6	M 2	M 2,5	M 3	M 4	M 5	M 6	M 8	M 10	M 12	(M 14)	M 16	(M 18)	M 20	
Nominal length <i>l</i>	Mass (7,85 kg/dm <sup>3</sup> ) kg per 1000 units ≈															
2	0,065															
2,5	0,060	0,085														
3	0,065	0,090	0,155													
4	0,075	0,100	0,175	0,345												
5	0,085	0,110	0,195	0,375	0,67											
6	0,095	0,120	0,215	0,405	0,71	1,50										
9	0,115	0,140	0,255	0,465	0,80	1,65	2,45									
10	0,135	0,160	0,295	0,525	0,88	1,80	2,70	4,70								
12	0,155	0,180	0,355	0,585	0,96	1,95	2,95	5,07	10,9							
16		0,220	0,415	0,705	1,16	2,25	3,45	5,75	12,1	20,9						
20			0,495	0,825	1,36	2,65	4,01	6,53	13,4	22,9	32,1					
25				0,975	1,61	3,15	4,78	7,59	15,0	25,4	35,7	48,0	71,3			
30					1,86	3,65	5,55	8,30	16,9	27,9	39,3	53,0	77,8	111	128	
35						4,15	6,32	9,91	18,9	30,4	42,9	58,0	84,4	120	139	
40						4,65	7,09	11,0	20,9	32,9	46,5	63,0	91,0	129	150	
45							7,86	12,1	22,9	36,1	50,1	68,0	97,6	138	161	
50							8,63	13,2	24,9	39,3	54,5	73,0	106	147	172	
55								14,3	26,9	42,5	58,9	78,0	114	156	183	
60								15,4	28,9	45,7	63,4	84,0	122	165	194	
65									31,0	48,9	67,8	90,0	130	174	205	
70									33,0	52,1	71,3	96,0	138	183	216	
80									37,0	58,6	80,2	108	154	203	241	
90										64,9	89,1	120	170	223	266	
100										71,2	98,0	132	186	243	291	
110											107	144	202	263	316	
120											116	156	218	283	341	
130												168	234	303	366	
140												180	250	323	391	
150													266	343	416	
160														282	363	441
180															403	491
200																541

For hexagon socket head cap screws with fine threads, approximately the same masses may be assumed.



DIN 78	Thread ends, lengths of projection of thread ends for ISO metric screw threads as defined in DIN 13
DIN 267 Part 1	Fasteners; technical delivery conditions; general requirements
DIN 267 Part 2	(at present at the stage of draft) Fasteners; technical delivery conditions, types of finishes and dimensional accuracy
DIN 267 Part 5	Fasteners; technical delivery conditions, acceptance testing
DIN 267 Part 9	Fasteners; technical delivery conditions, components with electroplated coatings
DIN 267 Part 11	Fasteners; technical delivery conditions with supplements to ISO 3506, components made of stainless steel and acid-resistant steels
DIN 267 Part 18	Fasteners; technical delivery conditions, components made of non-ferrous metals
DIN 267 Part 19	Fasteners; technical delivery conditions, surface defects on bolts and screws
DIN 962	Screws, bolts, studs and nuts; designations, types and finishes
DIN 4000 Part 2	Tabular layouts of article characteristics for bolts, studs and nuts
DIN 6900	Screw assemblies
DIN 7500	Thread-forming screws for ISO metric screw threads
DIN ISO 898 Part 1	Mechanical properties of fasteners; bolts, screws and studs
DIN ISO 4759 Part 1	Tolerances for fasteners; bolts, screws and nuts with thread diameters $\geq 1,6$ and $\leq 150$ mm and product grades A, B and C

#### Previous editions

DIN 912 Part 1: 11.70; DIN 912 Part 2: 10.69; DIN 912: 10.33, 02.37, 04.46, 07.53, 03.61, 12.67, 09.79

#### Amendments

Compared with the September 1979 edition, the following amendments have been made:

- a) The content of the standard has been revised editorially.
- b) The designation in accordance with ISO 4762 has been included.
- c) The values for  $d_a$  have been changed for sizes M 12, M 14 and M 16.
- d) The masses for sizes M 56 to M 100  $\times$  6 have been corrected.
- e) The M 18  $\times$  2, M 20  $\times$  2 and M 22  $\times$  2 fine threads have been included.
- f) The reference to the permissible product grade F for sizes up to M 2,5 has been deleted.
- g) For general requirements, reference has been made to DIN 267 Part 1 and for permissible surface defects to DIN 267 Part 19.
- h) The position of the dashed stepped line for M 12, M 16, M 18, M 20, M 30, M 36, M 42, M 48 and M 56 has been changed.

#### Explanatory notes

As can be seen from the amendment section, no major or misleading amendments have been made to this revised edition of DIN 912 compared with the previous September 1979 edition. A few important points which have resulted from adopting ISO 4762 in modified form are explained below to help understand the standard:

- a) It was not possible to adopt ISO 4762 — 1977 as national Standard DIN ISO 4762 and as a replacement for the November 1970 edition of DIN 912 Part 1 and the October 1969 edition of Part 2 in unmodified form, as ISO 4762 only covers parts of the scope of these standards (M 1,6 to M 36) and does not specify any intermediate sizes. Also, ISO 4762 does not contain some international reference standards which, until they appear, have to be replaced by national standards, e.g. DIN 267 Part 5 for the acceptance test.
- b) In order to include ISO 4762 in modified form in DIN 912, the so-called shading solution, which in the meantime has also been used for other standards on fasteners, has been adopted, i.e. all the national specifications deviating from or extending beyond ISO 4762 — 1977 have been indicated by shading. Nothing has been deleted from ISO 4762.
- c) Translator's note. Paragraph c) is only of relevance to the German original and has thus been omitted from this translation.
- d) In the 1979 edition of DIN 912, some of the previous thread lengths were increased to comply with ISO 4762. After this edition was published, difficulties of conversion resulted in some cases which have, however, been resolved in the meantime. As is well known,  $b = 2d + 12$  mm applies uniformly for calculating the thread lengths.

